

# MANIACCESS ■ 170 AETJ L

Self-propelled electric articulating boom lift

- Working height : 16.90 m
- Max. outreach : 9.40 m
- Up and over : 7.00 m
- Overall width : 1.75 m





## 170 AETJ L

**↑** Working height .....16.90 m  
 Platform height .....14.90 m  
 Horizontal outreach .....9.40 m  
 Up and over clearance .....7.00 m  
 Jib movement.....+70° / -70°  
 Basket rotation.....140°  
 Turret rotation .....355°

**Platform capacity**.....200 kg/2 peoples  
**External use**.....45 km/h  
 (Maximum allowed wind speed)  
**Basket size**.....1.20 x 0.96 m

**① Width** .....1.75 m  
**② Length**.....6.84 m  
**③ Stowed length** (storage).....5.12 m  
**④ Height** .....1.97 m  
**⑤ Stowed height** (storage).....2.04 m

**⑥ Turning radius inside** .....1.97 m  
**⑦ Turning radius outside** .....4.30 m  
**⑧ Turning radius outside** (basket).....5.60 m  
**⑨ Ground clearance** .....0.14 m  
**⑩ Wheel base** .....2.00 m  
 Drive speed .....5.0 km/h  
 Working speed .....0.6 km/h

**Gradeability** .....22%  
**Maximum slope accepted** .....5% or 3°

**Weight**.....6 910 kg

**Tires**.....0.60 x 0.19 m  
**Wheel steer**.....2 (front)  
**Wheel drive**.....2 (back)

**Batteries** .....300 Ah / 2x24 V  
**Battery charger**.....45 Ah/48 V

### Standard equipment

- Protected control basket panel
- Electrical battery traction
- Negative brakes
- Lifting brackets
- Hour meter
- Warning buzzer in the basket
- 220 V predisposal
- Voltage indicator
- Safety manual pump
- Basket with mesh floor
- Bus CAN technology
- Diagnostic help integrated
- Dual electrical motors
- Rubber tires
- Integrated charger

### Options

- No marking tires
- High capacity battery (360 Ah)
- Dual voltage charger 110 V / 230 V
- Working lights
- Electric plug in the platform with circuit breaker (230 V)
- Flashing light
- Drive alarm
- All motion alarm
- Cold conditions -25°C
- Air predisposal
- Water predisposal
- Specific painting
- Biodegradable oil

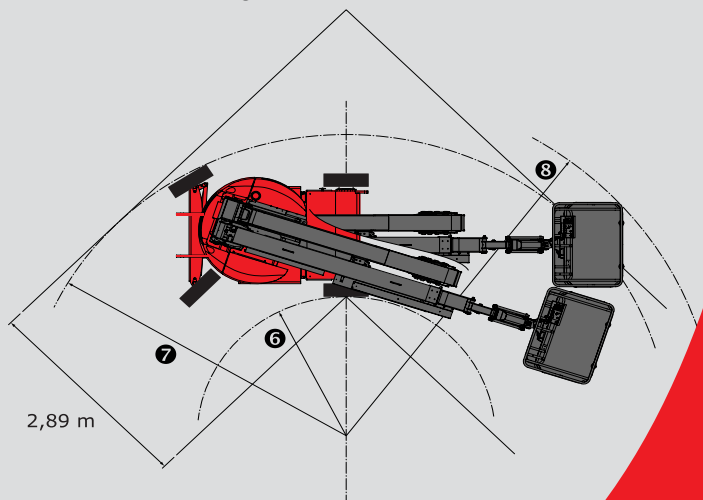
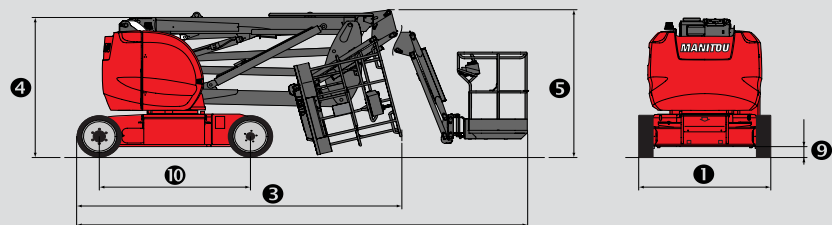
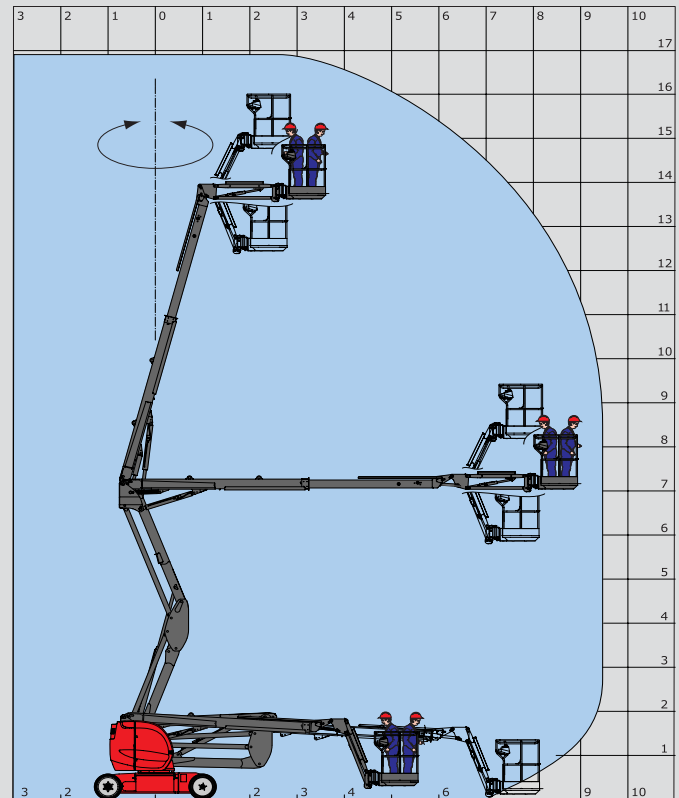

The equipment supplied with each model may differ from that described in this leaflet.  
 For more details, contact your MANITOU dealer.

