



Volvo Construction Equipment

ECR235E

Volvo Excavators 23.7-27.8 t 175 hp





Volvo ECR235E in detail

Engine

The latest generation, Volvo engine Tier 4f / Stage IV emissions compliant diesel engine fully meets the demands of the latest, emissions regulations. Featuring Volvo Advanced Combustion Technology (V-ACT), it is designed to deliver superior performance and fuel efficiency. The engine uses precise, high pressure fuel injectors, turbo charger and air-to-air intercooler, and electronic engine controls to optimize machine performance. Air Filter: 3-stage with precleaner Automatic Idling System: Reduces engine speed to idle when the levers and pedals are not activated resulting in less fuel consumption and low cab noise levels.

ECR235E

Engine	Volvo	D6J
Max power at	r/s / r/min	30 / 1 800
Net, ISO 9249/SAE J1349	kW / hp	128 / 174
Gross, ISO 14396/SAE J1995	kW / hp	129 / 175
Max torque at	Nm/ r/min	850 / 1 350
No. of cylinders		6
Displacement	l	5.7
Bore	mm	98
Stroke	mm	126

Electrical system

Well protected high-capacity electrical system. Waterproof double-lock harness plugs are used to secure corrosion-free connections. The main relays and solenoid valves are shielded to prevent damage. The master switch is standard. Contronics provides advanced monitoring of machine functions and important diagnostic information.

Voltage	V	24
Batteries	V / Ah	2 x 12 / 150
Alternator	V / Ah	28 / 110
Start motor	V / kW	24 x 5.5

Swing system

The swing system uses an axial piston motors, driving a planetary gearbox for maximum torque. An automatic holding brake and antirebound valve are standard

Max. slew speed	r/min	12
Max. slew torque	kNm	83

Drive

Each track is powered by an automatic two-speed shift travel motor. The track brakes are multi-disc, spring-applied and hydraulic released. The travel motor, brake and planetary gears are well protected within the track frame.

Max. drawbar pull	kN	208.9
Max. travel speed	km/h	3.0 / 5.5
Gradeability	°	35

Undercarriage

Robust X-shaped frame with greased and sealed track chains as standard.

Track shoe		2 x 49
Link pitch	mm	190
Shoe width, triple grouser	mm	600 / 700 / 800 / 900
Shoe width, triple grouser, HD	mm	600
Shoe width, double grouser	mm	700
Shoe width, rubber grouser	mm	600
Bottom rollers		2 x 8
Top rollers		2 x 2

Hydraulic system

The hydraulics system, combined with the fully electronic control system and advanced ECO mode, has been optimized to work in harmony with engine to match the engine power, reduce power loss and improve controllability and response time.

The following important functions are included in the system:

Summation system: Combines the flow of both hydraulic pumps to ensure quick cycle times and high productivity.

Arm priority: Gives priority to the arm operation for faster cycle times in leveling and for increased bucket filling when digging.

Swing priority: Gives priority to swing functions for faster simultaneous operations.

Regeneration system: Prevents cavitation and provides flow to other movements during simultaneous operations for maximum productivity.

Power boost: All digging and lifting forces are increased.

Holding valves: Boom and arm holding valves prevent the digging equipment from creeping.

Main pump, Type 2 x variable displacement axial piston pumps

Maximum flow	l/min	2 x 207
--------------	-------	---------

Pilot pump, Type Gear pump

Maximum flow	l/min	1 x 18
--------------	-------	--------

Relief valve setting:

Implement	MPa	34.3 / 36.3
Travel circuit	MPa	34.3
Slew circuit	MPa	27.9
Pilot circuit	MPa	3.9

Hydraulic motors

Travel: Variable displacement axial piston motor with mechanical brake

Slew: Fixed displacement axial piston motor with mechanical brake

Hydraulic cylinders

Mono boom		2
Bore x Stroke	ø x mm	130 x 1 420
1st boom of 2 piece boom		2
Bore x Stroke	ø x mm	130 x 1 345
2nd boom of 2 piece boom		1
Bore x Stroke	ø x mm	160 x 1 070
Arm		1
Bore x Stroke	ø x mm	135 x 1 520
Bucket		1
Bore x Stroke	ø x mm	120 x 1 065
Dozer blade		2
Bore x Stroke	ø x mm	140 x 320

Service refill capacities

Fuel tank		286
Hydraulic system, total		280
Hydraulic tank		126
AdBlue tank		24.9
Engine oil		25
Engine coolant		30
Swing reduction unit		7
Travel reduction unit		2 x 5

Cab

The operator's cab has easy access via a wide door opening. The cab is supported on hydraulic dampening mounts to reduce shock and vibration levels. These along with sound

absorbing lining provide low noise levels. The cab has excellent all-round visibility. The front windshield can easily slide up into the ceiling, and the lower front glass can be removed and stored in the side door.

Integrated air-conditioning and heating system: The pressurized and filtered cab air is supplied by an automatically-controlled fan. The air is distributed throughout the cab from 14 vents.

Ergonomic operator's seat: The adjustable seat and joystick console move independently to accommodate the operator. The seat has nine different adjustments plus a seat belt for the operator's comfort and safety.

Sound Level

Sound level in cab according to IS		
LpA (standard)	dB(A)	71
LpA (tropical)	dB(A)	72
External sound level according to ISO 639		æ (2000/14/EC)
LwA (standard)	dB(A)	101
LwA (tropical)	dB(A)	102



Specifications

MACHINE WEIGHTS AND GROUND PRESSURE				
Description	Shoe width	Operating weight	Ground pressure	Overall width
	mm	kg	kPa	mm
		ECR235EL		
		5.7m boom, 2.9m arm, 908kg / 1 090l bucket, 6 200kg counterweight		
Triple grouser	700	25 040	44.1	3 090

Specifications

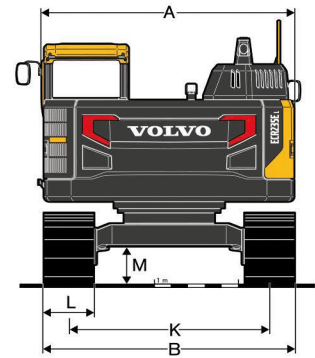
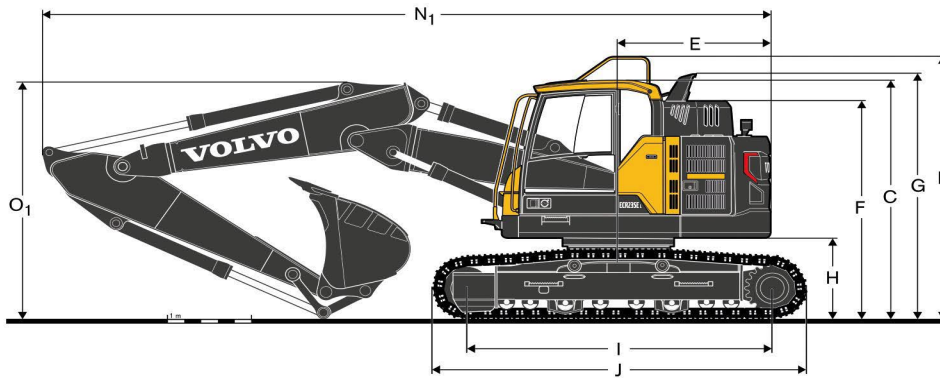
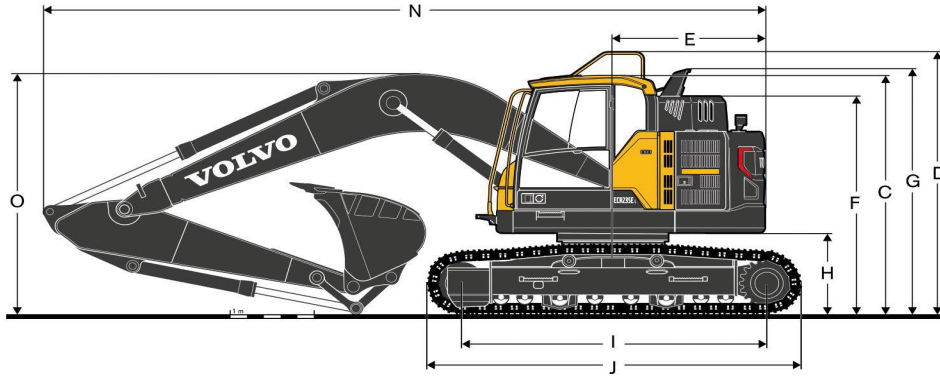

Description	Unit	ECR235EL
Boom	m	5.7 mono or 5.76 2-piece
Arm	m	2.9
A Overall width of upper structure	mm	2 990
B Overall width	mm	3 090
C Overall height of cab	mm	2 965
D Overall height of guardrail(unfolded)	mm	3 365
D' Overall height of guardrail(folded)	mm	2 925
E Tail swing radius	mm	1 810
F Overall height of engine hood	mm	2 780
G Overall height of diffuser	mm	3 035
H Counterweight clearance *	mm	1 025
I Tumbler length	mm	3 660
J Track length	mm	4 460
K Track gauge	mm	2 390
L Shoe width	mm	700
M Min. ground clearance *	mm	460
N Overall length	mm	9 010
N ₁ Overall length	mm	9 065
O Overall height of boom	mm	3 190
O ₁ Overall height of boom	mm	3 030

* Without shoe grouser.

1 2-piece boom

Specifications

WORKING RANGES

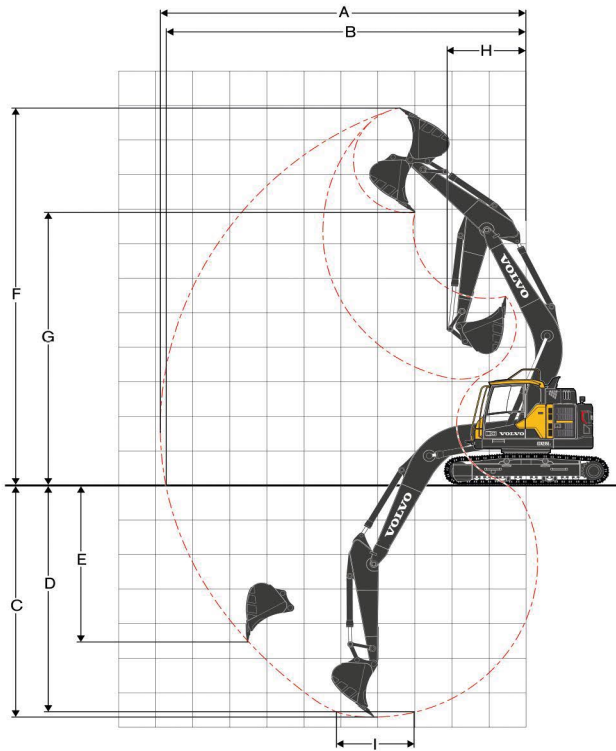

Description	Unit	ECR235E	
Boom	m	5.7 mono	
Arm	m	2.9	
A Max. digging reach	mm	9 890	
B Max. digging reach on ground	mm	9 735	
C Max. digging depth	mm	6 755	
D Max. digging depth (l = 2.44m level)	mm	6 550	
E Max. vertical wall digging depth	mm	5 685	
F Max. cutting height	mm	10 915	
G Max. dumping height	mm	7 870	
H Min. front swing radius	mm	2 170	



LIFTING CAPACITY ECR235EL

Lifting capacity at the arm end without bucket.

For lifting capacity including bucket, simply subtract actual weight of the direct fit bucket or the bucket with quick coupler from the following values.

	Lifting hook related to ground level	1.5 m		3.0 m		4.5 m		6.0 m		7.5 m		Max. reach		m
		Along UC	Across UC	Along UC	Across UC	Along UC	Across UC	Along UC	Across UC	Along UC	Across UC	Along UC	Across UC	
Boom : 5.7m	9.0m kg	-	-	-	-	-	-	-	-	-	-	*5 830	*5 830	4.0
Arm : 2.9m	7.5m kg	-	-	-	-	*6 150	*6 150	*4 920	*4 920	-	-	*4 830	*4 830	6.0
Shoe : 700mm	6.0m kg	-	-	-	-	*6 530	*6 530	*6 380	5 520	-	-	*4 530	4 080	7.2
CWT : 6 200kg	4.5m kg	-	-	*10 230	*10 230	*8 010	*8 010	*7 000	5 360	5 930	3 750	*4 490	3 440	7.9
	3.0m kg	-	-	-	-	*10 230	7 810	*8 000	5 100	5 810	3 640	*4 650	3 120	8.3
	1.5m kg	-	-	-	-	*12 250	7 260	7 950	4 840	5 670	3 510	4 820	2 990	8.4
	0.0m kg	-	-	*6 180	*6 180	12 240	6 950	7 730	4 650	5 560	3 410	4 920	3 030	8.2
	-1.5m kg	*6 750	*6 750	*10 980	*10 980	12 120	6 850	7 630	4 560	5 520	3 380	5 340	3 270	7.7
	-3.0m kg	*11 760	*11 760	*17 000	13 440	*12 150	6 900	7 660	4 580	-	-	6 330	3 860	6.8
	-4.5m kg	-	-	*13 310	*13 310	*9 670	7 100	-	-	-	-	*7 590	5 390	5.5

Notes: 1. Machine in "Fine Mode-F" (Power Boost) for lifting capacities. 2. The above loads are in compliance with SAE J1097 and ISO 10567 Hydraulic Excavator Lifting Capacity Standards. 3. Rated loads do not exceed 87% of hydraulic lifting capacity or 75% of tipping load. 4. Rated loads marked with an asterisk (*) are limited by hydraulic capacity rather than tipping load.



Equipment

STANDARD EQUIPMENT

	ECR235E
Engine	
Turbocharged, 4 stroke diesel engine with water cooling, direct injection and charged air cooler that meets Tier 4f EU (Stage IV) requirements	•
Air filter with indicator	•
Air intake heater	•
Electric engine shut-off	•
Fuel filter and water separator	•
Standard cooling system	•
Fuel filler pump: 30 l/min with auto stop	•
Alternator, 110 A	•
Electric/Electronic control system	
Contronics	
Advanced mode control system	•
Self-diagnostic system	•
Machine status indication	•
GSM/GPS Caretrack and 3yr-Caretrack subscription	•
Engine speed sensing power control	•
Automatic idling system	•
One-touch power boost	•
Safety stop/start function	•
Adjustable LCD color monitor	•
Master electrical disconnect switch	•
Engine restart prevention circuit	•
High-capacity halogen or LED lights: Halogen	
Frame-mounted: 1, Boom-mounted: 2 LED	•
Frame-mounted: 1, Boom-mounted: 2	•
Batteries, 2 x 12 V / 100 Ah	•
Batteries, 2 x 12 V / 150 Ah	•
Start motor, 24 V / 5.5 kW	•
Hydraulic system	
Boom hose rupture valve with overload warning device	•
Arm hose rupture valve	•
Automatic sensing hydraulic system	
Summation system	•
Boom priority	•
Arm priority	•
ECO mode fuel saving technology	•
Boom, arm and bucket regeneration valves	•
Swing anti-rebound valves	•
Boom and arm holding valves	•
Multi-stage filtering system	•
Boom cylinders (x2)	•
Cylinder cushioning	•
Cylinder contamination seals	•
Auxiliary hydraulic valve	•
Automatic two-speed travel motors	•
Hydraulic oil, longlife oil 46	•
Frame	
Access way with handrail	•
Tool storage area	•
Punched metal anti-slip plates	•
Under cover (heavy duty)	•
3 200kg counterweight	•
6 200kg counterweight	•

	ECR235E
Cab and interior	
ROPS (ISO12117-2) certified cab with openable roof hatch	•
Silicon oil and rubber mounts with spring	•
Control lock out lever	•
Travel pedals and hand levers	•
Adjustable operator seat with heater and joystick control console	•
Control joysticks with 4 switches each	•
Heater & air-conditioner, automatic	•
Flexible antenna	•
Radio with AUX, USB Jack and Bluetooth	•
Cab, all-weather sound suppressed, includes:	
Cup holders	•
Door locks	•
Tinted glass	•
Floor mat	•
Horn	•
Large storage area	•
Pull-up type front window	•
Removable lower windshield	•
Seat belt	•
Safety glass	•
Sun screens, front, roof, rear	•
Windshield wiper with intermittent feature	•
Rear view camera	•
Master key	•
Undercarriage	
Under cover	•
Hydraulic track adjusters	•
Greased and sealed track link	•
Track Guard	•
Digging equipment	
4.6m mono boom	
5.7m mono boom	•
2.5m arm	•
2.9m arm	•
Linkage	•
Manual centralized lubrication	•
Service	
Tool kit, daily maintenance	•

OPTIONAL EQUIPMENT

	ECR235E
Engine	
Block heater: 120 V or 240 V	•
Diesel coolant heater, 5 kW	•
Water separator with heater	•
Auto engine shutdown	•
Tropical cooling system	•
Reversible cooling fan	•
Electric	
Extra work lights (Halogen or LED):	
Cab-mounted 2 (front 1, rear 1)	•
Counterweight-mounted 1	•
Travel alarm	•
Anti-theft system	•
Rotating warning beacon	•