



Volvo Construction Equipment

# EWRI50E

Volvo Excavators 15.4-17.9 t 105 kW



# SHORT SWING PERFORMANCE

Swing into action, and take on the jobs that a conventional excavator can't, with improved lifting capacity, so you won't have to compromise on reach, lifting or digging performance. The market leading tail swing of the EWR150E, at 1 720 mm, and the short tail swing of the EWR170E, at 1 790 mm make for efficient and safe work in confined spaces.



*The short swing radius is clearly a major benefit, as it enables us to work in a tight residential environment without obstructing traffic.  
On-site manager Thorsten Bargatsky, Gebr. Kickartz GmbH, Germany*



# Volvo EWR150E in detail

## Engine

Volvo Construction Equipment is ready to comply with the tough new EU Stage IV legislation for off-road vehicles with the introduction of a cascade of innovations in its new generation engines with Volvo Advanced combustion technology (V-ACT).  
Volvo machines are equipped with in-line turbo charged diesel engine with high pressure unit injector system. The engine features an externally cooled exhaust gas re-circulation (E-EGR), a Diesel Particulate Filter (DPF) and a Selective Catalytic Reduction (SCR) with AdBlue.

Engine	Volvo	D4J
Max. power at	r/min	2 000
Net (ISO9249/SAEJ1349)	kW	102
	hp	139
Gross (ISO 14396/SAE J1995)	kW	105
	hp	143
Max. torque	Nm	605
at engine speed	r/min	1 500
No. of cylinders		4
Displacement	l	4.04
Bore	mm	101
Stroke	mm	126

## Electrical system

High-capacity electrical system that is well protected. Waterproof double-lock harness plugs are used to secure corrosion-free connections. The main relays and solenoid valves are shielded to prevent damage. The master switch is standard.

Voltage	V	24
Batteries	V	2 x 12
Battery capacity	Ah	2 x 100
Alternator	V/Ah	24/120
Alternator rating	W	3 360

## Undercarriage

Drive train: A variable axle piston motor in combination with a power shift gearbox supplies 3 speeds. The gearbox distributes the energy via propeller shafts to the axles.  
2 different undercarriages : a) Welded radial blade only with EW140 drive train. b) Bolted undercarriage with parallel blade with EW160 drivetrain and the option to add outriggers.  
Wheels: Alternative single and twin wheels available.  
Front axle: Robust excavator axle with automatic or operator controlled front axle oscillation lock.

Oscillating	± °	9
with mudguards	± °	6
Twin wheels	type	10/11-20
Tractive force (net)	kN	88 / 111
Travel speed, on road	km/h	20 / 30 / 35
Travel speed, off road	km/h	5.0 / 8.5
Travel speed, creep	km/h	3
Min. turning radius	m	7.3

## Swing system

The superstructure is slewed by the means of a radial piston motor without reduction gear.  
Automatic slew holding brake and anti-rebound valve are standard.

Max. slew speed	r/min	9
-----------------	-------	---

## Brake system

Service brakes: servo-hydraulically manoeuvred self-adjusting wet multidiscs with two separate brake circuits.  
Parking brake: negative wet disc in gear housing, spring applied and pressure released.  
Digging brake: service brake with mechanical lock system.  
Security system: The 2-circuit travel brakes are supplied with two accumulators in the event of failure in the service brake system.

## Sound Level

In cab, acc. to ISO 6396		
LpA	dB(A)	71
External, acc. to ISO 6395 and Directive 2000/14/EC		
LwA	dB(A)	100

## Hydraulic system

Load sensing hydraulic system with pressure compensated valves. Load independence of movements. Flow sharing feature, combined with a high flow pump (power regulation). The system gives superior manoeuvrability and fast movements, for optimal working result and economy.  
The following working modes are included in the system:  
Parking mode (P): Parking position for optimal safety.  
Travel mode (T): Engine speed is controlled by travel pedal stroke for low fuel consumption and noise.  
Working mode (W): Full working flow with adjustable engine rpm for normal working and best speed utilisation.  
Customer mode (C): Operator can set proper oil flow in accordance with job conditions.  
Power Boost: All digging and lifting forces are increased.

### Main pump (type low noise axial piston pump)

Max. flow	l/min	275
-----------	-------	-----

### Brake + steering pump (type low noise gear pump)

Max. flow	l/min	50
-----------	-------	----

### Attachment circuit

Max. flow	l/min	220
-----------	-------	-----

### Relief valve setting pressure

Implement	MPa	32.5 / 36
Travel system	MPa	36
Pilot system	MPa	3.5

## Total Machine Weights

Machine with 4.5 m monoblock boom, 2.45 m dipper arm, quickfit S6, 410 kg / 580 l bucket.		
With welded radial dozer blade front and outriggers rear	kg	16 500
With welded radial dozer blade rear only	kg	15 400
With bolted dozer blade front and outriggers rear	kg	17 400
With bolted dozer blade rear only	kg	16 300
Machine with 4.7m 2-piece boom, 2.45 m dipper arm, quickfit S6, 410 kg / 580 l bucket.		
With welded radial dozer blade front and outriggers rear	kg	17 000
With welded radial dozer blade rear only	kg	15 900
With bolted dozer blade front and outriggers rear	kg	17 900
With bolted dozer blade rear only	kg	16 800

## Service Refill

Fuel tank	l	200
DEF/AdBlue® tank	l	25
Hydraulic system, total	l	230
Hydraulic tank	l	104
Engine oil	l	16
Engine coolant	l	32
Transmission	l	2.5

## Axle differential:

Front axle	l	9.5
Rear axle	l	12.5
Final drive	l	4 x 2.5

## Cab

New design Volvo Care Cab with operator protective structure, large and roomy interior. One way travel pedal with rocker switch control (F-N-R) on the right joystick. One-touch release for digging brake pedal.  
Audio system with remote control and Bluetooth system for hands free phoning. Independently adjustable joystick consoles.  
Excellent all-round visibility provided by maximized cab class, transparent roof hatch, 2-piece sliding door window and long stroke, easy to adjust and new narrow steering column. The liftable front windshield can easily be stored in the inside roof space and clipped in position. The removable lower front glass can be stored in the side door pocket. Interior lighting consists of one reading light and one light with timer.  
The pressurized and filtered cab air is supplied by a 14-vent climate-control providing fast defrosting and high cooling and heating performance. Viscous/spring mounted suspension cushions protect the operator from vibrations.  
Deluxe air-suspension seat with adjustable seat suspension, height, tilt, recline and forward-backward settings.(option)  
Adjustable, easy to read 8.3" LCD color monitor provides real time information of machine functions and important diagnostic information and is switchable to rear view camera monitor( standard ) / side view camera ( option ). A new multi function button on left hand joystick with programmable function to improve the operator comfort.  
Refrigerant of the type R134a is used when this machine is equipped with air conditioning. Contains fluorinated greenhouse gas R134a, Global Warming Potential 1.430 t CO2-eq.

# Caractéristiques techniques

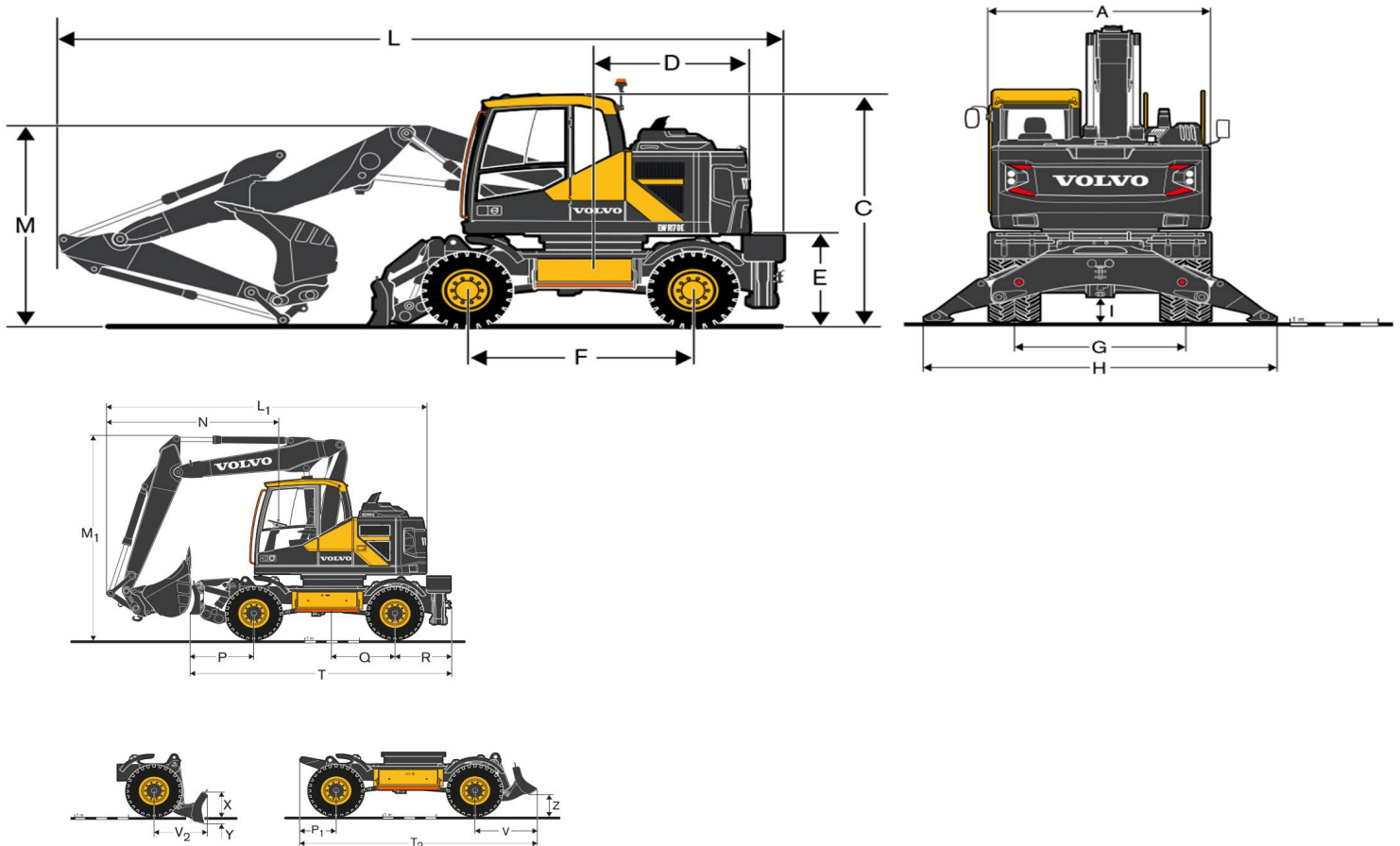

DIMENSIONS		EWR150E	
Description	Unité	Flèche articulée	
	m	4.7	
A	Largeur hors tout à la tourelle	mm	2 520
B	Largeur hors tout	mm	2 540
C	Hauteur hors tout à la cabine	mm	3 150
D	Rayon d'orientation arrière	mm	1 720
E	Garde au sol sous le contre poids	mm	1 260
F	Empattement	mm	2 600
G	Voie	mm	1 940
H	Largeur aux stabilisateurs (avant ou arrière)	mm	3 990
I	Garde au sol min.	mm	340
Description	Unité	Flèche articulée	
	m	4.7	
	Balancier		
	m	2.6	
L	Longueur hors tout	mm	7 790
M	Hauteur hors tout à la flèche	mm	3 040
L1	Longueur hors tout	mm	6 610
M1	Hauteur hors tout à la flèche	mm	3 970
N	Déport avant	mm	3 190

\*\* Sans godet

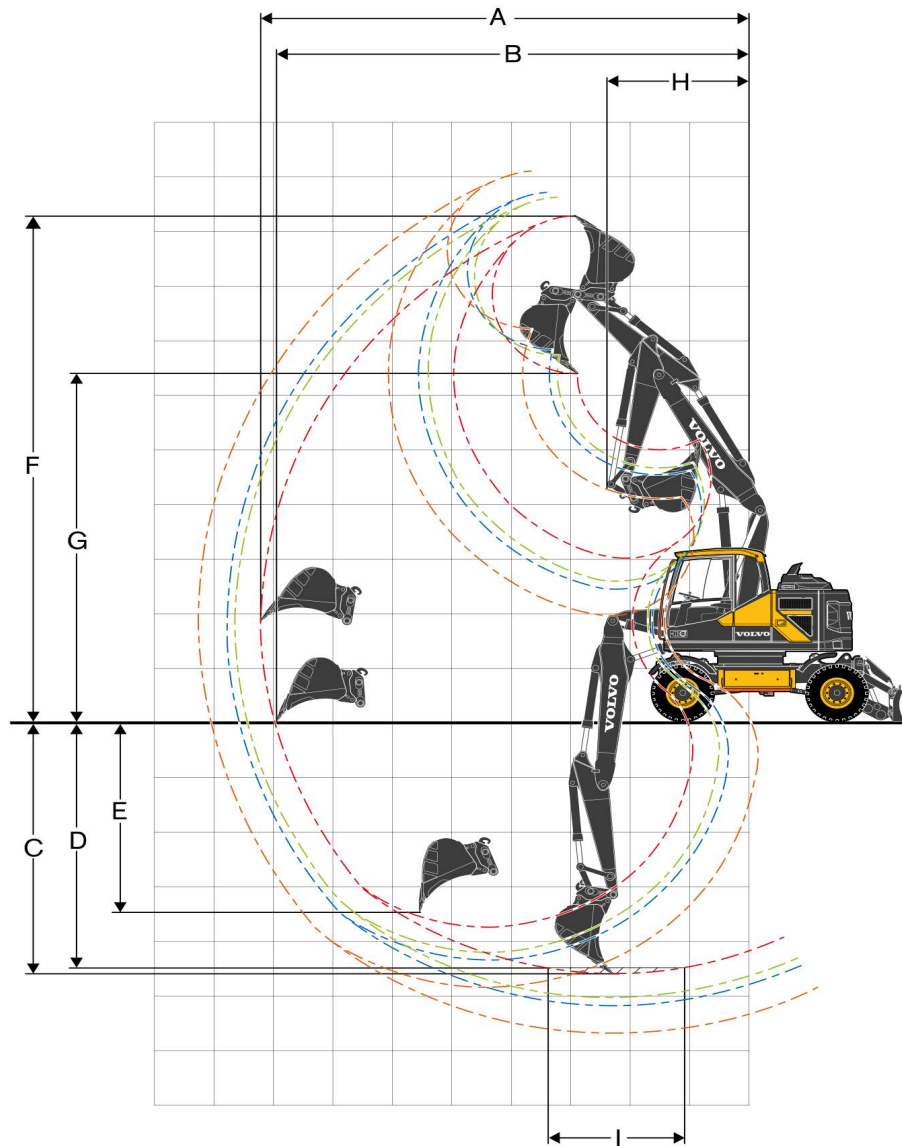

**WORKING RANGES WITH DIRECT FIT BUCKET**

		4.7 m 2-piece boom EWR150E	
		Unit	Arm
		m	2.6
A	Max. digging reach	mm	8 810
B	Max. digging reach on ground	mm	8 620
C	Max. digging depth	mm	5 240
D	Max. digging depth (l = 2 440 mm level)	mm	5 140
E	Max. vertical wall digging depth	mm	4 100
F	Max. cutting height	mm	9 670
G	Max. dumping height	mm	6 780
H	Min. front slew radius	mm	2 600

Note: 1. Bucket size based on SAE-J296, heaped material with a 1:1 angle of repose. | 2. "Max permitted sizes" are for reference only and are not necessarily available from the factory. | 3. "Max permitted sizes" are for heavy counterweight.



**LIFTING CAPACITY EWR150E - Welded undercarriage**

At the arm end, without bucket and quick fit. For lifting capacity including bucket/quick fit, simply subtract actual weight of those parts from the following values.  
With heavy counterweight. Unit: 1 000kg

	Lifting point	Reach from machine centre (u = support up/d = support down)																				
		1.5 m				3.0 m				4.5 m				6.0 m				Max.				
		Across UC		Along UC		Across UC		Along UC		Across UC		Along UC		Across UC		Along UC		Across UC		Along UC		Max.
		m	u	d	u	d	u	d	u	d	u	d	u	d	u	d	u	d	u	d	u	d
4.7 m 2 piece boom 2.6 m dipper arm Front radial blade Rear outriggers	7.5	-	-	-	-	-	-	-	-	3.0*	3.0*	3.0*	3.0*	-	-	-	-	3.0*	3.0*	3.0*	3.0*	4.5
	6	-	-	-	-	-	-	-	-	3.5*	3.5*	3.5*	3.5*	-	-	-	-	2.4	2.5*	2.5*	2.5*	6.0
	4.5	-	-	-	-	-	-	-	-	3.8	3.9*	3.9*	3.9*	2.4	3.6*	3.6*	3.6*	1.9	2.4*	2.4*	2.4*	6.8
	3	-	-	-	-	6.5	7.2*	7.2*	7.2*	3.5	4.9*	4.9*	4.9*	2.3	4.0	3.8	4.0*	1.7	2.4*	2.4*	2.4*	7.3
	1.5	-	-	-	-	-	-	-	-	3.3	5.8*	5.6	5.8*	2.2	3.8	3.6	4.4*	1.6	2.5*	2.5*	2.5*	7.4
	0	-	-	-	-	5.4	5.4*	5.4*	5.4*	3.1	5.7	5.4	6.3*	2.1	3.7	3.5	4.6*	1.6	2.8*	2.7	2.8*	7.1
	-1.5	-	-	-	-	5.4	8.9*	8.9*	8.9*	3.0	5.6	5.3	6.2*	2.0	3.7	3.5	4.5*	1.8	3.3	3.1	3.4*	6.6
4.7 m 2 piece boom 2.6 m dipper arm Radial Blade Rear	7.5	-	-	-	-	-	-	-	-	3.1*	3.0*	3.1*	3.0*	-	-	-	-	3.1*	3.0*	3.1*	3.0*	4.5
	6	-	-	-	-	-	-	-	-	3.5*	3.5*	3.5*	3.5*	-	-	-	-	2.3	2.5*	2.6*	2.5*	6.0
	4.5	-	-	-	-	-	-	-	-	3.6	3.9*	3.9*	3.9*	2.3	2.6	3.6*	3.6*	1.8	2.1	2.4*	2.4*	6.8
	3	-	-	-	-	6.1	7.2*	7.1*	7.2*	3.3	3.9	4.8*	4.9*	2.2	2.5	3.6	4.0*	1.6	1.8	2.4*	2.4*	7.3
	1.5	-	-	-	-	-	-	-	-	3.0	3.6	5.4	5.8*	2.0	2.4	3.5	4.4*	1.5	1.7	2.5*	2.5*	7.4
	0	-	-	-	-	5.1	5.4*	5.5*	5.4*	2.9	3.4	5.2	6.3*	1.9	2.3	3.4	4.6*	1.5	1.8	2.6	2.8*	7.1
	-1.5	-	-	-	-	5.1	6.1	9.0*	8.9*	2.8	3.3	5.1	6.2*	1.9	2.2	3.3	4.5*	1.7	2.0	3.0	3.4*	6.6

Notes: 1. Working pressure with Power Boost = 37.5 MPa. 2. The above values are in compliance with ISO standard 10 567. They do not exceed 87 % of hydraulic lifting capacity or 75 % of tipping load, with the machine on firm, level ground. 3. Load capacities marked with an asterisk (\*) are limited by machine's hydraulic lifting capacity rather than tipping load.



# Équipement

## ÉQUIPEMENT STANDARD

EWR150E

### Moteur

Moteur diesel 4 temps, turbocompressé, à refroidissement liquide, injection directe et refroidisseur de l'air d'admission. Conforme aux normes antipollution UE Étape IV.	•
Préchauffage de l'air d'admission	•
Mode ECO	•
Filtre à carburant et décanteur	•
Pompe de remplissage de carburant : 50 L/min, avec arrêt automatique	•
Radiateur en aluminium	•

### Système électrique / électronique

Système Contronic de contrôle permanent et de diagnostic	•
Système de ralenti automatique réglable	•
Suppression hydraulique (Power Boost) par contacteur à impulsion	•
Écran de contrôle orientable	•
Fonction de sécurité arrêt/marche et interrupteur général	•
2 feux de travail halogènes montés sur la tourelle	•
Alternateur 120 A	•
Batteries, 2 x 12 V / 120 Ah	•
Démarrateur 24 V / 5,5 kW	•
CareTrack GSM ou satellite	•
Caméra de vision arrière	•
Caméra latérale côté droit	•

### Tourelle

Feux arrière LED	•
Passerelle de service antidérapante	•
Points de graissage centralisés pour la couronne d'orientation et la flèche	•

### Châssis inférieur

3 gammes de vitesse : approche lente / lente (hors route) / rapide (route), max. 35 km/h	•
Essieu avant oscillant $\pm 9^\circ$ sans garde-boue / $\pm 6^\circ$ avec garde-boue	•
Freins de service à double circuit indépendant	•
Arbres de transmission sans entretien	•

### Système hydraulique

Système hydraulique à détection de charge	•
Système de sécurité de suppression (servo-accumulateur)	•
Ventilateur de refroidissement entraîné par visco-coupleur à régulation proportionnelle	•
Clapets de sécurité de rupture de flexibles sur les vérins de flèche et de balancier	•
Huile hydraulique longue durée ISO VG46	•

### Cabine et poste de conduite

Cabine Volvo CareCab avec structure ROPS et vitre de toit fixe	•
Porte-gobelet	•
Porte verrouillable	•
Vitres en verre feuilleté, teinté clair	•
Tapis de sol	•
Avertisseur sonore	•
Nombreux compartiments de rangement	•
Vitre supérieure de pare-brise relevable	•
Vitre inférieure de pare-brise amovible	•
Ceinture de sécurité à enrouleur	•
Essuie-glace de pare-brise avec lave-glace et fonction intermittente	•
Chauffage / climatisation à régulation automatique	•
Suspension de la cabine par silentbloks huile / ressorts	•
Siège entièrement réglable avec consoles de commande réglables	•
Colonne de direction réglable	•
Levier de verrouillage des commandes hydrauliques	•
Manipulateurs de commande, à contacteurs proportionnels ou L8	•
Autoradio / Bluetooth avec prise USB	•
Pare-soleils (pare-brise, vitre de toit et vitre arrière)	•
Clé unique contact / portes	•
Contacteur multifonction programmable intégré au manipulateur gauche	•

### Groupe de travail

Fixations pour circuits hydrauliques auxiliaires supplémentaires	•
Points de graissage centralisés pour le balancier et le godet	•