



Volvo Construction Equipment

L120H

Volvo Wheel Loaders

21.6 t

276 hp





2009

Volvo sets the standard for the attachment bracket (ISO 23727)

2010

OptiShift
CareTrack

2016

Load Assist, powered by the award-winning Volvo Co-Pilot

2017

New generation OptiShift

With you for the long run

As your trusted partner in production, Volvo is here to support you with the best equipment for the job. Boasting a comprehensive portfolio of attachments designed to complement your machines performance, as well as a range of services to boost your profitability, we'll help you tailor the perfect package to suit your business needs.





Volvo L120H in detail

Engine

The engine is a straight six cylinder, four stroke, turbo charged diesel engine with direct injection and charge air cooler. The engine meet US Tier 4 final and California Tier 4 final emission requirements and EU Stage IV emission requirements. The engine uses a common rail fuel system controlled by the engine control module (ECM). Engines with ACT (advanced combustion technology) feature split injection and turbocharger with mechanical wastegate. The exhaust after treatment system (EATS) is equipped with a diesel oxidation catalyst (DOC), a diesel particulate filter (DPF) and a SCR system to reduce emissions. Cooled exhaust gas recirculation (EGR) also reduces emissions.

L120H

| | | |
|-------------------------|-------|-------------|
| Engine | Volvo | D8J |
| Max. power at | r/min | 1 500 |
| SAE J1995 gross | kW | 203 |
| | hp | 276 |
| ISO 9249, SAE J1349 net | kW | 203 |
| | hp | 276 |
| Max. torque at | r/min | 1 450 |
| SAE J1995 gross | Nm | 1 320 |
| ISO 9249, SAE J1349 net | Nm | 1 317 |
| Economic working range | r/min | 850 - 2 100 |
| Displacement | l | 7.8 |

L120H

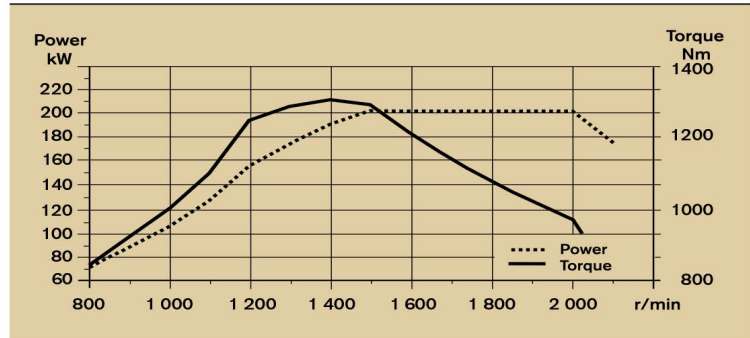

Drivetrain

Torque converter: Single-stage.

Transmission: Volvo countershaft transmission with single lever control. Fast and smooth shifting of gears with Pulse Width Modulation (PWM) valve.

Transmission: Volvo Automatic Power Shift (APS) with fully automatic shifting 1-4 and mode selector with 4 different gear shifting programs, including AUTO. OptiShift transmission is also available as an option.

Axes: Volvo fully floating axle shafts with planetary hub reductions and cast steel axle housing. Fixed front axle and oscillating rear axle. % differential lock on the front axle.

| | | L120H |
|------------------------------------|-------|-----------------|
| Transmission | Volvo | HTE 206C |
| Torque multiplication, stall ratio | | 2.47:1 |
| Maximum speed, forward/reverse | | |
| 1st gear | km/h | 7 |
| 2nd gear | km/h | 13.5 |
| 3rd gear | km/h | 28 |
| 4th gear | km/h | 40 |
| Note: 4th gear limited by ECU | | |
| Measured with tires | | 750/65R25 |
| Front axle/rear axle | | AWB 31 / AWB 30 |
| Rear axle oscillation | ± ° | 13 |
| Ground clearance | mm | 460 |
| at oscillation | ° | 130 |

Electrical System

Central warning system: Contronic electrical system with central warning light and buzzer for following functions: - Serious engine fault - Low steering system pressure - Over speed warning engine - Interruption in communication (computer fault) Central warning light and buzzer with the gear engaged for the following functions: - Low engine oil pressure - High engine oil temperature - High charge air temperature - Low coolant level - High coolant temperature - High crank case pressure - Low transmission oil pressure - High transmission oil temperature - Low brake pressure - Engaged parking brake - Fault on brake charging - Low hydraulic oil level - High hydraulic oil temperature - Overspeeding in engaged gear - High brake cooling oil temperature front and rear axles.

| | | L120H |
|--------------------------------|-----|----------|
| Voltage | V | 24 |
| Batteries | V | 2 x 12 |
| Battery capacity | Ah | 2 x 170 |
| Cold cranking capacity, approx | A | 1 000 |
| Alternator rating | W/A | 2 280/80 |
| Starter motor output | kW | 5.5 |

Brake System

Service brake: Volvo dual-circuit system with nitrogen charged accumulators. Outboard mounted hydraulically operated, fully sealed oil circulation cooled wet disc brakes. The operator can select automatic declutch of the transmission when braking by selecting the setting in the contronics.

Parking brake: Dry disc brake. Applied by spring force, electro-hydraulic release with a switch on the instrument panel.

Secondary brake: Dual brake circuits with rechargeable accumulators. One circuit or the parking brake fulfills all safety requirements.

Standard: The brake system complies with the requirements of ISO 3450.

| | | L120H |
|---------------------------------------|--|---------|
| Number of brake discs per wheel front | | 1 |
| Accumulators | | 3 x 1.0 |



Cab

Instrumentation: All important information is centrally located in the operator's field of vision. Display for Contronic monitoring system.
Heater and defroster: Heater coil with filtered fresh air and fan with auto and manual(11 speed) setting. Defroster vents for all window areas.
Operator's seat: Operator's seat with adjustable suspension and retractable seatbelt. The seat is mounted on a bracket on the rear cab wall and floor. The forces from the retractable seatbelt are absorbed by the seat rails.
Standard: The cab is tested and approved according to ROPS (ISO 3471, SAE J1040), FOPS (ISO 3449). The cab meets with requirements according to ISO 6055 (Operator overhead protection - Industrial trucks) and SAE J386 ("Operator Restraint System").
 Refrigerant of the type R134a is used when this machine is equipped with air conditioning. Contains fluorinated greenhouse gas R134a, Global Warming Potential 1.430 t CO2-eq.

| | | L120H |
|---|---------------------|--------------|
| Emergency exit: Use emergency hammer to b | | |
| Ventilation | m ³ /min | 9 |
| Heating capacity | kW | 16 |
| Air conditioning (optional) | kW | 7.5 |

Lift Arm System

Torque Parallel linkage (TP-linkage) with high breakout torque and parallel movement throughout the entire lifting range.

| | | L120H |
|---------------------|----|--------------|
| Lift cylinders | | 2 |
| Cylinder bore | mm | 150 |
| Piston rod diameter | mm | 80 |
| Stroke | mm | 676 |
| Tilt cylinder | | 1 |
| Cylinder bore | mm | 210 |
| Piston rod diameter | mm | 110 |
| Stroke | mm | 412 |

Hydraulic System

System supply: Two load-sensing axial piston pumps with variable displacement. The steering system always has priority.
Valves: Double-acting 2-spool valve. The main valve is controlled by a 2-spool pilot valve.
Lift function: The valve has four positions; raise, hold, lower and floating position. Inductive/magnetic automatic boom kickout can be switched on and off and is adjustable to any position between maximum reach and full lifting height.
Tilt function: The valve has three functions including rollback, hold and dump. Inductive/magnetic automatic tilt can be adjusted to the desired bucket angle.
Cylinders: Double-acting cylinders for all functions
Filter: Full flow filtration through 10 micron (absolute) filter cartridge.

| | | L120H |
|---|-------|--------------|
| Working pressure maximum, pump 1 for working hydraulic system | MPa | 29.0 ± 0.5 |
| Flow at engine speed | l/min | 128 |
| Working pressure maximum, pump 2 for steering-, brake-, pilot- and working hydraulic system | MPa | 10 |
| Flow at engine speed | l/min | 128 |
| Working pressure maximum, pump 3 for brake- and cooling fan system | MPa | 10 |
| Flow at engine speed | l/min | 33 |
| Pilot system, working pressure | MPa | 10 |
| Cycle times | | |
| Lift | s | 5.4 |
| Tilt | s | 2.1 |
| Lower, empty | s | 2.5 |
| Total cycle time | s | 10 |

Steering System

Steering system: Load-sensing hydrostatic articulated steering.
System supply: The steering system has priority feed from a load-sensing axial piston pump with variable displacement.
Steering cylinders: Two double-acting cylinders.

| | | L120H |
|----------------------|-------|--------------|
| Steering cylinders | | 2 |
| Cylinder bore | mm | 80 |
| Rod diameter | mm | 50 |
| Stroke | mm | 486 |
| Working pressure | MPa | 21 |
| Maximum flow | l/min | 120 |
| Maximum articulation | ± ° | 40 |

Service Refill

Service accessibility: Electrically openable engine hood with large opening angle giving excellent access to the engine compartment. Fluid filters and component breather air filters promote long service intervals. Possibility to monitor, log and analyze data to facilitate troubleshooting.

| | | L120H |
|--------------------|---|--------------|
| Fuel tank | l | 270 |
| DEF/AdBlue® tank | l | 25 |
| Engine coolant | l | 43 |
| Hydraulic oil tank | l | 133 |
| Transmission oil | l | 38 |
| Engine oil | l | 22 |
| Axle oil front | l | 36 |
| Axle oil rear | l | 41 |

Sound Level

| | | L120H |
|--|-------|--------------|
| Sound level in cab according to ISO 6396/SAE J2105 | | |
| LpA | dB(A) | 68 |
| External sound level according to ISO 6395/SAE J2104 | | |
| LwA | dB(A) | 106 |



Specifications

| L120H | | |
|--|----|-------|
| Tires 23.5 R25 L3 | | |
| Standard boom | | |
| B | mm | 6 580 |
| C | mm | 3 200 |
| D | mm | 440 |
| F | mm | 3 380 |
| G | mm | 2 132 |
| J | mm | 3 760 |
| K | mm | 4 100 |
| O | ° | 54 |
| Pmax | ° | 50 |
| R | ° | 42 |
| R1* | ° | 45 |
| S | ° | 68 |
| T | mm | 119 |
| U | mm | 450 |
| X | mm | 2 070 |
| Y | mm | 2 670 |
| Z | mm | 3 340 |
| a2 | mm | 5 730 |
| a3 | mm | 3 060 |
| a4 | ±° | 40 |
| Standard boom with 3.3 m ³ STE H T bucket | | |
| Long boom with 2.6 m ³ STE P BOE bucket | | |

* Carry position SAE

Where applicable, specifications and dimensions are according to ISO 7131, SAE J732, ISO 7546, SAE J742, ISO 14397, SAE J818.

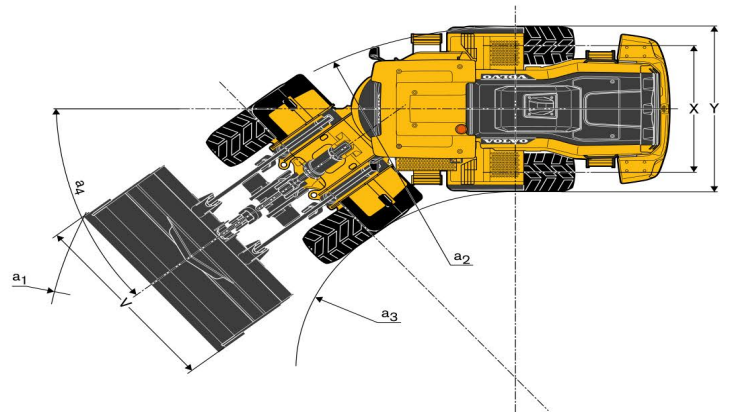
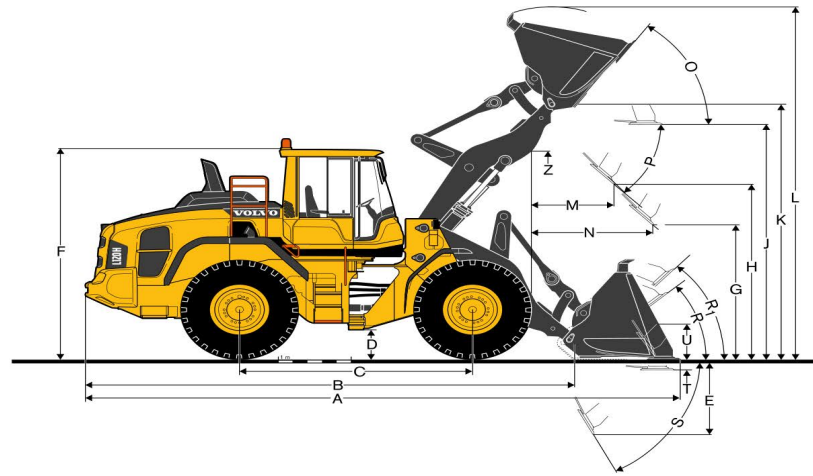

L120H

Sales code: WLA80832

Operating weight

(incl. logging cw 685 kg): 20 713 kg

Operating load: 6 400 kg



Specifications L120H

L120H

| | | GENERAL PURPOSE | |
|-------------------------------|----------------|---|--|
| Tires 23.5R25 XHA2 L3 | |  | |
| | | 3.6 m³ STE P BOE | |
| Volume, heaped ISO/SAE | m ³ | 3.6 | |
| Volume at 110% fill factor | m ³ | 4.0 | |
| Static tipping load, straight | kg | 14 810 | |
| at 35° turn | kg | 13 110 | |
| at full turn | kg | 12 610 | |
| Breakout force | kN | 172.9 | |
| A | mm | 8 050 | |
| E | mm | 1 230 | |
| H | mm | 2 900 | |
| L | mm | 5 750 | |
| M | mm | 1 190 | |
| N | mm | 1 800 | |
| V | mm | 3 000 | |
| a1 clearance circle | mm | 12 800 | |
| Operating weight | kg | 19 420 | |

* Measured with additional rehandling counterweight | ** With MICHELIN 23,5R25 XMINE D2 L5 Tire | *** Based on 3.0 m³ STE H T bucket



Equipment

STANDARD EQUIPMENT

| | L120H |
|---|-------|
| Engine | |
| Exhaust after-treatment system | • |
| Three stage air cleaner, pre-cleaner, primary and secondary filter | • |
| Indicator for coolant level | • |
| Preheating of induction air | • |
| Fuel pre-filter with water trap | • |
| Fuel filter | • |
| Crankcase breather oil trap | • |
| Exterior radiator air intake protection | • |
| Drivetrain | |
| Automatic Power Shift | • |
| Fully automatic gearshifting, 1-4 | • |
| PWM-controlled gearshifting | • |
| Forward and reverse switch by hydraulic lever console | • |
| Indicator glass for transmission oil level | • |
| Differentials: Front, 100% hydraulic diff lock. Rear, conventional. | • |
| Lock-up first gear | • |
| Electrical System | |
| 24 V, pre-wired for optional accessories | • |
| Alternator 24V/80A/2280W | • |
| Battery disconnect switch | • |
| Fuel gauge | • |
| Hour meter | • |
| Electric horn | • |
| Instrument cluster: | |
| Fuel level | |
| Diesel Exhaust Fluid/AdBlue level | • |
| Transmission temperature | |
| Coolant temperature | |
| Instrument lighting | |
| Lighting: | |
| Twin halogen front headlights with high and low beams | |
| Parking lights | • |
| Double brake and tail lights | |
| Turn signals with flashing hazard light function | |
| Halogen work lights (2 front and 2 rear) | |
| Contronic Monitoring System | |
| Monitoring and logging of machine data | • |
| Contronic display | • |
| Fuel consumption | • |
| Diesel Exhaust Fluid/AdBlue consumption | • |
| Ambient temperature | • |
| Clock | • |
| Test function for warning and indicator lights | • |
| Brake test | • |
| Test function, sound level at max fan speed | • |
| Warning and indicator lights: | |
| Battery charging | • |
| Parking brake | |
| Warning and display message: | |
| Regeneration | |
| Engine coolant temperature | |
| Charge-air temperature | |
| Engine oil temperature | |
| Engine oil pressure | |
| Transmission oil temperature | |
| Transmission oil pressure | |
| Hydraulic oil temperature | • |
| Brake pressure | |
| Parking brake applied | |
| Brake charging | |
| Overspeed at direction change | |
| Axle oil temperature | |
| Steering pressure | |
| Crankcase pressure | |
| Attachment lock open | |
| Safety Belt Warning | |
| Level warnings: | |
| Fuel level | |
| Diesel Exhaust Fluid/AdBlue level | |
| Engine oil level | • |
| Engine coolant level | |
| Transmission oil level | |
| Hydraulic oil level | |
| Washer fluid level | |
| Engine torque reduction in case of malfunction indication: | |
| High engine coolant temperature | |
| High engine oil temperature | |
| Low engine oil pressure | • |
| High crankcase pressure | |
| High charge-air temperature | |
| Engine shutdown to idle in case of malfunction indication: | |
| High transmission oil temperature | • |
| Slip in transmission clutches | |
| Keypad, background lit | • |
| Start interlock when gear is engaged | • |

STANDARD EQUIPMENT

| | L120H |
|--|-------|
| Hydraulic System | |
| Main valve, double acting 2-spool with hydraulic pilots | • |
| Variable displacement axial piston pumps (3) for: | |
| 1 Working hydraulics, Pilot hydraulics and Brake system | |
| 2 Working hydraulics, Pilot hydraulics, Steering and Brake system | • |
| 3 Cooling fan and Brake system | |
| Electro-hydraulic servo controls | • |
| Electronic hydraulic lever lock | • |
| Automatic boom kick-out | • |
| Automatic bucket positioner | • |
| Double-acting hydraulic cylinders | • |
| Indicator glass for hydraulic oil level | • |
| Hydraulic oil cooler | • |
| Brake System | |
| Dual brake circuits | • |
| Dual brake pedals | • |
| Secondary brake system | • |
| Parking brake, electro-hydraulic | • |
| Brake wear indicators | • |
| Cab | |
| ROPS (ISO 3471), FOPS (ISO 3449) | • |
| Single key kit door/start | • |
| Acoustic inner lining | • |
| Cigarette lighter, 24 V power outlet | • |
| Lockable door | • |
| Cab heating with fresh air inlet and defroster | • |
| Fresh air inlet with two filters | • |
| Automatic heat control | • |
| Floor mat | • |
| Dual interior lights | • |
| Interior rear-view mirrors | • |
| Dual exterior rear-view mirrors | • |
| Sliding window, right side | • |
| Tinted windshield glass | • |
| Retractable seatbelt (SAE J386) | • |
| Adjustable steering wheel | • |
| Storage compartment | • |
| Document pocket | • |
| Sun visor | • |
| Beverage holder | • |
| Windshield washer front and rear | • |
| Windshield wipers front and rear | • |
| Interval function for front and rear wipers | • |
| Service and Maintenance | |
| Engine oil remote drain and fill | • |
| Transmission oil remote drain and fill | • |
| Lubrication manifolds, ground accessible | • |
| Pressure check connections: transmission and hydraulic, quick-connects | • |
| Tool box, lockable | • |
| External Equipment | |
| Orange hand rails | • |
| Fenders, front and rear | • |
| Viscous cab mounts | • |
| Rubber engine and transmission mounts | • |
| Frame, joint lock | • |
| Vandalism lock prepared for | |
| Engine compartment | • |
| Radiator grille" | |
| Lifting eyes | • |
| Tie-down eyes | • |
| Fabricated counterweight | • |
| Counterweight, pre-drilled for optional guards | • |