



649090 EN-US (16/07/2018)

MLT 960 104JD ST4 S2

OPERATOR'S MANUAL
(ORIGINAL INSTRUCTIONS)



IMPORTANT

Carefully read and understand this instruction manual before using the telehandler.

It contains all information relating to operation, handling and telehandler equipment, as well as important recommendations to be followed.

This document also contains precautions for use, as well as information on the servicing and routine maintenance required to ensure the telehandler's continued safety of use and reliability.

WHenever you see this symbol it means:



WARNING! BE CAREFUL! YOUR SAFETY OR THE SAFETY OF THE TELEHANDLER IS AT RISK.

- This manual has been produced on the basis of the equipment list and the technical characteristics given at the time of its design.
- The level of equipment of the telehandler depends on the options chosen and the country of sale.
- According to the telehandler options and the date of sale, certain items of equipment/functions described herein may not be available.
- Descriptions and figures are non binding.
- MANITOU reserves the right to change its models and their equipment without being required to update this manual.
- The MANITOU network, consisting exclusively of qualified professionals, is at your disposal to answer all your questions.
- This manual is an integral part of the telehandler.
- It is to be kept in its storage space at all times for ease of reference.
- Hand this manual to the new owner if the telehandler is resold.

CALIFORNIA PROPOSITION 65 WARNINGS

⚠ WARNING

This product can expose you to lead which is known to the State of California to cause cancer and birth defects or other reproductive harm.

For more information go to www.P65Warnings.ca.gov

⚠ WARNING

Breathing diesel engine exhaust exposes you to chemicals known to the State of California to cause cancer and birth defects or other reproductive harm.

- Always start and operate the engine in a well-ventilated area.
- If in an enclosed area, vent the exhaust to the outside.
- Do not modify or tamper with the exhaust system.
- Do not idle the engine except as necessary.

For more information go to www.P65Warnings.ca.gov/diesel



SILICA DUST HAZARD

Exposure to crystalline silica (found in sand, soil and rocks) has been associated with silicosis, a debilitating and often fatal lung disease. Comply with all applicable rules and regulations for the workplace. Wear approved respiratory protection or use water spray or other means if there is no other way to control the dust.

A Silica rule "29 CFR 1929.1153" by the U.S. Occupational Safety and Health (OSHA) indicates a significant risk of chronic silicosis for workers exposed to inhaled crystalline silica over a working lifetime. Refer to the rule for more information regarding exposure limits and hazard prevention.



1st ISSUE	14/12/2017	
UPDATED	19/03/2018	2-44, 2-55.
	16/07/2018	Prop 65 0-2 @ 0-3.

Manitou BF S.A Limited liability company with a Board of Directors.
 Head office: 430, Rue de l'Aubinière - 44150 Ancenis - FRANCE
 Share capital: 39,548,949 euros
 857 802 508 RCS Nantes.
 Tel: +33 (0)2 40 09 10 11
 www.manitou.com

This manual is for information purposes only. Any reproduction, copy, representation, recording, transfer, distribution, or other, in part or in whole, in any format is prohibited. The plans, designs, views, commentaries and instructions, even the document organization that are found in this document, are the intellectual property of MANITOU BF. Any violation of the aforementioned may lead to civil and criminal prosecution. The logos as well as the visual identity of the company are the property of MANITOU BF and may not be used without express and formal authorization. All rights are reserved.

1 - OPERATING AND SAFETY INSTRUCTIONS

2 - DESCRIPTION

3 - MAINTENANCE

4 - OPTIONAL ATTACHMENTS FOR USE WITH THE RANGE

5 - LOAD CHARTS FOR INTERCHANGEABLE EQUIPMENT





1 - OPERATING AND SAFETY INSTRUCTIONS





REDUCE
04
MANITOU

ASSISTANCE | 23 SIMPLE TIPS

The Manitou Group wishes to assist you in reducing the consumption of the machines to help you reduce your carbon footprint.



Chose a machine with an appropriate power rating for your needs.



Switch off your engine after running at idle for more than 3 minutes.



Optimum engine efficiency is achieved at the maximum torque engine speed.



Preferably use a fan control and reversal system.



Favor "smart" electronically-managed transmissions.



Use the air-conditioning with windows and doors closed.



Preferably use LED headlights.



Adapt the type of tire to your environment.



Ensure that your tires are inflated to the correct pressure.



Check the parking brake adjustment.

Preferably use manufacturer-recommended attachments



Check the general condition of your trailer.



Adapt your maximum towable load.



Use the attachments that are suitable for your machine.



Check the hydraulic adjustment of your attachments.



Observe the maintenance periods.



Regularly clean the radiator, the air filter, etc.



Lubricate regularly.



Preferably buy through a manufacturer-approved dealer.



Favor OEM parts.



Study the manufacturers' maintenance contracts.



You can follow eco-driving courses.



Demand to know the consumption and emissions of the machines.



Calculate your consumption and emissions at reduce.manitou.com



1 - OPERATING AND SAFETY INSTRUCTIONS

<i>INSTRUCTIONS TO THE COMPANY MANAGER</i>	1-6
THE SITE	1-6
THE OPERATOR	1-6
THE TELEHANDLER	1-6
A - THE TRUCK'S SUITABILITY FOR THE JOB	1-6
B - ADAPTATION OF THE TELEHANDLER TO STANDARD ENVIRONMENTAL CONDITIONS	1-6
C - MODIFICATION OF THE TELEHANDLER	1-7
D - FRENCH ROAD TRAFFIC RULES	1-7
E - TELEHANDLER CAB PROTECTION	1-7
INSTRUCTIONS	1-8
MAINTENANCE	1-8
 <i>INSTRUCTIONS FOR THE OPERATOR</i>	 1-10
FOREWORD	1-10
GENERAL INSTRUCTIONS	1-10
A - INSTRUCTION MANUAL	1-10
B - AUTHORISATION FOR USE IN FRANCE	1-10
C - MAINTENANCE	1-10
D - MODIFICATION OF THE TELEHANDLER	1-10
E - LIFTING PEOPLE	1-11
OPERATING INSTRUCTIONS UNLADEN AND LADEN	1-11
A - BEFORE STARTING THE TELEHANDLER	1-11
B - DRIVER'S OPERATING INSTRUCTIONS	1-11
C - ENVIRONMENT	1-11
D - VISIBILITY	1-12
E - STARTING THE TELEHANDLER	1-13
F - DRIVING THE TELEHANDLER	1-13
G - STOPPING THE TELEHANDLER	1-14
H - DRIVING THE TELEHANDLER ON THE PUBLIC HIGHWAY	1-15
INSTRUCTIONS FOR HANDLING A LOAD	1-16
A - CHOICE OF ATTACHMENTS	1-16
B - WEIGHT OF LOAD AND CENTRE OF GRAVITY	1-16
C - LONGITUDINAL STABILITY LIMITER AND WARNING DEVICE	1-16
D - TRANSVERSE ATTITUDE OF THE TELEHANDLER	1-17
E - TAKING UP A LOAD ON THE GROUND	1-17
F - TAKING UP AND SETTING DOWN A HIGH LOAD ON TYRES	1-18
G - TAKING UP AND SETTING DOWN A HIGH LOAD ON STABILISERS	1-20
H - PICKING UP AND SETTING DOWN A SUSPENDED LOAD	1-22
I - TRAVELLING WITH A SUSPENDED LOAD	1-22
INSTRUCTIONS FOR USE AS A LOADER	1-23
A - LOADING	1-23
B - BACKFILLING	1-23
PLATFORM OPERATING INSTRUCTIONS	1-24
A - AUTHORISATION FOR USE	1-24
B - TELEHANDLER SUITABILITY FOR USE	1-24
C - PRECAUTIONS WHEN USING THE PLATFORM	1-24
D - USING THE PLATFORM	1-24
E - ENVIRONMENT	1-24
F - MAINTENANCE	1-25



INSTRUCTIONS FOR USING THE RADIO-CONTROL	1-26
HOW TO USE THE RADIO-CONTROL	1-26
PROTECTIVE DEVICES	1-26
<u>TELEHANDLER MAINTENANCE INSTRUCTIONS</u>	1-28
GENERAL INSTRUCTIONS	1-28
PLACING THE JIB SAFETY WEDGE	1-28
FITTING THE WEDGE	1-28
REMOVING THE WEDGE	1-28
MAINTENANCE	1-28
MAINTENANCE LOGBOOK	1-28
LUBRICANT AND FUEL LEVELS	1-29
HYDRAULIC SYSTEM	1-29
ELECTRICITY	1-29
WELDING	1-29
WASHING THE TELEHANDLER	1-29
TRANSPORTING THE TELEHANDLER	1-29
<u>IF THE TELEHANDLER IS NOT TO BE USED FOR A LONG TIME</u>	1-30
INTRODUCTION	1-30
PREPARING THE TELEHANDLER	1-30
DEF (Diesel Exhaust Fluid) TANK	1-30
PROTECTING THE ENGINE	1-30
PROTECTING THE TELEHANDLER	1-30
BRINGING THE TELEHANDLER BACK INTO SERVICE	1-31
<u>TELEHANDLER DISPOSAL</u>	1-32
RECYCLING OF MATERIALS	1-32
METALS	1-32
PLASTICS	1-32
RUBBER	1-32
GLASS	1-32
ENVIRONMENTAL PROTECTION	1-32
WORN OR DAMAGED PARTS	1-32
USED OIL	1-32
USED BATTERIES	1-32



INSTRUCTIONS TO THE COMPANY MANAGER

THE SITE

Proper management of telehandler's area of travel will reduce the risk of accidents:

- ground not unnecessarily uneven or obstructed,
- no excessive slopes,
- pedestrian traffic controlled, etc.

THE OPERATOR

- Only qualified, authorized personnel can use the telehandler. This authorization is given in writing by the appropriate person in the establishment with respect to the use of telehandlers and must be carried permanently by

⚠ IMPORTANT ⚠

Experience has shown that there are a number of inappropriate ways in which the telehandler might be used. Such foreseeable misuse, of which the main examples are listed below, is strictly forbidden.

-The foreseeable abnormal behaviour resulting from ordinary negligence, but not from any intentional misuse of the machinery.

- The reflex reactions of a person in the event of a malfunction, incident, fault, etc. during operation of the telehandler.

- Behaviour resulting from application of the "principle of least effort" when performing a task.

- For certain machines, the foreseeable behaviour of such persons as: apprentices, teenagers, handicapped persons, trainees tempted to drive a telehandler, operators tempted to operate the machine to win a bet, in competition or for their own personal experience.

The person in charge of the equipment must take these criteria into account when assessing whether or not a person will make a suitable driver.

THE TELEHANDLER

A - THE TRUCK'S SUITABILITY FOR THE JOB

- MANITOU has ensured that this telehandler is suitable for use under the standard operating conditions defined in

this operator's manual, with a **STATIC test coefficient of 1.33** and a **DYNAMIC test coefficient of 1**, as specified in harmonised standard **EN 1459** for variable reach trucks.

- Before commissioning, direct tests (in accordance with current legislation) of the telehandler is appropriate for the work to be

B - ADAPTATION OF THE TELEHANDLER TO STANDARD ENVIRONMENTAL CONDITIONS

- In addition to series equipment mounted on your telehandler, many options are available, such as: road lighting, stop lights, revolving light, reverse lights, reverse buzzer alarm, front light, rear light, light at the jib head, etc. (according to the telehandler model).

- The operator must take into account the operating conditions to specify the telehandler's signaling and lighting equipment. Contact your dealer.

- Take into account climatic and atmospheric conditions of the site of utilisation.

- Protection against frost (↩ 3 - MAINTENANCE: LUBRICANTS AND FUEL).
- Adaptation of lubricants (ask your dealer for information).
- Engine filtration (↩ 3 - MAINTENANCE: FILTER CARTRIDGES AND BELTS).

⚠ IMPORTANT ⚠

For operation under average climatic conditions, i.e.: between -15 °C and 35 °C, correct levels of lubricants in all the circuits are checked in production. For operation under more severe climatic conditions, before starting up, it is necessary to drain all the circuits, then ensure correct levels of lubricants using lubricants properly suited to the relevant ambient temperatures.

The same applies to the cooling liquid.

- Preventing fire risks associated with use in dusty and flammable conditions (e.g. straw, flour, sawdust, organic waste, etc.). - A telehandler operating in an area without fire extinguishing equipment must be equipped with an individual extinguisher. There are solutions, consult your dealer.

⚠ IMPORTANT ⚠

Your telehandler is designed for outdoor use under normal atmospheric conditions and indoor use in suitably aerated and ventilated premises. It is prohibited to use the telehandler in areas where there is a risk of fire or which are potentially explosive (e.g. refineries, fuel or gas depots, stores of flammable products, etc.).

For use in these areas, specific equipment is available (ask your dealer for information).

- Our trucks comply with Directive 2004/108/EC concerning electromagnetic compatibility (EMC), and with the corresponding harmonized standard EN 12895. Their proper operation is no longer guaranteed if they are used within areas in which the electromagnetic fields exceed the limit specified by that standard (10 V/m).

- Directive 2002/44/EC prohibits company managers from exposing their employees to excessive levels of vibration. There is no recognized code of measurement for comparing the machines of different manufacturers. The actual doses received can only therefore be measured under actual operating conditions at the user's premises.



- The following are some tips for minimizing these vibration doses:
 - Select the most suitable telehandler and attachment for the intended use.
 - Adapt the seat adjustment to the operator's weight (according to telehandler model) and maintain it in good condition, as well as the cab suspension. Inflate the tires in accordance with recommendations.
 - Ensure that the operators adapt their operating speed to suit the conditions on site.
 - As far as possible, arrange the site in such a way as to provide a flat running surface and remove obstacles and harmful potholes.

C - MODIFICATION OF THE TELEHANDLER

- For your safety and that of others, you must not change the structure and settings of the various components used in your telehandler (hydraulic pressure, calibrating limiters, engine speed, addition of extra equipment, addition of counterweight, unapproved attachments, alarm systems, etc.) yourself. In this event, the manufacturer cannot be held responsible.

D - FRENCH ROAD TRAFFIC RULES

(or see current legislation in other countries)

- Only one EC declaration of conformity is issued. It must be kept in a safe place.
- The road traffic rules of telehandlers are subject to the provisions of the highway code, according to the following categories:
 - Construction-type trucks (MT range): public works vehicle not predominantly for use on roads (point 6.9 of Article R311-1 of the French Highway Code). The truck must have a 25 disc displayed on the rear of the vehicle and an operating licence plate.
 - Agricultural-type trucks (MLT range) that are non-EC type approved tractors: (point 6.2 of Article R311/1 of the French Highway Code). The truck must be fitted with an operating licence plate.
 - Agricultural-type trucks (MLT range) that are EC type approved tractors: agricultural tractor type T1a (point 5.1.1 of Article R311/1 of the French Highway Code). The truck must be registered.

SPECIAL INSTRUCTION APPLYING TO "EC TRACTOR" TYPE-APPROVED TELEHANDLERS

- All EC tractor type-approved telehandlers are supplied with an "EC tractor" certificate complying with directive 2003/37/EC, to be retained by the owner, and a page of administrative details together with a CNIT number (national type approval code) for registration at the prefecture.
- The telehandler owner is responsible for carrying out the necessary procedures for obtaining the vehicle registration document within the time limit defined by the regulations. - The operator must hold a category B driver's licence, unless granted an exemption.
- The telehandler must be driven on the public highway in accordance with the instructions given in the manual supplied with the telehandler (Gross weight, Gross combination weight, towing load, axle loads, maximum speeds, etc. according to type/version). The operator must be in possession of the telehandler's registration document.

⚠ IMPORTANT ⚠

When towing a trailer or agricultural equipment, the travelling speed of the telehandler is limited to 25 km/h (15.5 mph). In this case, a "25" disc must be affixed to the rear of the convoy.

E - TELEHANDLER CAB PROTECTION

- All telehandlers comply with the requirements of ISO 3471 (wheel loader code) regarding cab rollover protection (ROPS) and ISO 3449 (Level II) regarding the protection of the cab against falling objects (FOPS).
- "EC TRACTOR" type-approved telehandlers comply, in addition, with Directive 79/622/EC (OECD Code 4) regarding cab rollover protection (ROPS).

⚠ IMPORTANT ⚠

Structural damage or overturning, modification, changes or poorly executed repairs can reduce the protective efficiency of the cab, resulting in cancellation of its compliance. Do not carry out any welding or drilling on the cab structure. Consult your dealer to determine the limits of this structure without cancelling its compliance.



INSTRUCTIONS

- The operator's manual must always be in good condition and kept in the place provided on the telehandler and in the language used by the operator.
- The operator's manual and any plates or stickers which are no longer legible or are damaged, must be replaced immediately.

MAINTENANCE

- Maintenance or repairs other than those detailed in part: 3 - MAINTENANCE must be carried out by qualified personnel (your dealer) and under the necessary safety conditions to maintain the health of the operator and any third party.

⚠ IMPORTANT ⚠

Your telehandler must be inspected periodically to ensure that it remains in compliance.

The frequency of this inspection is defined by current legislation in the country in which the telehandler is used.

- Example for France "The manager in charge of the establishment using a telehandler must open and maintain a maintenance log for each machine (order of 2 March 2004) and undergo a general periodic inspection every 6 months (order of 1 March 2004)".



Page intentionally left blank



INSTRUCTIONS FOR THE OPERATOR

FOREWORD

⚠ IMPORTANT ⚠

The risk of accident while using, servicing or repairing your telehandler can be reduced if you follow the safety instructions and preventive measures detailed in these instructions.

Failure to comply with the safety instructions and instructions for the use, repair or servicing of your telehandler may result in serious or even fatal accidents.

- Only the operations and manoeuvres described in these operator's manual must be performed. The manufacturer cannot predict all possible risky situations. Consequently, the safety instructions given in the operator's manual and on the telehandler itself are not exhaustive.
- At any time, as an operator, you must envisage, within reason, the possible risk to yourself, to others or to the telehandler itself when you use it.

⚠ IMPORTANT ⚠

In order to reduce or avoid any danger with a MANITOU-approved attachment, follow the instructions of paragraph:

4 - ADAPTABLE ATTACHMENTS AVAILABLE ON THE RANGE: INTRODUCTION.

GENERAL INSTRUCTIONS

A - INSTRUCTION MANUAL

- Read the operator's manual carefully.
- The operator's manual must always be in good condition and in the place provided for it on the telehandler. - You must report any plates and stickers which are no longer legible or which are damaged.

B - AUTHORISATION FOR USE IN FRANCE

(or see current legislation in other countries).

- Only qualified, authorized personnel can use the telehandler. This authorization is given in writing by the appropriate person in the establishment with respect to the use of telehandlers and must be carried permanently by the operator.
- The operator is not competent to authorise the driving of the telehandler by another person.

C - MAINTENANCE

- The operator must immediately advise his superior if his telehandler is not in good working order or does not comply with the safety notice.
- The operator is prohibited from carrying out any repairs or adjustments himself, unless he has been trained for this purpose. He must keep the telehandler properly cleaned if this is among his responsibilities.
- The operator must carry out daily maintenance (↖ 3 - MAINTENANCE: 10 HOUR - DAILY MAINTENANCE OR EVERY 10 HOURS OF SERVICE).
- The operator must ensure tyres are appropriate for the type of ground (↖ area of the contact surface of the tyres in the chapter: 2 - DESCRIPTION: TYRES). There are optional solutions, consult your dealer.
 - SAND tires.
 - FARM tires.
 - Snow chains.

⚠ IMPORTANT ⚠

Do not use the telehandler if the tyres are incorrectly inflated, damaged or excessively worn, because this could put your own safety or that of others at risk, or cause damage to the telehandler itself.

The fitting of foam inflated tyres is prohibited and is not guaranteed by the manufacturer, excepting prior authorisation.

- The operator is responsible for deciding and adjusting the frequency of cleaning needed to prevent the risk of fire ensuing from the build-up of flammable material(s). The operator should pay special attention to all the areas of the telehandler where these risk materials are likely to accumulate.

D - MODIFICATION OF THE TELEHANDLER

- For your safety and that of others, you must not change the structure and settings of the various components used in your telehandler (hydraulic pressure, calibrating limiters, engine speed, addition of extra equipment, addition of counterweight, unapproved attachments, alarm systems, etc.) yourself. In this event, the manufacturer cannot be held responsible.



E - LIFTING PEOPLE

- The use of working equipment and load lifting attachments to lift people is:
 - either forbidden
 - or authorised exceptionally and under certain conditions (Current regulations in the country in which the telehandler is used).
- The pictogram posted at the operator station reminds you that:
 - Left-hand column
 - It is forbidden to lift people, with any kind of attachment, using a non PLATFORM-fitted telehandler.
 - Right-hand column
 - With a PLATFORM-fitted telehandler, people can only be lifted using platforms designed by MANITOU for the purpose.
- MANITOU sells equipment specifically designed for lifting people (OPTION PLATFORM telehandler, contact your dealer).

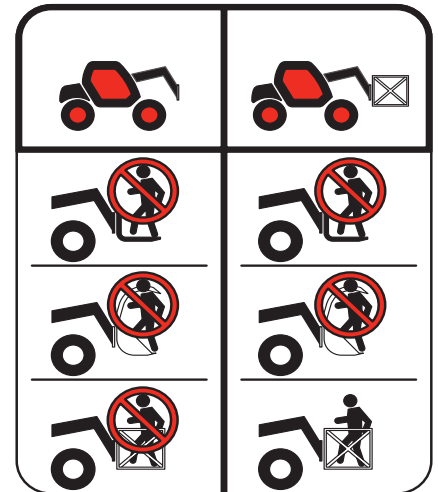

OPERATING INSTRUCTIONS UNLADEN AND LADEN

A - BEFORE STARTING THE TELEHANDLER

- Carry out daily maintenance (3 - MAINTENANCE: 10 HOUR - DAILY MAINTENANCE OR EVERY 10 HOURS OF SERVICE).
- Make sure that the driver's cab is clean, particularly the floor and floor mat. Check that no movable object may hinder the operation of the telehandler.
- Make sure the lights, indicators and windscreen wipers are working properly.
- Make sure the rear view mirrors are in good condition, clean and properly adjusted.
- Make sure the horn works.

B - DRIVER'S OPERATING INSTRUCTIONS

- Whatever his experience, the operator is advised to familiarize himself with the position and operation of all the controls and instruments before operating the telehandler.
- Wear clothes suited for driving the telehandler, avoid loose clothes.
- Make sure you have the appropriate protective equipment for the task to be performed.
- Prolonged exposure to high noise levels may cause hearing problems. It is recommended to wear ear muffs to protect against excessive noise.
- Always face the telehandler when getting into and leaving the driving seat and use the handle(s) provided for this purpose. Do not jump out of the seat to get down.
- Always pay attention when using the telehandler. Do not listen to the radio or music using headphones or earphones.
- Never operate the telehandler when hands or feet are wet or soiled with greasy substances.
- For increased comfort, adjust the seat to your requirements and adopt the correct position in the driver's cab.

⚠ IMPORTANT ⚠

Under no circumstances must the seat be adjusted while the telehandler is moving.

- The operator must always be in his normal position in the driver's cab. It is prohibited to have arms or legs, or generally any part of the body, protruding from the driver's cab of the telehandler.
- The safety belt must be worn and adjusted to the operator's size.
- The control units must never in any event be used for any other than their intended purposes (e.g. climbing onto or down from the telehandler, portmanteau, etc.).
- If the control components are fitted with a forced operation (lever lock) device, it is forbidden to leave the cab without first putting these controls in neutral.
- It is prohibited to carry passengers either on the telehandler or in the driver's cab.

C - ENVIRONMENT

- Comply with site safety regulations.
- If you have to use the telehandler in a dark area or at night, make sure it is equipped with working lights.
- During handling operations, make sure that no one is in the way of the telehandler and its load.
- Do not allow anybody to come near the working area of the telehandler or pass beneath an elevated load.
- When using the telehandler on a transverse slope, before lifting the jib, follow the instructions given in the paragraph: INSTRUCTIONS FOR HANDLING A LOAD: D - TRANSVERSE ATTITUDE OF THE TELEHANDLER.



- Travelling on a longitudinal slope:
 - Drive and brake gently.

- Moving without load: forks or attachment facing downhill.

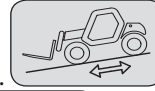

- Moving with load: Forks or attachment facing uphill.

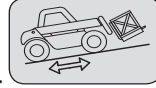

- Take into account the telehandler's dimensions and its load before trying to negotiate a narrow or low passageway.
- Never move onto a loading platform without having first checked:
 - That it is suitably positioned and made fast.
 - That the unit to which it is connected (wagon, lorry, etc.) will not shift.
 - That this platform is prescribed for the total weight of the telehandler to be loaded.
 - That this platform is prescribed for the size of the telehandler.
- Never move onto a foot bridge, floor or freight lift, without being certain that they are prescribed for the weight and size of the telehandler to be loaded and without having checked that they are in sound working order.
- Be careful in the area of loading bays, trenches, scaffolding, soft ground and manholes.
- Make sure the ground is stable and firm under the wheels and/or stabilizers before lifting or removing the load. If necessary, add sufficient wedging under the stabilizers.
- Make sure that the scaffolding, loading platform, pilings or ground is capable of bearing the load.
- Never stack loads on uneven ground, they may tip over.

⚠ IMPORTANT ⚠

If the load or the attachment must remain above a structure for a long time, there is the risk that it will rest on the structure because of the boom descending owing to the oil in the cylinders cooling down.

To eliminate this risk:

- *Regularly check the distance between the load or the attachment and the structure and readjust this if necessary.*
- *If possible, use the telehandler with the oil temperature as close as possible to ambient temperature.*

- When working near aerial lines, ensure that the safety distance is sufficient between the working area of the telehandler and the aerial line.

⚠ IMPORTANT ⚠

You must consult your local electrical agency.

You could be electrocuted or seriously injured if you operate or park the telehandler too close to power cables.

In the event of high winds, do not carry out handling work that jeopardises the stability of the telehandler and its load, particularly if the load catches the wind badly. -

Prevent fire risks associated with use in dusty and flammable conditions (e.g. straw, flour, sawdust, organic waste, etc.).

D - VISIBILITY

- The safety of people within the telehandler's working area, as well as that of the telehandler itself and the operator are depend on good operator visibility of the telehandler's immediate vicinity in all situations and at all times.
- This telehandler has been designed to allow good operator visibility (direct or indirect by means of rear-view mirrors) of the immediate vicinity of the telehandler while travelling with no load and with the jib in the transport position.
- Special precautions must be taken if the size of the load restricts visibility towards the front:
 - moving in reverse,
 - site layout,
 - assisted by a person directing the manoeuvre (while standing outside the truck's area of travel), making sure to keep this person clearly in view at all times,
 - in any case, avoid reversing over long distances.
- Certain special accessories may require the truck to travel with the jib in the raised position. In such cases, visibility on the right hand side is restricted, and special precautions must be taken:
 - site layout,
 - assisted by a person directing the manoeuvre (while standing outside the truck's area of travel).
 - replacement of a suspended load by a load on a pallet.
- If visibility of your road is inadequate, ask someone to assist by directing the manoeuvre (while standing outside the truck's area of travel), making sure to keep this person clearly in view at all times.
- Keep all components affecting visibility in a clean, properly adjusted state and in good working order (e.g. windscreens, windows, windscreen wipers, windscreen washers, driving and work lights, rear-view mirrors).



E - STARTING THE TELEHANDLER

SAFETY INSTRUCTIONS

⚠ IMPORTANT ⚠

The telehandler must only be started up or manoeuvred when the operator is sitting in the driver's cab, with his seat belt adjusted and fastened.

- Never try to start the telehandler by pushing or hauling it. Such an operation may cause severe damage to the transmission. If necessary, towing requires the transmission to be put in neutral (⚠ 3 - MAINTENANCE: OCCASIONAL OPERATION).
- If using an emergency battery for start-up, use a battery with the same characteristics and respect battery polarity when connecting it. Connect at first the positive terminals before the negative terminals.

⚠ IMPORTANT ⚠

*Failure to respect polarity between batteries can cause serious damage to the electrical circuit.
The electrolyte in the battery may produce an explosive gas. Avoid flames and generation of sparks close to the batteries.
Never disconnect a battery while it is charging.*

INSTRUCTIONS

- Check the closing and locking of the hood(s).
- Check that the cab door is closed.
- Check that the forward/reverse selector is in neutral, and that the parking brake is engaged.
- Turn the ignition key to the position I to activate the electrical and pre-heating system.
- Check the fuel level on the indicator.

⚠ IMPORTANT ⚠

It is forbidden to press the accelerator pedal when starting the engine.

- Turn the ignition key fully, the engine should then start. Release the ignition key and let the engine run at idle.
- Do not engage the starter motor for more than 15 seconds and carry out the preheating between unsuccessful attempts.
- Make sure all the signal lights on the control instrument panel are off.
- Check all control instruments when the engine is warm and at regular intervals during use, so as to quickly detect any faults and to be able to correct them without any delay.
- If an instrument does not show the correct display, stop the engine and immediately carry out the necessary operations.

F - DRIVING THE TELEHANDLER

SAFETY INSTRUCTIONS

⚠ IMPORTANT ⚠

Operators' attention is drawn to the risks involved in using the forklift, in particular:

- Risk of losing control.

- Risk of losing lateral and frontal stability of the forklift.

The operator must remain in control of the telehandler. In the event of the telehandler overturning, do not try to leave the cabin during the incident.

YOUR BEST PROTECTION IS TO STAY FASTENED IN THE CABIN.

- Observe the company's traffic regulations or, by default, the public highway code.
- Do not carry out operations which exceed the capacities of your telehandler or attachments.
- Always drive the telehandler with the forks or attachment to the transport position, i.e. at 300 mm (11.8 in) from the ground, the jib retracted and the carriage sloping backwards.
- Only carry loads which are balanced and properly anchored to avoid any risk of a load falling off.
- Ensure that pallets, crates, etc, are in good condition and suitable for the load to be lifted.
- Familiarise yourself with the telehandler on the terrain where it will be used.
- Ensure that the service brakes are working properly.
- The loaded telehandler must not travel at speeds in excess of 5 km/h (3.1 mph).
- Drive smoothly at an appropriate speed for the operating conditions (land configuration, load on the telehandler).
- Do not use the hydraulic jib controls when the telehandler is moving.
- Never change the steering mode whilst driving.
- Do not manoeuvre the telehandler with the jib in the raised position unless under exceptional circumstances and then with extreme caution, at very low speed and using gentle braking. Ensure that visibility is adequate.
- Take bends slowly.
- In all circumstances make sure you are in control of your speed.
- On damp, slippery or uneven terrain, drive slowly.
- Brake gently, never abruptly.
- Only use the telehandler's forward/reverse selector from a stationary position and never do so abruptly.
- Do not drive with your foot on the brake pedal.



- Always remember that hydrostatic type steering is extremely sensitive to movement of the steering wheel, so turn it gently and not jerkily.
- Never leave the engine on when the telehandler is unattended.
- Do not leave the cab when the telehandler has a raised load.
- Look where you are going and always make sure you have good visibility along the route.
- Use the rear-view mirrors frequently.
- Drive round obstacles.
- Never drive on the edge of a ditch or steep slope.
- It is dangerous to use two telehandlers simultaneously to handle heavy or bulky loads, since this operation requires particular precautions to be taken. It must only be used exceptionally and after risk analysis.
- The ignition switch has an emergency stop mechanism in case of an operating anomaly occurring in the case of telehandlers not fitted with a punch-operated cut-out.

INSTRUCTIONS

- Always drive the telehandler with the forks or attachment to the transport position, i.e. at 300 mm (11.8 in) from the ground, the jib retracted and the carriage sloping backwards.
- For telehandlers with gearboxes, use the recommended gear (↩ 2 - DESCRIPTION: CONTROL AND COMMAND INSTRUMENTS).
- Select the steering mode appropriate for the use and/or working conditions (↩ 2 - DESCRIPTION: CONTROL AND COMMAND INSTRUMENTS) (according to model of telehandler).
- Release the hand brake.
- Shift the forward/reverse selector to the selected direction of travel and accelerate gradually until the telehandler moves off.

⚠ IMPORTANT ⚠

- Starting and driving a telehandler on a slope can present a very real danger.
The telehandler being parked or stopped, scrupulously follow the following instructions for moving*
- Press the service brake pedal.
 - Engage 1st or 2nd gear and select forward or reverse.
 - Check that there is nothing and no-one obstructing the telehandler's path.
 - Release the service brake pedal and increase the engine revs.
- The risk is increased if the telehandler is laden or towing a trailer, requiring extreme vigilance.*

G - STOPPING THE TELEHANDLER

SAFETY INSTRUCTIONS

- Never leave the ignition key in the telehandler during the operator's absence.
- When the telehandler is stationary, or if the operator has to leave his cab (even for a moment), place the forks or attachment on the ground, apply the parking brake and place the forward/reverse selector in neutral.
- Make sure that the telehandler is not stopped in any position that will interfere with the traffic flow and at less than one meter from the track of a railway.
- In the event of prolonged parking on a site, protect the telehandler from bad weather, particularly from frost (check the level of antifreeze), close and lock all the telehandler accesses (doors, windows, cowls, etc.).

INSTRUCTIONS

- Park the telehandler on flat ground or on an incline lower than 15 %.
- Set the forward/reverse selector to neutral.
- Apply the parking brake.
- For telehandlers with gearboxes, place the gear lever in neutral.
- Fully retract the jib.
- Lower the forks or attachment to rest on the ground.
- When using an attachment with a grab or jaws, or a bucket with hydraulic opening, close the attachment fully.
- Before stopping the telehandler after a long working period, leave the engine idling for a few moments, to allow the coolant liquid and oil to lower the temperature of the engine and transmission. Do not forget this precaution, in the event of frequent stops or warm stalling of the engine, or else the temperature of certain parts will rise significantly due to the stopping of the cooling system, with the risk of badly damaging such parts.
- Stop the engine with the ignition switch.
- Remove the ignition key.
- Lock all access to the telehandler (doors, windows, cowls, etc).



H - DRIVING THE TELEHANDLER ON THE PUBLIC HIGHWAY

(or see current legislation in other countries)

FRENCH ROAD TRAFFIC RULES

- The driving of non EC type-approved tractors on the public highway is subject to the provisions of the highway code relating to special machines, defined in article R311-1 of the highway code, in category B of the Equipment Order of 20 November 1969 that determines the procedures applicable to special machines. The telehandler must be fitted with a licence plate.
- The driving of EC type-approved tractors on the public highway is subject to the provisions of the highway code regarding agricultural tractors, defined in article R311-1 of the highway code. The telehandler must be registered.
- The telehandler must be driven on the public highway in accordance with the instructions given in the manual supplied with the telehandler (Gross weight, Gross combination weight, towing load, axle loads, maximum speeds, etc. according to type/version). The operator must be in possession of the telehandler's registration document.
- The operator must hold an HGV licence, unless granted an exemption.
- When towing a trailer or agricultural equipment, the travelling speed of the telehandler is limited to 25 km/h (15.5 mph). In this case, a "25" disc must be affixed to the rear of the convoy. When driving with a trailer, the fact of not engaging 4th gear will ensure compliance with the towing speed limit (max. 25 km/h-15.5 mph). On "POWERSHIFT" models, as 3rd gear is slower than on other models, it is preferable to use 5th gear and disable automatic upshifting to 6th gear (◀ 2 - DESCRIPTION: CONTROL AND COMMAND INSTRUMENTS).

SAFETY INSTRUCTIONS

- Operators driving on the public highway must comply with current highway code legislation.
- The telehandler must comply with current road legislation. If necessary, there are optional solutions. Contact your dealer.

INSTRUCTIONS

- Make sure the revolving light is in place, switch it on and verify its operation.
- Make sure the lights, indicators and windscreen wipers are working properly.
- Switch off the working headlights if the telehandler is fitted with them.
- Select the steering mode "HIGHWAY TRAFFIC" (according to model of telehandler) (◀ 2 - DESCRIPTION: CONTROL AND COMMAND INSTRUMENTS).
- Fully retract the jib and set the attachment approximately 300 mm (11.8 in) off the ground.
- Place the roll corrector in the central position, i.e. the transverse axis of the axles parallel to the chassis (as model of telehandler).
- Fully raise the stabilizers and turn the blocks inwards (according to model of telehandler).

▲ IMPORTANT ▲

Never move in neutral (forward/reverse selector or gear lever in neutral or transmission cut-off button pressed) to preserve the telehandler engine brake. Failure to respect this instruction on a slope will lead to excessive speed which may make the telehandler uncontrollable (steering, brakes) and cause serious mechanical damage.

DRIVING THE TELEHANDLER WITH A FRONT-MOUNTED ATTACHMENT

- You must comply with current regulations in your country, covering the possibility of driving on the public highway with a front-mounted attachment on your telehandler.
- If road legislation in your country authorizes circulation with a front-mounted attachment, you must at least:
 - Protect and report any sharp and/or dangerous edges on the attachment (◀ 4 - ADAPTABLE ATTACHMENTS AVAILABLE ON THE RANGE: ATTACHMENT SHIELDS).
 - The attachment must not be loaded.
 - Make sure that the attachment does not mask the lighting range of the forward lights.
 - Make sure that current legislation in your country does not require other obligations.

OPERATING THE TELEHANDLER WITH A TRAILER

- For using a trailer, observe the regulations in force in your country (maximum travel speed, braking, maximum weight of trailer, etc.).
- Do not forget to connect the trailer's electrical equipment to that of the telehandler.
- The trailer's braking system must comply with current legislation.
- If pulling a trailer with assisted braking, the tractor telehandler must be equipped with a trailer braking mechanism. In this case, do not forget to connect the trailer braking equipment to the telehandler.
- The vertical force on the towing hook must not exceed the maximum authorised by the manufacturer (consult the manufacturer's plate on your telehandler).
- The authorised gross vehicle weight must not exceed the maximum weight authorised by the manufacturer (◀ 2 - DESCRIPTION: CHARACTERISTICS).

IF NECESSARY, CONSULT YOUR DEALER.

INSTRUCTIONS FOR HANDLING A LOAD

A - CHOICE OF ATTACHMENTS

- Only attachments approved by MANITOU can be used on its telehandlers.
- Make sure the attachment is appropriate for the work to be done (4 - ADAPTABLE ATTACHMENTS AVAILABLE ON THE RANGE).
- If the telehandler is equipped with the single side-shift carriage OPTION (TSDL), use only the authorised attachments (4 - ADAPTABLE ATTACHMENTS AVAILABLE ON THE RANGE).
- Make sure the attachment is correctly installed and locked onto the telehandler carriage.
- Make sure that your telehandler attachments work properly.
- Comply with the load chart limits for the telehandler for the attachment used.
- Do not exceed the rated capacity of the attachment.
- Never lift a load in a sling without the attachment provided for the purpose, as there is a risk of the sling slipping (INSTRUCTIONS FOR HANDLING A LOAD: H - TAKING UP AND LAYING DOWN A SUSPENDED LOAD).
- Do not handle loads that are hung directly from the forks with straps (e.g.: big bags), as there is a risk that the straps will shear against the sharp edges. Use an attachment designed for this purpose.

B - WEIGHT OF LOAD AND CENTRE OF GRAVITY

- Before taking up a load, you must know its mass and its centre of gravity.
- The load chart for your telehandler is valid for a load in which the longitudinal position of the centre of gravity is 500 mm (19.6 in) from the base of the forks (fig. B1). For a higher centre of gravity, contact your dealer.
- For irregular loads, determine the transverse centre of gravity before any movement (fig. B2) and set it in the longitudinal axis of the telehandler.

⚠ IMPORTANT ⚠

It is forbidden to handle a load heavier than the effective capacity specified on the truck load chart. For loads with a moving centre of gravity (e.g. liquids), take account of the variations in the centre of gravity in order to determine the load to be handled and be extra vigilant and careful to limit these variations as far as possible.

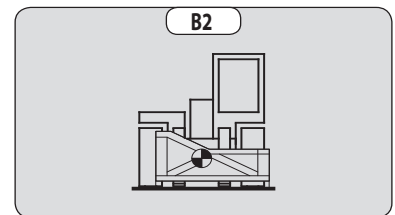
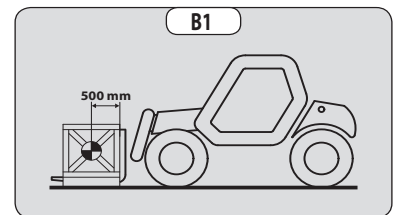

C - LONGITUDINAL STABILITY LIMITER AND WARNING DEVICE

This device gives an indication of the longitudinal stability of the telehandler, and limits hydraulic movements in order to ensure this stability, at least under the following operating conditions:

- when the telehandler is at a standstill,
- when the telehandler is on firm, stable and consolidated ground,
- when the telehandler is performing handling and placing operations.
- Move the boom very carefully when approaching the authorised load limit (2 - DESCRIPTION: CONTROL AND COMMAND INSTRUMENTS).
- Always watch this device during handling operations.
- In the event that "AGGRAVATING" hydraulic movements are cut-off, only perform de-aggravating hydraulic movements in the following order (fig. C): if necessary, raise the jib (1), retract the jib as far as possible (2) and lower the jib (3) to set down the load.

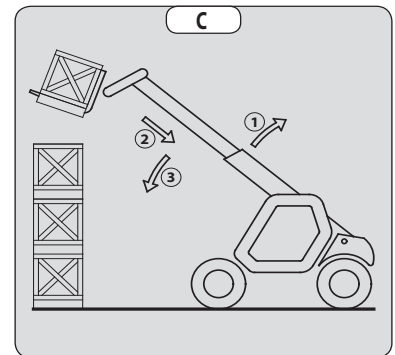

⚠ IMPORTANT ⚠

The instrument reading may be erroneous when the steering is at its maximum limit or the rear axle oscillated to its limit. Before lifting a load, make sure that the telehandler is not in either of these situations.

C1/C2 - LONGITUDINAL STABILITY INDICATOR

Always watch this device during handling operations.

- Letters and angle indicator (fig. C1) allow to read and respect load capacities of the lifttruck according to the load chart (see: 2 - DESCRIPTION: DIMENSION AND LOADCHART).
- When the device is in limit stability, it is forbidden to perform so-called «AGGRAVATING» movements, these being:
 - A - Extending the jib.
 - B - Lowering the jib.
- Perform movements to relieve aggravation in the following order (fig. C2): if necessary, raise the jib (1), retract the jib as far as possible (2) and lower the jib (3) to release the load.

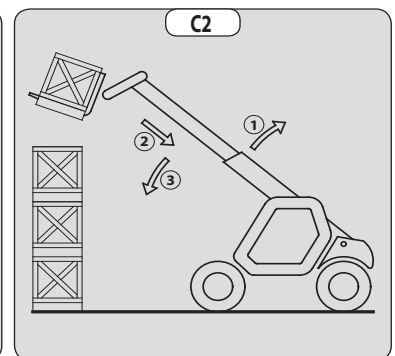
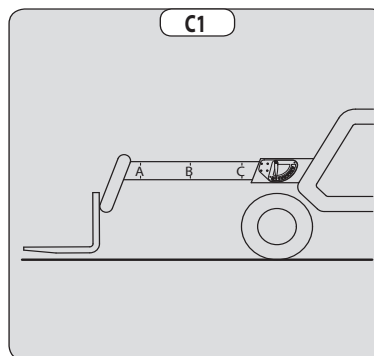

D - TRANSVERSE ATTITUDE OF THE TELEHANDLER

Depending on the model of telehandler

The transverse attitude is the transverse slope of the chassis with respect to the horizontal.

Raising the jib reduces the telehandler's lateral stability. The transverse attitude must be set with the jib in down position as follows:

1 - TELEHANDLER WITHOUT ROLL CORRECTOR USED ON TYRES

- Position the telehandler so that the bubble in the level is between the two lines (↖ 2 - DESCRIPTION: CONTROL AND COMMAND INSTRUMENTS).

2 - TELEHANDLER WITH ROLL CORRECTOR USED ON TYRES

- Correct the roll using the hydraulic control and check horizontality with the spirit level. The bubble in the level must be between the two lines (↖ 2 - DESCRIPTION: CONTROL AND COMMAND INSTRUMENTS).

3 - TELEHANDLER USED ON STABILIZERS

- Set the two stabilizers on the ground and raise the two front wheels of the telehandler (fig. D1).
- Correct the roll using the stabilisers (fig. D2) and check horizontality with the spirit level. The bubble of the level must be between the two lines (↖ 2 - DESCRIPTION: CONTROL AND COMMAND INSTRUMENTS). In this position, the two front wheels must be off the ground.

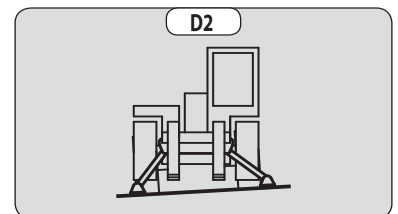
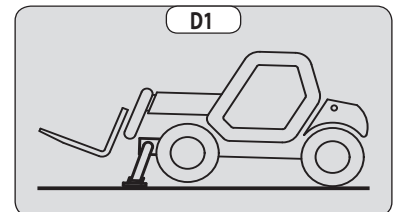

E - TAKING UP A LOAD ON THE GROUND

- Approach the telehandler perpendicular to the load, with the jib retracted and the forks in a horizontal position (fig. E1).
- Adjust the fork spread and centering relative to the load to ensure stability (fig. E2) (optional solutions exist, consult your dealer).
- Never lift a load with a single fork.

⚠ IMPORTANT ⚠

Beware of the risks of trapping or squashing limbs when manually adjusting the forks.

- Move the telehandler forward slowly (1) and insert the forks under the load as far as they will go (fig. E3). If necessary, slightly lift the jib (2) while taking up the load. - Bring the load into the transport position.
- Tilt the load far enough backwards to ensure stability (loss of load on braking or going downhill).

FOR A NON-PALLETIZED LOAD

- Tilt the carriage (1) forwards and move the telehandler slowly forwards (2), to insert the fork under the load (fig. E4) (block the load if necessary).
- Continue to move the telehandler forwards (2) tilting the carriage (3) (fig. E4) backwards to position the load on the forks and check the load's longitudinal and lateral stability.

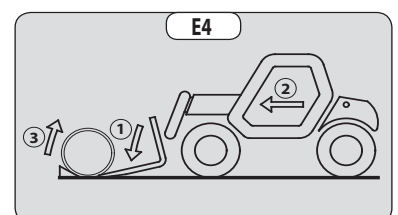
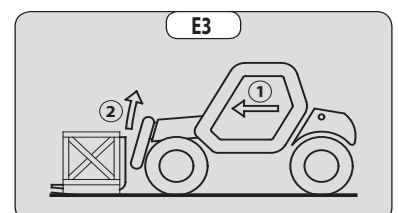
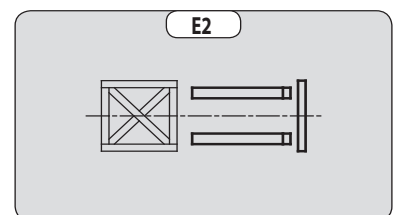
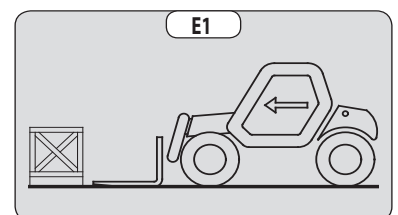

F - TAKING UP AND SETTING DOWN A HIGH LOAD ON TYRES

⚠ IMPORTANT ⚠

You must not raise the jib if you have not checked the transverse attitude of the telehandler. (INSTRUCTIONS FOR HANDLING A LOAD: D - TRANSVERSE ATTITUDE OF THE TELEHANDLER).

REMINDER: Make sure that the following operations can be performed with good visibility (OPERATION INSTRUCTIONS UNLADEN AND LADEN: D - VISIBILITY).

TAKING UP A HIGH LOAD ON TYRES

- Ensure that the forks will easily pass under the load.
- Lift and extend the jib (1) (2) until the forks are level with the load, moving the telehandler (3) forward if necessary (fig. F1), moving very slowly and carefully.
- Always remember to keep the distance necessary for inserting the forks under the load, between the stack and the telehandler (fig. F1) and use the shortest possible length of jib.
- Insert the forks under the load as far as they will go by alternately extending and lowering the jib (1) or, if necessary, moving the telehandler forward (2) (fig. F2). Apply the handbrake and place the forward/reverse selector in neutral.
- Slightly raise the load (1) and tilt the carriage (2) backwards to stabilize the load (fig. F3).
- Tilt the load sufficiently backwards to ensure its stability.
 - Monitor the longitudinal stability limiter and warning device (INSTRUCTIONS FOR HANDLING A LOAD: C - LONGITUDINAL STABILITY LIMITER AND WARNING DEVICE). If it is overloaded, set the load back down in the place from which it was taken.
- If possible lower the load without shifting the telehandler. Lift the jib (1) to release the load, retract (2) and lower the jib (3) to bring the load into the transport position (fig. F4).
- If this is not possible, back up the telehandler (1), manoeuvring very gently and carefully to release the load. Retract (2) and lower the jib (3) to bring the load into the transport position (fig. F5).

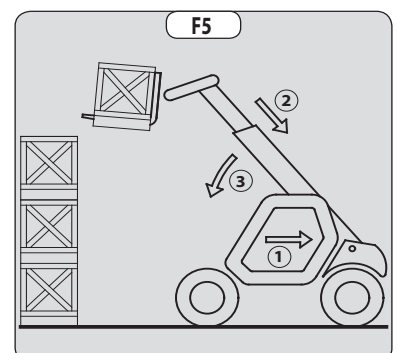
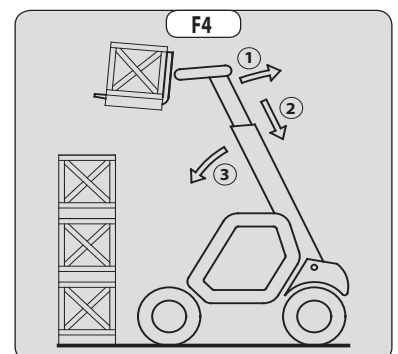
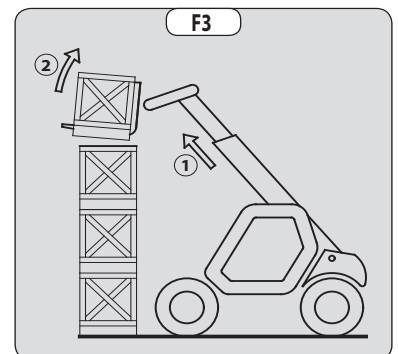
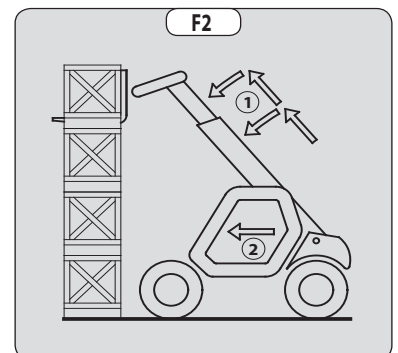
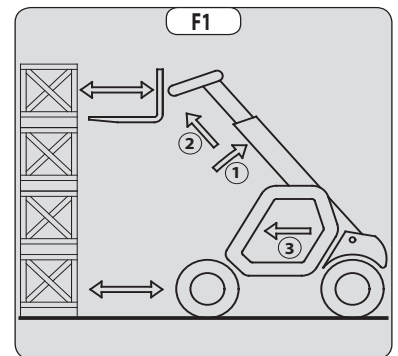

SETTING DOWN A HIGH LOAD ON TYRES

- Approach the load in the transport position in front of the stack (fig. F6).
- Apply the parking brake and place the forward/reverse selector in neutral.
- Raise and extend the jib (1) (2) until the load is above the stack, while monitoring the longitudinal stability limiter and warning device (⚠ IINSTRUCTIONS FOR HANDLING A LOAD: C - LONGITUDINAL STABILITY LIMITER AND WARNING DEVICE). If necessary, move the telehandler (3) forward (fig. F7), driving very slowly and carefully. - Place the load in a horizontal position and lay it down on the pile by lowering and retracting the jib (1) (2) in order to position the load correctly (fig. F8).
- If possible, release the fork by alternately retracting and raising the jib (1) (fig. F9). Then set the forks into transport position.
- If this is not possible, reverse the telehandler (1), manoeuvring very slowly and carefully to release the forks (fig. F10). Then set them into transport position.

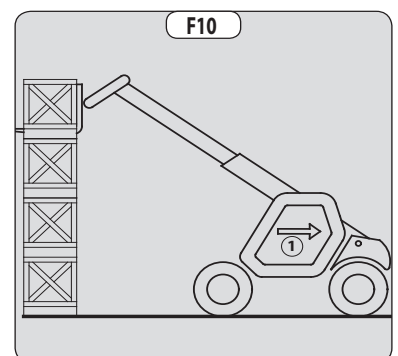
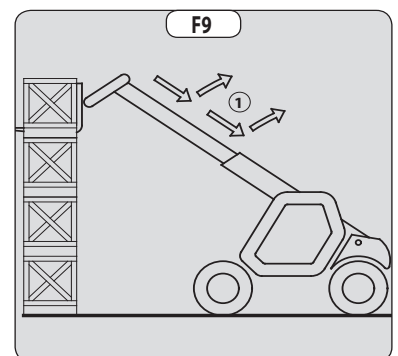
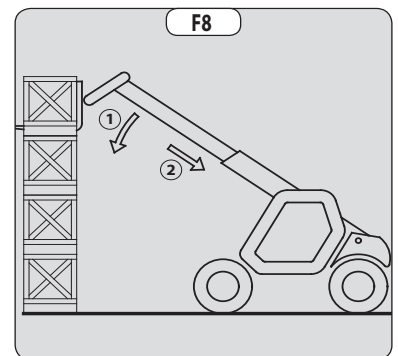
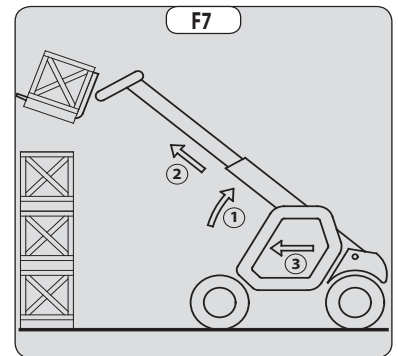
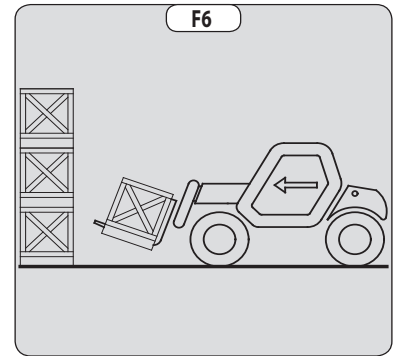

G - TAKING UP AND SETTING DOWN A HIGH LOAD ON STABILISERS

Depending on the model of telehandler

⚠ IMPORTANT ⚠

You must not raise the jib if you have not checked the transverse attitude of the telehandler (INSTRUCTIONS FOR HANDLING A LOAD: D - TRANSVERSE ATTITUDE OF THE TELEHANDLER).

REMINDER: Make sure that the following operations can be performed with good visibility (OPERATION INSTRUCTIONS UNLADEN AND LADEN: D - VISIBILITY).

The stabilisers are used to optimise the telehandler's lifting performance (2 - DESCRIPTION: CONTROL AND COMMAND INSTRUMENTS).

POSITIONING THE STABILISERS WITH THE FORKS IN TRANSPORT POSITION (UNLADEN AND LADEN)

- Set the forks in transport position in front of the elevation.
- Stay far enough away to have room for the jib to be raised.
- Apply the parking brake and place the forward/reverse selector in neutral.
- Set the two stabilizers on the ground and lift the two front wheels of the telehandler (fig. G1), while maintaining its transverse stability.

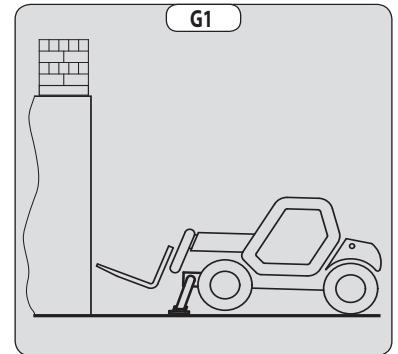

RAISING THE STABILISERS WITH THE FORKS IN TRANSPORT POSITION (UNLADEN AND LADEN)

- Raise both stabilizers fully and at the same time.

LOWERING OF STABILISERS WITH JIB UP (UNLADEN AND LADEN)

⚠ IMPORTANT ⚠

This operation must be exceptional and performed with great care.

- Raise the jib and retract the telescopes completely.
- Set the telehandler in position in front of the elevation (fig. G2) moving very slowly and carefully.
- Apply the parking brake and place the forward/reverse selector in neutral.
- Move the stabilizers very slowly and gradually as soon as they are close to the ground or in contact with it.
- Lower the two stabilizers and lift the two front wheels of the telehandler (fig. G3). During this operation, transverse attitude must be permanently maintained: the bubble in the level must be kept between the two lines.

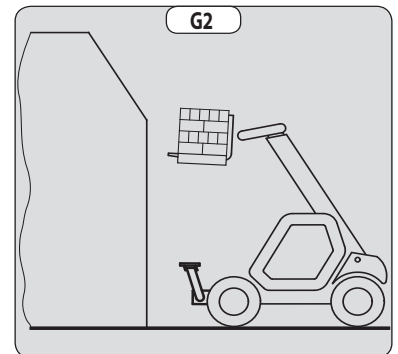

SETTING THE STABILISERS WITH THE BOOM UP (UNLADEN AND LADEN)

⚠ IMPORTANT ⚠

This operation must be exceptional and performed with great care.

- Keep the jib up and retract the telescopes completely (fig. G3).
- Move the stabilizers very slowly and gradually as soon as they are in contact with the ground and when they leave the ground. During this operation, the transverse attitude must be permanently maintained: the bubble in the level must be kept between the two lines.
- Raise both stabilizers completely.
- Release the parking brake and reverse the telehandler (1) very slowly and carefully, to release it and lower the forks (2) into transport position (fig. G4).

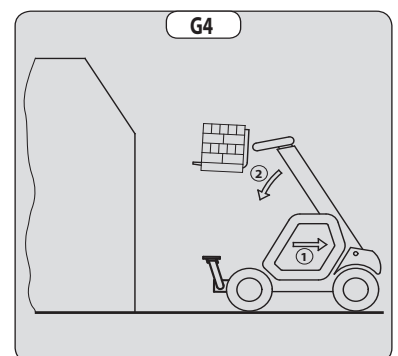
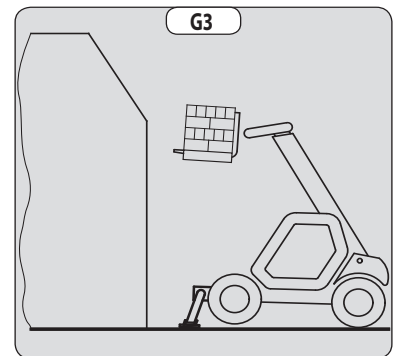

TAKING UP A HIGH LOAD ON STABILISERS

- Ensure that the forks will easily pass under the load.
- Check the position of the telehandler with respect to the load and make a test run, if necessary, without taking the load.
- Raise and extend the jib (1) (2) until the forks are at the level of the load (fig. G5).
- Insert the forks under the load as far as they will go by alternately extending and lowering the jib (1) (fig. G6).
- Lift the load slightly (1) and tilt the carriage (2) backwards to stabilise the load (fig. G7).
- Monitor the longitudinal stability limiter and warning device (⚠ INSTRUCTIONS FOR HANDLING A LOAD: C - LONGITUDINAL STABILITY LIMITER AND WARNING DEVICE). If it is overloaded, set the load back down in the place from which it was taken.
- If possible lower the load without moving the telehandler. Raise the jib (1) to release the load, retract (2) and lower the jib (3) to set the load into transport position (fig. G8).

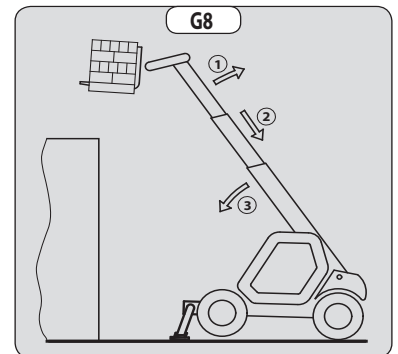
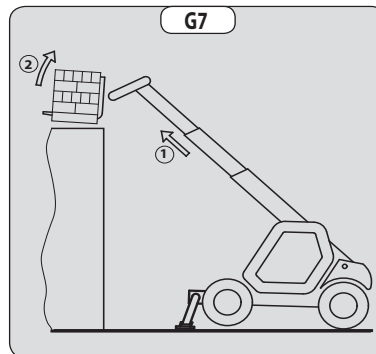
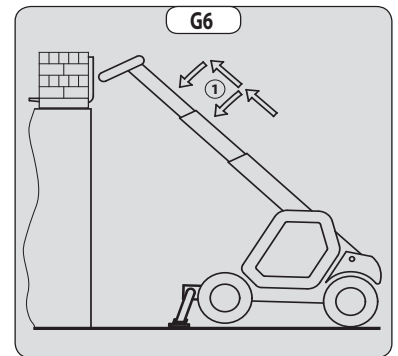
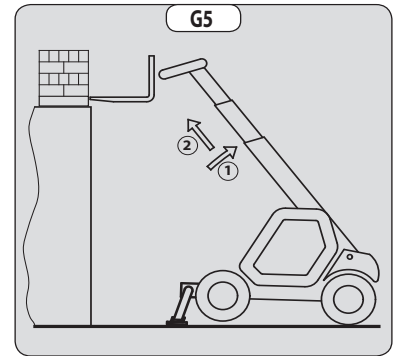

SETTING DOWN A HIGH LOAD ON STABILISERS

- Raise and extend the jib (1) (2) until the load is above the elevation (fig. G9), while monitoring the longitudinal stability limiter and warning device (⚠ INSTRUCTIONS FOR HANDLING A LOAD: C - LONGITUDINAL STABILITY LIMITER AND WARNING DEVICE).
- Position the load horizontally and release it by lowering and retracting the jib (1) (2) to position the load correctly (fig. G10).
- Free the forks by alternating retracting and raising the jib (3) (fig. G11).
- If possible, set the jib in transport position without moving the telehandler.

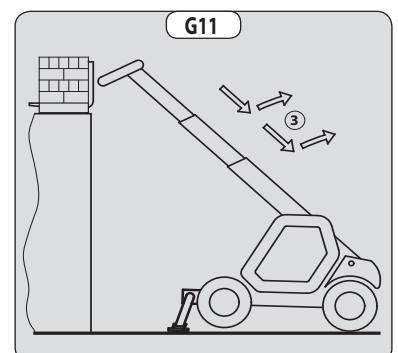
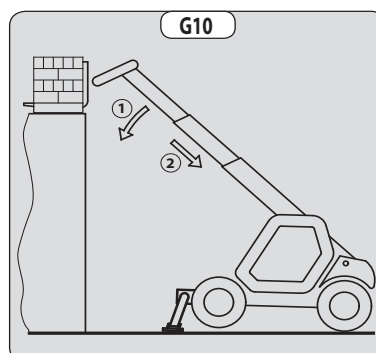
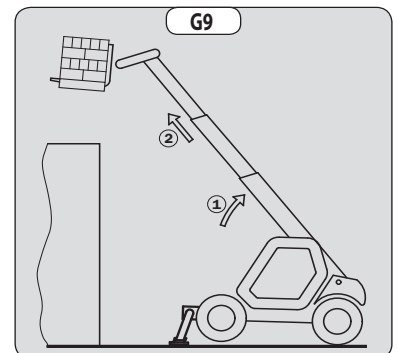



H - PICKING UP AND SETTING DOWN A SUSPENDED LOAD

⚠ IMPORTANT ⚠

*Failure to follow the above instructions may lead the telehandler to lose stability and overturn.
MUST be used with a telehandler equipped with an operational hydraulic movement cut-out device.*

CONDITIONS OF USE

- The length of the sling or the chain shall be as short as possible to limit swinging of the load.
- Lift the load vertically along its axis, never by pulling sideways or lengthways.

HANDLING WITHOUT MOVING THE TELEHANDLER

- Whether on stabilisers or on tyres, the lateral attitude must not exceed 1 % and the longitudinal attitude must not exceed 5%, the bubble of the level must be held at "0".
- Ensure that the wind speed is not higher than 10 m/s (32.8 ft/s).
- Ensure that there is no one between the load and the telehandler.

I - TRAVELLING WITH A SUSPENDED LOAD

- Before moving, inspect the terrain in order to avoid excessive slopes and cross-falls, bumps and potholes, or soft ground.
- Ensure that the wind speed is not higher than 36 km/h (22.3 mph).
- The telehandler must not travel at more than 0.4 m/s (1.3 ft/s) (1.5 km/h-0.9 mph, i.e., one quarter walking speed).
- Drive and stop the telehandler gently and smoothly to minimise swinging of the load.
- Carry the load a few centimetres above the ground (max. 30 cm - 11.8 in) the shortest possible jib length. Do not exceed the offset indicated on the load chart. If the load begins to swing excessively, do not hesitate to stop and lower the jib to set down the load.
- Before moving the telehandler check the longitudinal stability limiter and warning device (⚠ 2 - DESCRIPTION: INSTRUMENTS AND CONTROLS), only the green LEDs and possibly the yellow LEDs should be lit.
- During transport, the telehandler operator must be assisted by a person on the ground (standing a minimum of 3 m (98.4 ft) from the load), who will limit swinging of the load using a bar or a rope. Ensure that this person is always clearly in view. - The lateral attitude must not exceed 5%, the bubble in the level must be kept between the two "MAX" marks.
- The longitudinal attitude must not exceed 15%, with the load facing uphill, and 10%, with the load facing downhill. - The jib angle must not exceed 45°.
- If the first red LED of the longitudinal stability limiter and warning device (⚠ 2 - DESCRIPTION: INSTRUMENTS AND CONTROLS) comes on while travelling, gently bring the telehandler to a halt and stabilise the load. Retract the telescope to reduce the offset of the load.

INSTRUCTIONS FOR USE AS A LOADER

For agricultural-type telehandlers (MLT range)

A - LOADING

⚠ IMPORTANT ⚠

You must not raise the jib if you have not checked the transverse attitude of the telehandler (INSTRUCTIONS FOR HANDLING A LOAD: D - TRANSVERSE ATTITUDE OF THE TELEHANDLER).

REMINDER: Make sure that the following operations can be performed with good visibility (← OPERATION INSTRUCTIONS UNLADEN AND LADEN: D - VISIBILITY).

FILLING THE BUCKET

- Place the bottom of the bucket in a horizontal position, just in contact with the ground (1) (fig. A1).
- Move forward gradually (2) while simultaneously raising the boom and tilting the bucket backwards (3), for improved filling and breakout (fig. A1).

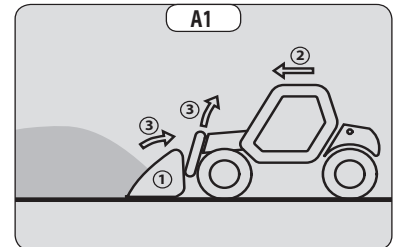

- Reverse the telehandler (1) very carefully and gently to free the bucket. Lower the boom (2) into the transport position (fig. A2).

⚠ IMPORTANT ⚠

Tilt the bucket sufficiently back to avoid spilling product and ensure its stability (loss of product under braking).

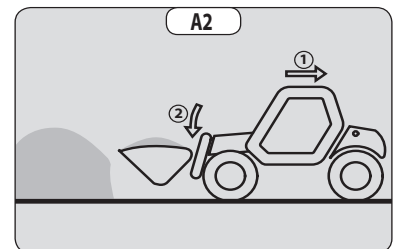

LOADING A TRAILER

- Approach the side of the trailer in the transport position (fig. A3).

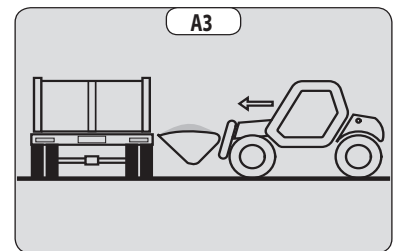

- Raise and extend the boom (1) (2) until the bucket is above the trailer, while monitoring the longitudinal stability limiter and warning device (← INSTRUCTIONS FOR HANDLING A LOAD: C - LONGITUDINAL STABILITY LIMITER AND WARNING DEVICE) (fig. A4).
- Drive the telehandler forward (3) very carefully and gently so that the bucket empties its load at the centre of the trailer (fig. A4).
- Apply the parking brake on and set the reversing lever to neutral.
- Slowly discharge the material (4) (fig. A4).

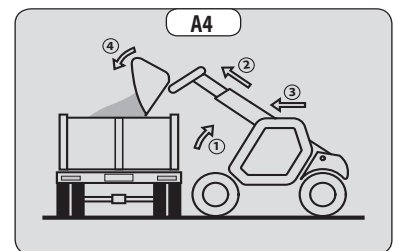

- Tilt back the bucket (1) and reverse the telehandler (2) very carefully and gently (fig. A5).
- Retract (3) and lower the boom (4) into the transport position (fig. A5).

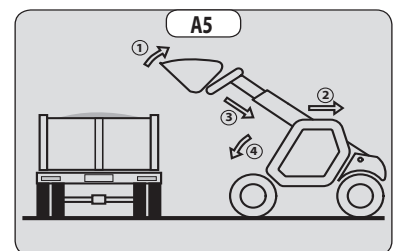

B - BACKFILLING

- Place the bottom of the bucket in a horizontal position, just in contact with the ground (1) (fig. B1).
- Drive forward gradually (2). Once filled, the bucket will act as a levelling blade (fig. B1).

⚠ IMPORTANT ⚠

When driving, beware of trenches as well as recently excavated and/or backfilled ground.

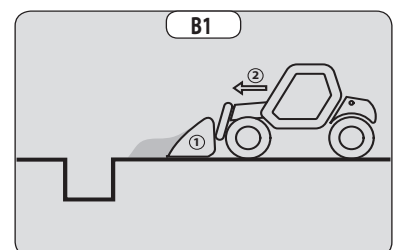



PLATFORM OPERATING INSTRUCTIONS

For telehandlers fitted with a PLATFORM

A - AUTHORISATION FOR USE

- Operation of the platform requires further authorisation in addition to that of the telehandler.

B - TELEHANDLER SUITABILITY FOR USE

- MANITOU has ensured that this platform is suitable for use under the normal operating conditions defined in this operator's manual, with a **STATIC test coefficient of 1.25** and a **DYNAMIC test coefficient of 1.1** as specified in harmonised standard **EN 280** for "mobile elevating work platforms".
- Before commissioning, the company manager must make sure that platform is appropriate for the work to be done, and perform certain tests (in accordance with current legislation).

C - PRECAUTIONS WHEN USING THE PLATFORM

- Wear suitable clothing when using the platform, avoid loosely-fitting garments.
- Never operate the platform when hands or feet are wet or soiled with greasy substances.
- Remain alert at all times when using the platform. Do not listen to the radio or music using headphones or earphones.
- For increased comfort, adopt the correct position at the platform's operator station.
- The platform's guard rail exempts the operator from wearing a safety harness under normal operating conditions. As a result, you are responsible for deciding whether to wear a safety harness.
- The control units must never in any event be used for any other than their intended purposes (e.g. climbing onto or down from the telehandler, portmanteau, etc.).
- Safety helmets must be worn.
- The operator must always be in the normal operator's position. It is prohibited to have arms or legs, or generally any part of the body, protruding from the basket.
- Ensure that any materials loaded onto the platform (pipes, cables, containers, etc.) cannot fall out. Do not pile these materials to the point where it is necessary to step over them.

D - USING THE PLATFORM

- However experienced they may be, operators must acquaint themselves with the emplacement and operation of all control instruments prior to operating the platform.
- Check before use that the platform has been correctly assembled and locked onto the telehandler.
- Check before operating the platform that the access gate has been properly locked.
- The platform should be operated in an area free of any obstructions or danger when it is lowered to the ground.
- The operator using the platform must be aided on the ground by a person with adequate training.
- You should stay within the limits set out in the platform load chart.
- The lateral constraints are limited (2 - DESCRIPTION: CHARACTERISTICS).
- It is strictly forbidden to suspend a load from the platform or the telehandler jib without a specially designed attachment (INSTRUCTIONS FOR HANDLING A LOAD: H - PICKING UP AND SETTING DOWN A SUSPENDED LOAD).
- The platform cannot be used as a crane or a lift for permanently transporting people or materials, nor as jacks or supports.
- The telehandler must not be moved with one (or more) person(s) in the platform.
- It is forbidden to transport people on the platform using the hydraulic controls in the telehandler's driver's cab (except in case of rescue).
- The operator must not climb onto to off the platform when it is not on ground level (jib retracted and in the down position).
- The platform must not be fitted with attachments that increase the unit's wind load.
- Do not use ladders or improvised structures in the platform to gain extra height.
- Do not climb onto the sides of the platform to gain extra height.
- It is forbidden to use the platform on forks. The fork slots are only to, be used for storing the platform and not for lifting people under any circumstances.

E - ENVIRONMENT

⚠ IMPORTANT ⚠

It is forbidden to use the platform close to electricity cables. Maintain the specified safe distances.

RATED VOLTAGE	SAFE DISTANCE m (ft)
50 < U < 1000	2,30 (7.54)
1000 < U < 30000	2,50 (8.20)
30000 < U < 45000	2,60 (8.53)
45000 < U < 63000	2,80 (9.18)
63000 < U < 90000	3,00 (9.84)
90000 < U < 150000	3,40 (11.15)
150000 < U < 225000	4,00 (13.12)
225000 < U < 400000	5,30 (17.38)
400000 < U < 750000	7,90 (25.91)

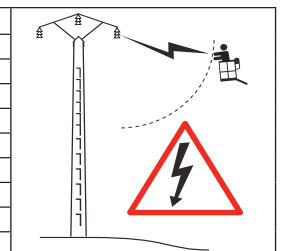



⚠ IMPORTANT ⚠

It is strictly forbidden to use the platform when the wind speed exceeds 45 km/h (27.9 mph).

- To visually recognise this wind speed, refer to the empirical wind evaluation scale below:

BEAUFORT scale (wind speed at a height of 10 m on a flat site)						
Force	Type of wind	Speed (knots)	Speed (km/h)	Speed (m/s)	Effects on Land	Sea conditions
0	Calm	0 - 1	0 - 1	< 0,3	Smoke rises vertically.	Sea is like a mirror.
1	Light air	1 - 3	1 - 5	0,3 - 1,5	Smoke indicates direction of wind.	Ripples with appearance of scale, no foam crests.
2	Light breeze	4 - 6	6 - 11	1,6 - 3,3	Wind felt on face, leaves rustle.	Short wavelets, but pronounced.
3	Gentle breeze	7 - 10	12 - 19	3,4 - 5,4	Leaves and small twigs in constant motion.	Very small waves, crests begin to break.
4	Moderate breeze	11 - 16	20 - 28	5,5 - 7,9	Wind raises dust and loose pieces of paper; small branches are moved.	Small waves, becoming longer, numerous whitecaps.
5	Fresh breeze	17 - 21	29 - 38	8 - 10,7	Small trees in leaf begin to sway.	Wavelets form on inland waters; moderate waves, taking longer form.
6	Strong breeze	22 - 27	39 - 49	10,8 - 13,8	Large branches in motion, whistling heard in overhead wires, umbrella use becomes difficult.	Larger waves forming, whitecaps everywhere, some spray.
7	Near gale	28 - 33	50 - 61	13,9 - 17,1	Whole trees in motion, inconvenience felt when walking against the wind.	Sea heaps up; white foam from breaking waves begins to be blown in streaks along the direction of the wind.
8	Gale	34 - 40	62 - 74	17,2 - 20,7	Wind breaks twigs off trees; impedes progress.	Moderately high waves of greater length; edges of crests begin to break into spindrift.
9	Strong gale	41 - 47	75 - 88	20,8 - 24,4	Wind damages roofs (chimneys, slates, etc.).	High waves, crests of waves begin to topple, streaks of foam; reduced visibility.
10	Storm	48 - 55	89 - 102	24,5 - 28,4	Seldom experienced inland; trees uprooted; considerable structural damage occurs.	Very high waves; white streaks of foam; reduced visibility.
11	Violent storm	56 - 63	103 - 117	28,5 - 32,6	Very rare, widespread damage.	Exceptionally high waves able to hide medium sized ships from view, reduced visibility.
12	Hurricane	64 +	118 +	32,7 +	Devastating damage.	Sea completely white; air filled with foam and spray, very reduced visibility.

F - MAINTENANCE

⚠ IMPORTANT ⚠

Your platform must be inspected periodically to ensure that it remains in compliance.

The frequency of this inspection is defined by the current legislation in force in the country in which the equipment is used

For France, this means one general periodic inspection every 6 months (Decree of 1 March 2004).



INSTRUCTIONS FOR USING THE RADIO-CONTROL

For telehandlers with RC radio control

HOW TO USE THE RADIO-CONTROL

SAFETY INSTRUCTIONS

- This radio-control consists of electronic and mechanical safety elements. It cannot receive commands from another transmitter because the internal encoding is unique to each radio-control.

⚠ IMPORTANT ⚠

If it is used improperly or incorrectly, there is a risk of danger to:

- *The physical and mental health of the user or others.*
- *The telehandler and other neighbouring items.*

Everyone working with this radio-control:

- *Must be qualified in line with current regulations and therefore appropriately trained.*
- *Must follow this instruction manual as closely as possible.*

- The system is used to control the telehandler remotely via radio waves. Commands are also transmitted if the telehandler is out of sight (behind an obstacle or a building for example), this is why:
 - After stopping the truck and removing the key switch (only possible when it is stationary), always place the transmitter in a safe, dry place.
 - Before performing any installation, servicing or repair work, always switch off power sources (in particular, electric welding devices and electric head units on hydraulic distributors must be disconnected at each section).
 - Never remove or alter the safety devices (such as the hand-guard frame, key, emergency stop button, etc.).

⚠ IMPORTANT ⚠

Never drive the telehandler if it is not continuously and perfectly within view of the operator!

- Before leaving the transmitter, the operator must make sure that it cannot be used by an unauthorized third person: either by removing the key button from the transmitter or locking it in an inaccessible place.
- The user must ensure that the instruction manual is accessible at all times and that operators have read and understood it.

INSTRUCTIONS

- Take up position in a stable place with no risk of slipping.
- Before using the transmitter, make sure there is nobody within the working area.
- Only use the transmitter with its carrying device or installed correctly on the platform.

⚠ IMPORTANT ⚠

When you remove the transmitter, remove the accumulator and key button so that it cannot be used accidentally or deliberately by anyone else.

PROTECTIVE DEVICES

- The telehandler will be immobilised within a maximum of 450 milliseconds (approx. 0.5 second):
 - If the emergency stop button of the transmitter is pressed (50 milliseconds), or that of the telehandler.
 - If the transmission distance of the radio waves is exceeded.
 - If the transmitter is faulty.
 - If an interfering radio signal is received from elsewhere.
 - If the accumulator is removed from its housing in the transmitter.
 - If the battery reaches the end of its autonomy.
 - If the transmitter is switched off by turning the key switch to the off position.
- These protective devices are provided for the safety of personnel and property and must never be modified, removed or bypassed in any way whatsoever!
- The hand-guard frame prevents external action on a manipulator (e.g. if the transmitter is dropped, or if the operator leans on a guard-rail).
- An electronic safety device prevents radio transmission from being initiated if the manipulators are not mechanically and electrically at rest and if the internal combustion engine speed selector is not set to idle.

⚠ IMPORTANT ⚠

In an emergency, press the transmitter emergency stop button immediately; then follow the manual's instructions (↩ 2 - DESCRIPTION: INSTRUMENTS AND CONTROLS).



TELEHANDLER MAINTENANCE INSTRUCTIONS

GENERAL INSTRUCTIONS

- Ensure the area is sufficiently ventilated before starting the telehandler.
- Wear clothes suitable for the maintenance of the telehandler, avoid wearing jewellery and loose clothes. Tie and protect your hair, if necessary.
- Stop the engine and remove the ignition key, when an intervention is necessary.
- Read the operator's manual carefully.
- Carry out all repairs immediately, even if the repairs concerned are minor.
- Repair all leaks immediately, even if the leak concerned is minor.
- Ensure that process materials and of spare parts are disposed in all safely and in an ecological manner.
- Be careful of the risk of burning and splashing (exhaust, radiator, engine, etc.).

PLACING THE JIB SAFETY WEDGE

- The telehandler is equipped with a jib safety wedge (↖ 2 - DESCRIPTION: INSTRUMENTS AND CONTROLS) that must be installed on the rod of the lifting cylinder when working beneath the jib.

FITTING THE WEDGE

- Fully raise the jib.
- Place the safety wedge 1 on the rod of the lifting cylinder and secure with the rod 2 and the pin 3.
- Slowly lower the jib then stop the hydraulic movements before it comes into contact with the wedge.

REMOVING THE WEDGE

- Fully raise the jib.
- Remove the pin and the rod.
- Return the safety wedge to the storage location provided on the telehandler.

⚠ IMPORTANT ⚠

Only use the wedge supplied with the telehandler.

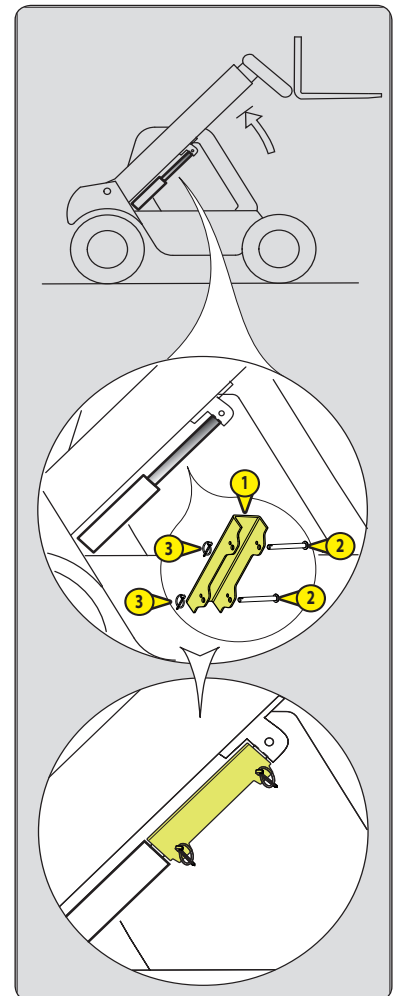

MAINTENANCE

- Perform the periodic service (↖ 3 - MAINTENANCE) to keep your telehandler in good working condition. Failure to perform the periodic service may cancel the contractual guarantee.

MAINTENANCE LOGBOOK

- The maintenance operations carried out in accordance with the recommendations given in part: 3 - MAINTENANCE and the other inspection, servicing or repair operations or modifications performed on the telehandler or its attachments shall be recorded in a maintenance logbook. The entry for each operation shall include details of the date of the works, the names of the individuals or companies having performed them, the type of operation and its frequency, if applicable. The part numbers of any telehandler items replaced shall also be indicated.



LUBRICANT AND FUEL LEVELS

- Use the recommended lubricants (never use contaminated lubricants).
- Do not fill the fuel tank when the engine is running.
- Only fill up the fuel tank in areas specified for this purpose.
- Do not fill the fuel tank to the maximum level.
- Do not smoke or approach the telehandler with a flame, when the fuel tank is open or is being filled.

HYDRAULIC SYSTEM

- Any work on the load handling hydraulic circuit is forbidden except for the operations described in part: 3 - MAINTENANCE.
- Do not attempt to loosen unions, hoses or any hydraulic component with the circuit under pressure.

⚠ IMPORTANT ⚠

COUNTERBALANCE VALVE: It is dangerous to change the settings and remove the counterbalance valves or safety valves which may be fitted to your telehandler cylinders. The **HYDRAULIC ACCUMULATORS** that may be fitted on your telehandler are pressurised units. Removing these accumulators and their pipework is a dangerous operation and must only be performed by approved personnel (consult your dealer).

ELECTRICITY

- Do not short-circuit the starter relay to start the engine. If the forward/reverse selector is not in neutral and the parking brake is not applied, the telehandler may suddenly start to move.
- Do not place metal items on the battery.
- Disconnect the battery before working on the electrical circuit.

WELDING

- Disconnect the battery before any welding operations on the telehandler.
- When carrying out electric welding work on the telehandler, connect the negative cable from the equipment directly to the part being welded, so as to avoid high tension current passing through the alternator.
- Never carry out welding or work which gives off heat on an assembled tyre. The heat would increase the pressure which could cause the tyre to explode.
- If the telehandler is equipped with an electronic control unit, disconnect this before starting to weld, to avoid the risk of causing irreparable damage to electronic components.

WASHING THE TELEHANDLER

- Clean the telehandler or at least the area concerned before any intervention.
- Remember to close and lock all accesses to the telehandler (doors, windows, cowls...).
- During washing, avoid the articulations and electrical components and connections.
- If necessary, protect against penetration of water, steam or cleaning agents, components susceptible of being damaged, particularly electrical components and connections and the injection pump.
- Clean the telehandler of any fuel, oil or grease trace.

TRANSPORTING THE TELEHANDLER

⚠ IMPORTANT ⚠

Transporting the telehandler involves real risks for the operator and others involved.

- Towing, slinging or transporting the telehandler (⚠ 3 - MAINTENANCE: OCCASIONAL OPERATION).



IF THE TELEHANDLER IS NOT TO BE USED FOR A LONG TIME

INTRODUCTION

The following recommendations are intended to prevent the telehandler from being damaged when it is withdrawn from service for an extended period.

⚠ IMPORTANT ⚠

Procedures to follow if the telehandler is not to be used for a long time and for starting it up again afterwards must be performed by your dealership. This long-term storage period must not exceed 12 months.

After 12 months, perform the telehandler return to service and long term shutdown procedures again.

PREPARING THE TELEHANDLER

- Clean the telehandler thoroughly.
- Check and repair any fuel, oil, water or air leaks.
- Replace or repair any worn or damaged parts.
- Wash the painted surfaces of the telehandler in clear and cold water and wipe them.
- Touch up the paintwork if necessary.
- Shut down the telehandler (⚠ OPERATING INSTRUCTIONS UNLADEN AND LADEN).
- Make sure the jib cylinder rods are all in retracted position.
- Release the pressure in the hydraulic circuits.

DEF (Diesel Exhaust Fluid) TANK

Depending on the model of telehandler - Drain and rinse the DEF tank.

- Replace the "DEF" (Diesel Exhaust Fluid) feed pump filter (⚠ 3 - MAINTENANCE: 1000 HOUR - PERIODIC MAINTENANCE - EVERY 1000 HOURS OF SERVICE OR EVERY 2 YEARS).
- Slowly fill the tank with new "DEF" (Diesel Exhaust Fluid) up to the bottom of the filler neck.
- Start up the telehandler to pressurise the circuit and bring it up to working temperature, then shut down the engine. - If necessary, top up the tank.

PROTECTING THE ENGINE

- Contact your dealer to obtain the procedure for protecting the inside of the engine (use of protection product).
- Fill the fuel tank.
- Empty and replace the cooling liquid (⚠ 3 - MAINTENANCE: 2000 HOUR - PERIODIC MAINTENANCE - EVERY 2000 HOURS OF SERVICE OR EVERY 4 YEARS).
- Leave the engine running at idling speed for a few minutes, then switch off.
- Replace the engine oil and oil filter (⚠ 3 - MAINTENANCE: 500 HOUR - PERIODIC MAINTENANCE - EVERY 500 HOURS SERVICE OR EVERY 1 YEAR).
- Run the engine for a short time so that the oil and cooling liquid circulate inside.
- Disconnect the battery and store it in a safe place away from the cold, after charging it to a maximum.
- Block the outlet with waterproof adhesive tape.
- Remove the drive belts and store them in a safe place.
- Disconnect the engine cut-off solenoid on the injection pump and carefully insulate the connection.

PROTECTING THE TELEHANDLER

- Set the telehandler on axle stands so that the tyres are off the ground.
- Release the parking brake (according to model of telehandler).
- Protect cylinder rods which will not be retracted, from corrosion.
- Wrap the tires.

NOTE: If the telehandler is to be stored outdoors, cover it with a waterproof tarpaulin.



BRINGING THE TELEHANDLER BACK INTO SERVICE

- Remove the waterproof adhesive tape from all the holes.
- Refit and reconnect the battery.
- Remove the protection from the cylinder rods.
- Carry out daily maintenance (⚠ 3 - MAINTENANCE: 10 HOUR - DAILY MAINTENANCE OR EVERY 10 HOURS OF SERVICE).
- Put the handbrake on and remove the axle stands.
- Empty and clean the fuel tank (⚠ 3 - MAINTENANCE: 1000 HOUR - PERIODIC MAINTENANCE - EVERY 1000 HOURS OF SERVICE OR EVERY 2 YEARS)
- Fill the fuel tank with clean diesel filtered through the filler port.
- Replace the fuel filter (⚠ 3 - MAINTENANCE: 500 HOUR - PERIODIC MAINTENANCE - EVERY 500 HOURS OF SERVICE OR EVERY 1 YEAR).
- Replace the fuel pre-filter (⚠ 3 - MAINTENANCE: 500 HOUR - PERIODIC MAINTENANCE - EVERY 500 HOURS OF SERVICE OR EVERY 1 YEAR) (according to model of telehandler).
- Drain and rinse the DEF tank (according to model of telehandler).
- Slowly fill the tank with new "DEF" (Diesel Exhaust Fluid) up to the bottom of the filler neck (according to model of telehandler).
- Refit and set the tension in the drive belts (⚠ 3 - MAINTENANCE: FILTER CARTRIDGES AND BELTS).
- Turn the engine over with the starter, to allow the oil pressure to rise.
- Reconnect the engine cut-off solenoid.
- Grease the telehandler completely (⚠ 3 - MAINTENANCE: 50 HOUR - WEEKLY MAINTENANCE OR EVERY 50 HOURS OF SERVICE).

⚠ IMPORTANT ⚠

Ensure the area is sufficiently ventilated before starting the telehandler.

- Start up the telehandler, following the safety instructions and regulations (⚠ OPERATING INSTRUCTIONS UNLADEN AND LADEN).
- Run all the jib's hydraulic movements, concentrating on the ends of travel for each cylinder.



TELEHANDLER DISPOSAL

⚠ IMPORTANT ⚠

Please consult your dealer before disposing of your telehandler.

RECYCLING OF MATERIALS

METALS

- Metals are 100 % recoverable and recyclable.

PLASTICS

- Plastic parts are identified with a marking in accordance with current regulations.
- A limited range of materials is used to simplify the recycling process.
- The majority of plastic components are made of "thermoplastic" plastics, that are easily recycled by melting, granulating or grinding.

RUBBER

- Tires and seals can be ground for use in cement manufacture or to obtain reusable granules.

GLASS

- Glass items can be removed and collected for processing by glaziers.

ENVIRONMENTAL PROTECTION

By entrusting the maintenance of your telehandler to the MANITOU network, the risk of pollution is limited and the contribution to environmental protection contribution is made.

WORN OR DAMAGED PARTS

- Do not dump them in the countryside.
- MANITOU and its network have signed-up to a scheme of environmental protection through recycling.

USED OIL

- The MANITOU network organizes the collection and processing of used oil products.
- By handing over your waste oil to MANITOU, the risk of pollution is limited.

USED BATTERIES

- Do not throw away batteries, as they contain metals that are harmful for the environment.
- Return them to the MANITOU network or any other approved collection point.

NOTE: MANITOU seeks to manufacture telehandlers that provide the best performance and limit polluting emissions.



2 - DESCRIPTION





TABLE OF CONTENTS

2 - DESCRIPTION

<u>CE DECLARATION OF CONFORMITY</u>	4
<u>SAFETY PLATES AND STICKERS</u>	6
<u>IDENTIFICATION OF THE TELEHANDLER</u>	10
<u>CHARACTERISTICS</u>	12
<u>FRONT AND REAR TYRES</u>	15
<u>DIMENSIONS AND LOAD CHARTS</u>	16
<u>LOAD CHART</u>	17
<u>VISIBILITY</u>	18
<u>INSTRUMENTS AND CONTROLS</u>	20
<u>TOWING PIN AND HOOK</u>	51
<u>DESCRIPTION AND USE OF THE OPTIONS</u>	55



CE DECLARATION OF CONFORMITY

1) **DECLARATION "CE" DE CONFORMITE (originale)**
" EC" DECLARATION OF CONFORMITY (original)

2) La société, *The company* : **MANITOU ITALIA S.r.l.**

3) Adresse, *Address* : **Via Cristoforo Colombo 2, 41013 Cavazzona in Castelfranco Emilia -ITALIE**

4) Dossier technique, *Technical file* : **MANITOU ITALIA S.r.l. Via Cristoforo Colombo 2, 41013 Cavazzona in Castelfranco Emilia (MO) , Italie**

5) Constructeur de la machine décrite ci-après, *Manufacturer of the machine described below* :

CHARIOT TELESCOPIQUE ROTATIF MRT 2150 PRIVILEGE N° 763407
NACELLE ORH EXTENSIBLE 2,25/4M - Capacité 365 Kg p.n. 711204 (GSS POSITION B)
PFB p.n.709835 + FOURCHES FEM 4999 KG p.n.578097 (GSS POSITION A)
TREUIL 5 TON p.n.711934 (GSS POSITION J)

6) Déclare que cette machine, *Declares that this machine* :

7)- Est conforme aux directives suivantes et à leurs transpositions en droit national, *Complies with the following directives and their transpositions into national law* :

2006/42/CE

8) - Pour les machines annexe IV, *Annex IV machines* :

9) - Numéro d'attestation, *Certificate number*: **ME.0017.10 REV.05 du, of 05/07/2011**

10) - Organisme notifié, *Notified body* : **ECO s.p.a. EUROPEAN CERTIFYNG ORGANIZATION, Via Mengolina 33 48018 Faenza- Ravenna - Italia - Organismo notificato n° 0714**

2000/14/CE + 2005/88/CE

11) -Procédure appliquée, *Applied procedure* : **Annexe VI – 2000 / 14 / CE proc.I**

10) - Organisme notifié, *Notified body* : **ECO s.p.a. EUROPEAN CERTIFYNG ORGANIZATION, Via Mengolina 33 48018 Faenza- Ravenna - Italia - Organismo notificato n° 0714**

12) - Niveau de puissance acoustique, *Sound power level* :

13) Mesuré, *Measured* : **103 dB (A)**

14) Garanti, *Guaranteed* : **104 dB (A)**

2004/108/CE

15)-Normes harmonisées utilisées, *Harmonised standards used* : **EN 12895, EN 280 :2001+A2 :2009**

16)-Normes ou dispositions techniques utilisées, *Standards or technical provisions used* : /

17) - Fait à, *Done at* : **CASTELFRANCO EMILIA** 18) - Date, *Date* : **04/01/2013**

19) - Nom du signataire, *Name of signatory* : **IOTTI MARCO**

20) - Fonction, *Function* : **DIRECTEUR GENERAL**

21) - Signature, *Signature* :

MANITOU ITALIA Srl
A Socio Unico - Sede Legale e Amm.va - Via C. Colombo, 2
Località Cavazzona - 41013 CASTELFRANCO E. (MO)
Tel. 052/959811 - Fax 052/959850
Cap. Soc. € 4.000.000 I.V.
Reg. Impr. Di Modena e CP. C.C. 173970369
P.IVA IT 02591050360 - N. Mecc. MO 033322 R.E.A. 148776



bg : 1) удостоверение за « CE » съответствие (оригинална), 2) Фирмата, 3) Адрес, 4) Техническо досие, 5) Фабрикант на описаната по-долу машина, 6) Обявява, че тази машина, 7) Отговаря на следните директиви и на тяхното съответствие национално право, 8) За машините към допълнение IV, 9) Номер на удостоверението, 10) Наименувана фирма, 15) хармонизирани стандарти използвани, 16) стандарти или технически правила, използвани, 17) Изработено в, 18) Дата, 19) Име на разписалия се, 20) Функция, 21) Функция.

cs : 1) ES prohlášení o shodě (původní), 2) Název společnosti, 3) Adresa, 4) Technická dokumentace, 5) Výrobce níže uvedeného stroje, 6) Prohlašuje, že tento stroj, 7) Je v souladu s následujícími směrnici a směrnici transponovanými do vnitrostátního práva, 8) Pro stroje v příloze IV, 9) Číslo certifikátu, 10) Notifikační orgán, 15) harmonizované normy použity, 16) Norem a technických pravidel používaných, 17) Místo vydání, 18) Datum vydání, 19) Jméno podepsaného, 20) Funkce, 21) Podpis.

da : 1) EF Overensstemmelseserklæring (original), 2) Firmaet, 3) Adresse, 4) tekniske dossier, 5) Konstruktor af nedenfor beskrevne maskine, 6) Erklærer, at denne maskine, 7) Overholder nedennævnte direktiver og disses gennemførelse til national ret, 8) For maskiner under bilag IV, 9) Certifikat nummer, 10) Bemyndigede organ, 15) harmoniserede standarder, der anvendes, 16) standarder eller tekniske regler, 17) Udfærdiget i, 18) Dato, 19) Underskrivers navn, 20) Funktion, 21) Underskrift.

de : 1) EG-Konformitätserklärung (original), 2) Die Firma, 3) Adresse, 4) Technischen Unterlagen, 5) Hersteller der nachfolgend beschriebenen Maschine, 6) Erklärt, dass diese Maschine, 7) den folgenden Richtlinien und deren Umsetzung in die nationale Gesetzgebung entspricht, 8) Für die Maschinen laut Anhang IV, 9) Bescheinigungsnummer, 10) Benannte Stelle, 15) angewandten harmonisierten Normen, 16) angewandten sonstigen technischen Normen und Spezifikationen, 17) Ausgestellt in, 18) Datum, 19) Name des Unterzeichners, 20) Funktion, 21) Unterschrift.

el : 1) Δήλωση συμμόρφωσης CE (πρωτότυπο), 2) Η εταιρεία, 3) Διεύθυνση, 4) τεχνικό φάκελο, 5) Κατασκευάστρια του εξής περιγραφόμενου μηχανήματος, 6) Δηλώνει ότι αυτό το μηχάνημα, 7) Είναι σύμφωνο με τις εξής οδηγίες και τις προσαρμογές τους στο εθνικό δίκαιο, 8) Για τα μηχανήματα παραρτήματος IV, 9) Αριθμός δήλωσης, 10) Κοινοποιημένος φορέας, 15) εναρμονισμένα πρότυπα που χρησιμοποιούνται, 16) Πρότυπα ή τεχνικούς κανόνες που χρησιμοποιούνται, 16) Είναι σύμφωνο με τα εξής πρότυπα και τεχνικές διατάξεις, 17) Εν, 18) Ημερομηνία, 19) Όνομα του υπογράφοντος, 20) Θέση, 21) Υπογραφή.

es : 1) Declaración DE de conformidad (original), 2) La sociedad, 3) Dirección, 4) expediente técnico, 5) Constructor de la máquina descrita a continuación, 6) Declara que esta máquina, 7) Está conforme a las siguientes directivas y a sus transposiciones en derecho nacional, 8) Para las máquinas anexo IV, 9) Número de certificación, 10) Organismo notificado, 15) normas armonizadas utilizadas, 16) Otras normas o especificaciones técnicas utilizadas, 17) Hecho en, 18) Fecha, 19) Nombre del signatario, 20) Función, 21) Firma.

et : 1) EÜ vastavusdeklaratsioon (algupärane), 2) Äriühing, 3) Aadress, 4) Tehniline dokumentatsioon, 5) Seadme tootja, 6) Kinnitab, et see toode, 7) On vastavuses järgmiste direktiivide ja nende riigisisesele õigusese ülevõtmiseks vastuvõetud õigusaktidega, 8) IV lisas loetletud seadmete puhul, 9) Tunnistuse number, 10) Sertifitseerimisasutus, 15) kasutatud ühtlustatud standardite, 16) Muud standardites või spetsifikatsioonides kasutatakse, 17) Väljaandmise koht, 18) Väljaandmise aeg, 19) Allkirjastaja nimi, 20) Amet, 21) Allkiri.

fi : 1) EY-vaatimustenmukaisuusvakuutus (alkuperäiset), 2) Yritys, 3) Osasto, 4) teknisen eritelmän, 5) Jäljessä kuvattu koneen valmistaja, 6) Vakuuttaa, että tämä kone, 7) Täyttää seuraavien direktiivien sekä niitä vastaavien kansallisten säännösten vaatimukset, 8) Liitteen IV koneiden osalta, 9) Todistuksen numero, 10) Ilmoitettu laitos, 15) yhdenmukaistettuja standardeja käytetään, 16) muita standardeja tai, 17) Paikka, 18) Aika, 19) Allekirjoittajan nimi, 20) Toimi, 21) Allekirjoitus.

ga : 1) « EC » dearbhú comhréireachta (bunaidh), 2) An comhlacht, 3) Seoladh, 4) comhad teicniúil, 5) Déantóir an innill a thuiscítear thar lear, 6) Déanann sé go bhfuil an t-inneall, 7) Go gclóinn sé le na teorachta seo a leanas agus a trasúimh isteach i ndlí náisiúnta, 8) Le haghaidh innill an aguisín, 9) Uimhir teicnící, 10) Comhlacht a chuireadh i bhfios, 15) caighdeán comhchuibhithe úsáidtear, 16) caighdeán eile nó sonraíochtaí teicniúla úsáidtear, 17) Déanta ag, 18) Dáta, 19) Ainm an tsíniitheoraigh, 20) Síniú.

hu : 1) CE megfelelő ségi nyilatkozat (eredeti), 2) A vállalat, 3) Cím, 4) műszaki dokumentáció, 5) A gép gyártója, 6) Nyilatkozik, hogy a gép, 7) Megfelel az alábbi irányelveknek valamint azok honosított előírásainak, 8) A IV. melléklet gépeihez, 9) Bizonylati szám, 10) Notifikált szervezet, 15) felhasznált harmonizált szabványok, 16) egyéb felhasznált műszaki szabványok és előírások hivatkozásai, 17) Kelt (hely), 18) Dátum, 19) Aláírás, 20) Cím, 21) Aláírás.

is : 1) Samræmisvottorð ESB (upprunalega), 2) Fyrirtækið, 3) Aðsetur, 4) Tæknileg gögna, 5) Gætt af höfundinum, 6) Lýst er hér á eftir, 7) Staðfestir að tækið, 8) Samræmist eftirfarandi stöðlum og staðfærslu þeirra með hljóðjón af þjóðarrétti, 8) Fyrirtæki í aðalafli, 9) Staðfestingarnúmer, 10) Tilkynnt til, 15) samhæfa staðla sem notaðir, 16) önnur staðlar eða forskrifir notað, 17) Staður, 18) Dagsetning, 19) Nafn undirritaðs, 20) Staða, 21) Indirskrift.

it : 1) Dichiarazione CE di conformità (originale), 2) La società, 3) Indirizzo, 4) fascicolo tecnico della struttura della macchina descritta di seguito, 6) Dichiaro che questa macchina, 7) È conforme alle direttive seguenti e alle relative trasposizioni nel diritto nazionale, 8) Per le macchine all' annesso IV, 9) Numero di Attestazione, 10) Organismo notificato, 15) norme armonizzate applicate, 16) altre norme e specifiche tecniche applicate, 17) Stabilita a, 18) Data, 19) Nome del firmatario, 20) Funzione, 21) Firma.

lt : 1) CE atitikties deklaracija (originalas), 2) Bendrovė, 3) Adresas, 4) Techninė byla, 5) Žemiau nurodytas įrenginio gamintojas, 6) Pareiškia, kad šis įrenginys, 7) Atitinka toliau nurodytas direktyvas ir į nacionalinius teisės aktus perkeltas nuostatas, 8) IV priede išvardintoms mašinoms, 9) Sertifikato Nr, 10) Paskelbtoji įstaiga, 15) suderintus standartus naudojamus, 16) Kiti standartai ir techninės specifikacijos, 17) Pasirašyta, 18) Data, 19) Įmonės pavadinimas, 20) Pareigos, 21) Parašas.

lv : 1) EK atbilstības deklarācija (originals), 2) Uzņēmums, 3) Adrese, 4) tehniskās lietas, 5) Tālāk aprakstītās iekārtas ražotājs, 6) Apliecinā, ka šī iekārta, 7) Ir atbilstoša tālāk norādītajām direktīvām un to transpozīcijai nacionālajā likumdošanā, 8) Iekārtas ražotājs, 9) Apliecināšanas numurs, 10) Reģistrētā organizācija, 15) lietotajiem saskaņotajiem standartiem, 16) lietotajiem tehniskajiem standartiem un specifikācijām, 17) Izstrādāts, 18) Datums, 19) Parakstītāja vārds, 20) Amats, 21) Paraksts.

mt : 1) Dikjarazzjoni ta' Konformitàta CE (originali), 2) Il-kumpanija, 3) Indirizz, 4) fajl tekniku, 5) Manifattriċi tal-magna deskritta hawn isfel, 6) Tididkjarja li din il-magna, 7) Hija konformi hija konformi mad-Direttivi segwenti u l-Ilijijiet li jimplimentawhom fil-ligi nazzjonali, 8) Għall-magni fl-Anness IV, 9) Numru taċ-certifikat, 10) Entità nnotifikata, 15) l-istandards armonizzati użati, 16) standards tekniċi u specifikazzjonijiet oħra użati, 17) Magħmul f', 18) Data, 19) Isem il-firmatarju, 20) Kariga, 21) Firma.

nl : 1) EG-verklaring van overeenstemming (oorspronkelijke), 2) Het bedrijf, 3) Adres, 4) technisch dossier, 5) Constructeur van de hierna genoemde machine, 6) Verklaart dat deze machine, 7) In overeenstemming is met de volgende richtlijnen en hun omzettingen in het nationale recht, 8) Voor machines van bijlage IV, 9) Goedkeuringsnummer, 10) Aangezegde instelling, 15) gehanteerde geharmoniseerde normen, 16) andere gehanteerde technische normen en specificaties, 17) Opgemaakt te, 18) Datum, 19) Naam van ondergetekende, 20) Functie, 21) Handtekening.

no : 1) CE-samsvarserklæring (original), 2) Selskapet, 3) Adresse, 4) tekniske arkiv, 5) Fabrikant av følgende maskin, 6) Erklærer at denne maskinen, 7) Oppfyller kravene i følgende direktiver, med nasjonale gjennomføringsbestemmelser, 8) For maskinene i tillegg IV, 9) Attestnummer, 10) Notifisert organ, 15) harmoniserte standarder som brukes, 16) Andre standarder og spesifikasjoner brukt, 17) Utstedt i, 18) Dato, 19) Underskrivers navn, 20) Stilling, 21) Underskrift.

pl : 1) Deklaracja zgodności CE (oryginalne), 2) Spółka, 3) Adres, 4) dokumentacji technicznej, 5) Wykonawca maszyny opisanej poniżej, 6) Oświadcza, że ta maszyna, 7) Jest zgodna z następującymi dyrektywami i odpowiadającymi przepisami prawa krajowego, 8) Dla maszyn załącznik IV, 9) Numer certyfikatu, 10) Jednostka certyfikująca, 15) zastosowanych norm zharmonizowanych, 16) innych zastosowanych norm technicznych i specyfikacji, 17) Sporządzono w, 18) Data, 19) Nazwisko podpisującego, 20) Stanowisko, 21) Podpis.

pt : 1) Declaração de conformidade CE (original), 2) A empresa, 3) Morada, 4) processo técnico, 5) Fabricante da máquina descrita abaixo, 6) Declara que esta máquina, 7) Está em conformidade às directivas seguintes e às suas transposições para o direito nacional, 8) Para as máquinas no anexo IV, 9) Número de certificado, 10) Entidade notificada, 15) normas harmonizadas utilizadas, 16) outras normas e especificações técnicas utilizadas, 17) Elaborado em, 18) Data, 19) Nome do signatário, 20) Cargo, 21) Assinatura.

ro : 1) Declarație de conformitate CE (originală), 2) Societatea, 3) Adresa, 4) cãrtii tehnice, 5) Constructor al mașinii descrise mai jos, 6) Declară că prezenta mașină, 7) Este conformă cu directivele următoare și cu transpunerea lor în dreptul național, 8) Pentru mașinile din anexa IV, 9) Număr de atestare, 10) Organism notificat, 15) standardele armonizate utilizate, 16) alte standarde și specificații tehnice utilizate, 17) Întocmit la, 18) Data, 19) Numele persoanei care semnează, 20) Funcția, 21) Semnătura.

sk : 1) ES vyhlásenie o zhode (pôvodný), 2) Názov spoločnosti, 3) Adresa, 4) technickej dokumentácie, 5) Výrobca nižšie opísaného stroja, 6) Vyhlasuje, že tento stroj, 7) Je v súlade s nasledujúcimi smernicami a smernicami transponovanými do vnútroštátneho práva, 8) Pre stroje v prílohe IV, 9) Číslo certifikátu, 10) Notifikačný orgán, 15) použité harmonizované normy, 16) použité iné technické normy a predpisy, 17) Miesto vydania, 18) Dátum vydania, 19) Meno podpisujúceho, 20) Funkcia, 21) Podpis.

sl : 1) ES Izjava o ustreznosti (izvirna), 2) Družba, 3) Naslov, 4) tehnične dokumentacije, 5) Proizvajalac tukaj opisanega stroja, 6) Izjavlja, da je ta stroj, 7) Ustreza naslednjim direktivam in njihovi transpoziciji v državno pravo, 8) Za stroje priloga IV, 9) Številka potrdila, 10) Obvestilo organu, 15) uporabljene harmonizirane standarde, 16) druge uporabljene tehnične standarde in zahteve, 17) V, 18) Datum, 19) Ime podpisnika, 20) Funkcija, 21) Podpis.

sv : 1) CE-försäkran om överensstämmelse (original), 2) Företaget, 3) Adress, 4) tekniska dokumentationen, 5) Konstruktor av nedan beskrivna maskin, 6) Försäkrar att denna maskin, 7) Överensstämmer med nedanstående direktiv och införlivandet av dem i nationell rätt, 8) För maskinerna i bilaga IV, 9) Nummer för godkännande, 10) Organism som underrättats, 15) Harmoniserade standarder som använts, 16) andra tekniska standarder och specifikationer som använts, 17) Upprättat i, 18) Datum, 19) Namn på den som undertecknat, 20) Befattning, 21) Namnteckning.



SAFETY PLATES AND STICKERS

⚠ IMPORTANT ⚠

Clean all of the stickers and safety plates to make them legible.
It is essential to replace stickers and safety plates which are illegible or damaged.
Check the presence of stickers and safety plates after replacing any spare parts.

EXTERNAL PLATES AND STICKERS

POINT	REFERENCE	DESCRIPTION
1	289101	Fixing Point
2	24653C	Lifting Point
3	296733	Set battery switch
4	932095	Safe moving parts
5	296751	Not practicable area
6	250707	Reversible fan
7	716907	Flammable warning
8	296751	Diesel caburante
9	716909	Hydraulic oil tank
10	881051	Wheel torque and tire pressure
11	296998	Can not be placed under or over the forks
12	234805	Instructions for the hydraulic coupling

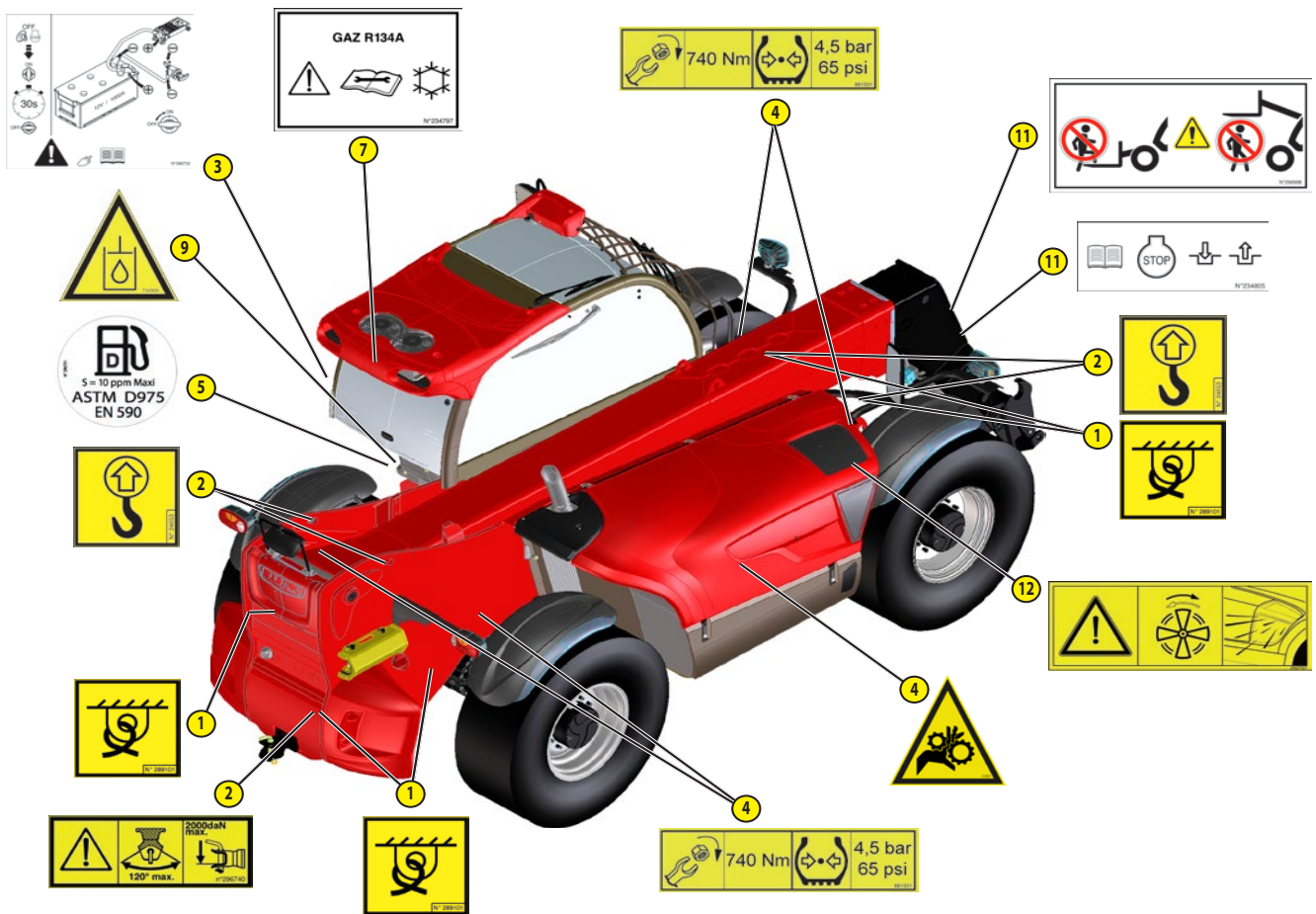

STICKERS AND PLATES UNDER THE ENGINE HOOD

POINT	REFERENCE	DESCRIPTION
1	716905	Danger hot surface
2	716919	Attention to the air inlet
3	293887	Engine coolant
4	716926	Risk of leakage of the coolant
5	716906	Shear hands
6	296741	Walking surface
7	716907	Flammable liquid hazard
8	909050	Risk of electric shock
9	930984	Plate fuses PowerBox
10	288430	Repair tools
11	716925	Fluid pressure hazard

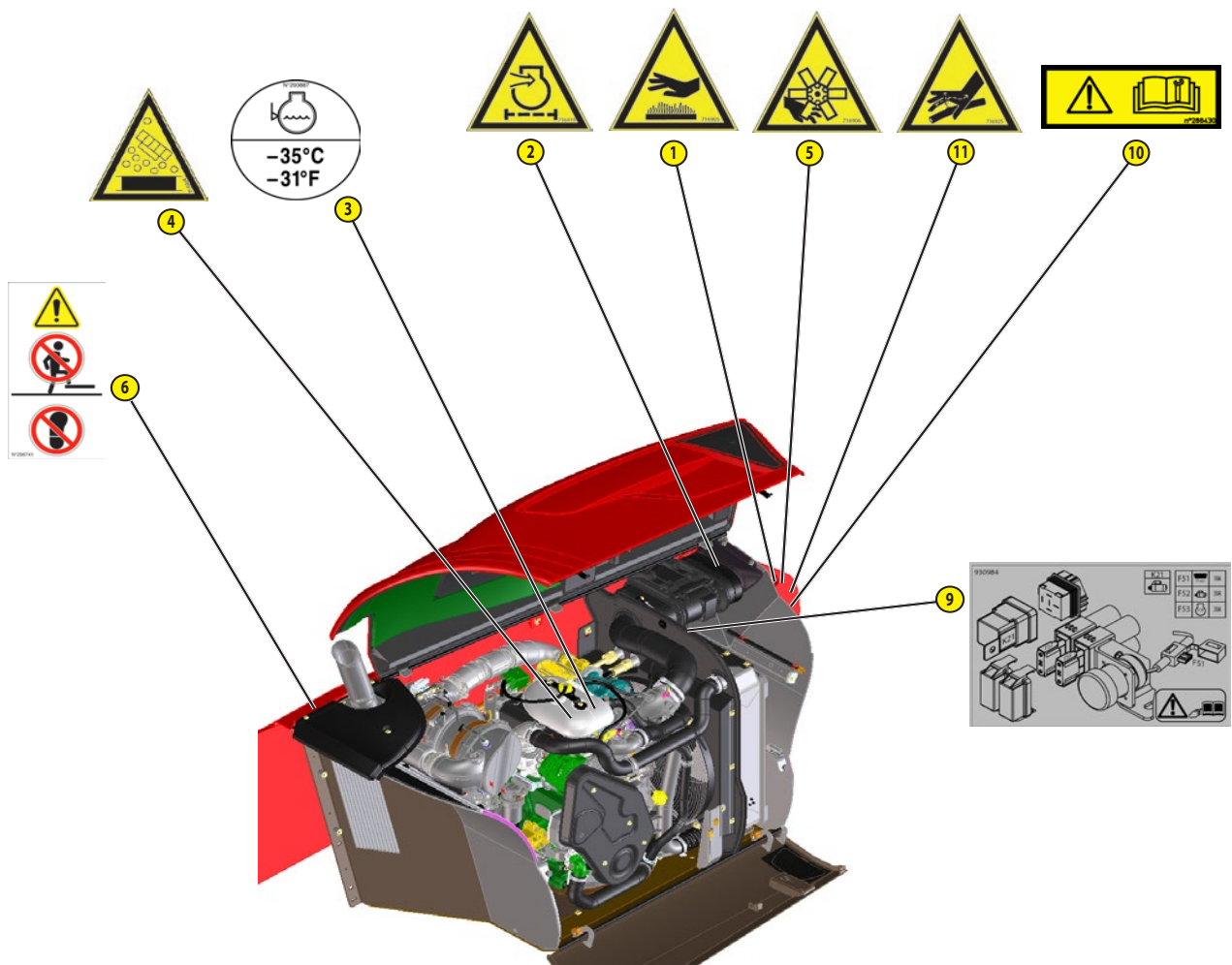



STICKERS AND PLATES IN THE CAB

POINT	REFERENCE	DESCRIPTION
1	268491	- Instructions oil brake
2	239596	- Sound power 106dB
3	302780	- Instructions driver presence / start
4	297735	- Instructions operation mode
5	290183	- Dump set on telescope
6	184276	- Control direction selector
7	193032	- Conformity cab
8	223324	- Patents
9	296739	- Cab approval (depending on model)
10	Consulter votre concessionnaire	- Nameplate
11	930983	- Fuses
12	261307	- Instruction operator schedule
13	53001068	- Load chart + function manipulator
14	296749	- Instructions + tire pressure lubrication
15	933345	- Excluding rollover



IDENTIFICATION OF THE TELEHANDLER

As our policy is to promote a constant improvement of our products, our range of telescopic telehandlers may undergo certain modifications, without obligation for us to advise our customers.

When you order parts, or when you require any technical information, always specify:

NOTE: For the owner's convenience, it is recommended that a note of these numbers is made in the spaces provided at the time of the delivery of the telehandler.

TELEHANDLER MANUFACTURER'S PLATE

- 1 - MODEL
- 2 - SERIES
- 3 - Year of manufacture
- 4 - Model year
- 5 - Serial No.
- 6 - Power ISO 3046
- 7 - Empty ground
- 8 - Authorised gross vehicle weight
- 9 - Rated capacity
- 10 - Drag strain
- 11 - Maximum vertical force (on trailer hook)
- 12 - Tyre pressure (bar)
- 13 - Homologation no.

For any further technical information regarding your telehandler refer to chapter: 2 - DESCRIPTION: CHARACTERISTICS.

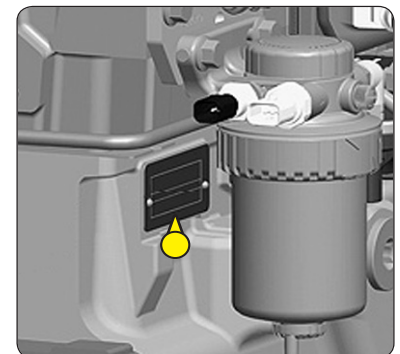
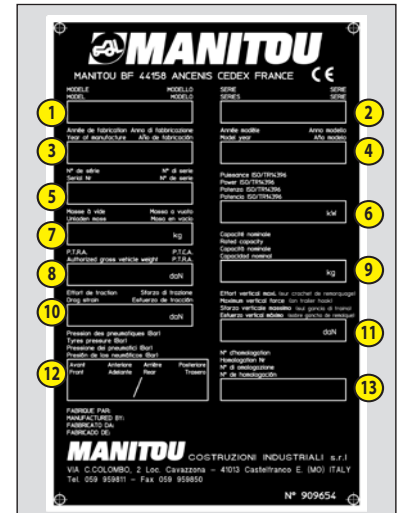

I.C. ENGINE

- Model
- Serial No.

GEAR BOX

- Type
- MANITOU reference
- Serial No.



FRONT AXLE

- Type
- Serial No.
- MANITOU reference





REAR AXLE

- Type
- Serial No.
- MANITOU reference

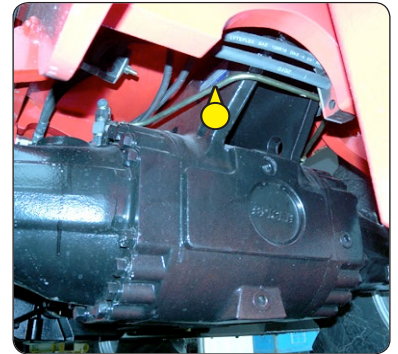

CAB

- Type
- Serial No.



BOOM

- MANITOU reference
- Date of manufacture



CHASSIS

- Lift truck serial no.

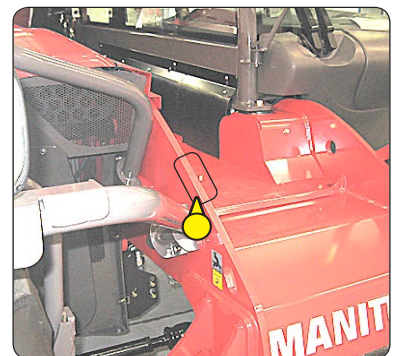

CONNECTION MANUFACTURER'S PLATE

1. Model
2. Serial no.
3. Year of manufacture
4. Unladen weight
5. centre of gravity
6. Operating pressure
7. Nominal capacity

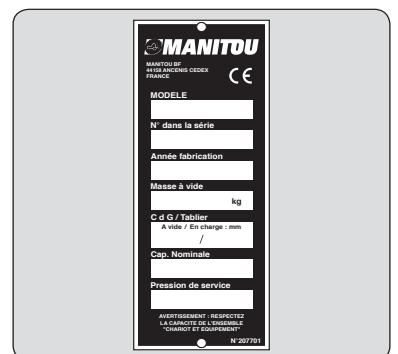



CHARACTERISTICS

I.C. ENGINE		
Engine		JOHN DEERE St.4 (Tier IV)
- Type		4045PWL-104 kW
- Fuel		Diesel
- Number of cylinders		4 in-line
- Intake		Turbocharged
- Injection system		Direct
- Firing order		1.3.4.2
- Displacement	cm ³ - L	4500 - 4.5
- Bore and stroke	mm - in	106 x 127 - 4.17 x 5
- Compression ratio		17
- Nominal speed at full load	rpm	2200
- Idle speed when unladen	rpm	850
- Maximum speed when unladen	rpm	2360
- ISO 3046 Power	HP - kW	140 - 104
- SAE J 1995 Power	HP - kW	140 - 104
- ISO 3046 max torque	Nm - kgf	534 - 54.45 @ 1500 rpm
- After-treatment type		DOC/SCR
- ISO 5011 gravimetric efficiency	%	99,9
Cooling system		
- Coolant circuit		Fluid
- Hydraulic oil cooling circuit		Hydraulic cooling
- Air cooling circuit		Air intake
- Ventilation system		Electrohydraulic
- Fan motor type		Hydraulic
- Fan speed	rpm	2550
- Number of fan blades		5
- Fan diameter	mm - in	660 - 25.98
TRANSMISSION		
Hydrostatic pump		
- Type		Variable volume pistons.
- Displacement	cm ³ - L	85 - 0.085
- Max flow rate	L/min.	280
- Operating pressure	bar - psi	450 - 6526.71
Hydrostatic motor (1)		
- Type		Variable volume
- Capacity min./max.	cm ³ /rev	0 to 115
Hydrostatic motor (2)		
- Type		Variable volume
- Capacity min./max.	cm ³ /rev	20 a 60
Gearbox		
- Type		Mechanical with hydraulic drive
- Number of forward speeds		1
- Number of reverse speeds		1
Speed inverter		
		Electromagnetic
Front axle		
- Differential		Without block
Rear axle		
- Differential		Without block
Driving wheels		
		4 permanent driving wheels
Front tyres		
		ALLIANCE
- Size		500/70 - R24 AGRO-IND RADIAL R-4 (580)
- Pressure	bar - psi	4,0 - 58
Rear tyres		
		ALLIANCE
- Size		500/70 - R24 AGRO-IND RADIAL R-4 (580)
- Pressure	bar - psi	4,0 - 58
ELECTRIC CIRCUIT		
Battery		12 V - 180 Ah - 1000 A EN
Alternator		
- Type		14 V - 120 A BOSCH HD 8
Starter		
- Type		12 V - 3,8 kW ISKRA



BRAKE CIRCUIT	
Service brake	Hydraulic power brake
- Type of brake	Multidisc brake immersed in oil
- Type of control	Foot-operated for the front and rear axles
Parking brake	Low pressure brake
- Type of brake	Disk on gear-box output
- Type of control	Electro-hydraulic

SOUND AND VIBRATION		
Sound pressure level in the driver's cab LpA (according to NF EN 12053)	dB(A)	80 (cab closed)
Sound pressure (according to directive 2009/76)	dB(A)	(cab closed); (cab open)
Sound pressure level ensured in the LwA environment (according to directive 2000/14/EC modified by directive 2005/88/EC)	dB(A)	105 (measured); 105 (guaranteed)
Sound level in motion (according to directive 2009/63)	dB(A)	
Average weighted acceleration on driver's body (according to NF EN 13059)	m/s ²	0,786
The average weighted acceleration transmitted to the driver's hand/ arm system (as per ISO 5349-2)	m/s ²	< 2,5
Standard seat vibration	m/s ²	1,14 (lightweight operator); 0,91 (heavyweight operator)

CIRCUIT HYDRAULIQUE			
Primary hydraulic pump			
- Type			piston variable displacement.
- Displacement	cm ³ - L		85 - 0.085
- Max. rating capacity unladen	L/min		180
- pressure	bar - psi		450 - 6526.71
Auxiliary hydraulic pump			
- Type			Gear pump.
- Displacement	cm ³ - L		22,5 - 0.0225
- Max. rating capacity unladen	L/min		49,5
- Pressure	bar - psi		210 - 3045.79
Filtration			
- Return	µm		10
- Suction	µm		135
Main electrovalves			
- Type			Distributor
Maximum working pressure	bar - psi		280 - 4061.06
- Lifting circuit	L/min bar-psi	190 - 145	280 - 4061
- Telescoping circuit	L/min bar-psi	190 - 145	250 - 280/3625.9 - 4061
- Tilting circuit	L/min bar-psi	190 - 190	220 - 290/31.90.8 - 4206
- Attachment circuit	L/min bar-psi	120-120	280 - 4061
- Steering circuit	L/min bar-psi	180	175 - 2538.16
- Brakes circuit	bar - psi		25 ÷ 40 - 362.59 ÷ 580.15

HYDRAULIC MOVEMENTS		
Longitudinal stability limiter and warning device		Electronic
Lifting motions (boom retracted)		
- Unladen lifting	s	8,5
- Laden lifting	s	9,3
- Unladen lowering	s	6,5
- Laden lowering	s	5,5
Telescoping motions (boom raised)		
- Unladen extending	s	7,0
- Laden extending	s	7,5
- Unladen retracting	s	6,0
- Laden retracting	s	6,5
Tilting movements		
- Unladen digging	s	3,8
- Forward tilting unladen	s	3,6



SPÉCIFICATIONS ET MASSES

Speed of movement for telehandler in standard configuration on flat ground			
Maximum speed			
- Forward unladen	km/h - mph	40 - 24.85	
- Forward laden	km/h - mph	40 - 24.85	
- Rear unladen	km/h - mph	32 - 19.88	
- Rear laden	km/h - mph	10 - 6.21	
Standard attachment	mm - in	1200x200x60 - 47.24x7.87x2.36	
- Weight with forks	kg - lb	200 - 440.92	
- Weight of forks (each one)	kg - lb	78 - 171.96	
Rated capacity with standard attachment	kg - lb	6000 - 13227.73	
Tipping load at maximum reach on stabilisers	kg - lb	-	
Distance from the centre of gravity from the load to the lug of the forks	mm - in	600 - 23.62	
Standard lifting height	m - ft	9 - 29.52	
Lift truck ground without attachment	kg - lb	-	
Lift truck ground with standard attachment		-	
- Unladen	kg - lb	11400 - 25132.70	
- At rated load	kg - lb	17400 - 38360.44	
Ground per axle with standard attachment (transport position)			
- Front unladen	kg - lb	4400 - 9700.34	
- Rear unladen	kg - lb	7000 - 15432.36	
- Front rated load	kg - lb	-	
- Rear rated load	kg - lb	-	
Ground per axle with standard attachment (boom extended)			
- Front rated load	kg - lb	-	
- Rear rated load	kg - lb	-	
Drag strain on the coupling hook			
- Unladen (sliding)	daN - kgf	10000 - 10197	
- At rated load (transmission setting)	daN - kgf		
Pull strain with open carrier (according to ISO 8313)	CBR 1500	daN - kgf	7300 - 7443.92
	CBA 4000	daN - kgf	4370 - 4456.15



FRONT AND REAR TYRES

		PRESSURE bar (psi)	LOAD PER TYRE (kg) [lb]			
			FORWARD UNLADEN kg (lb)	LADEN FRONT	REVERSE UNLADEN	LADEN REAR
ALLIANCE	500/70 - R24 AGRO-IND RADIAL R-4 (580)	4,0 (58)	2275 (5015.51)		3575 (7881.51)	
MICHELIN	500/70 - R24 IND TL 164A8/B XMCL					
ALLIANCE	17.5 - R25 ALL STEEL RADIAL - GPR (925)					
MITAS	17.5 - R25 EM60 171B					

		PRESSURE bar (psi)	LOAD kg (lb)	PRESSURE TO THE GROUND (kg/cm ²)		GROUND CONTACT SURFACE (cm ²)	
				COMPACT SOIL	CRUMBLING SOIL	COMPACT SOIL	CRUMBLING SOIL
				ALLIANCE	500/70 - R24 AGRO-IND RADIAL R-4 (580)	4,0 (58)	925 (2039.27)
1820 (4012.40)	7,07	1,96	195				704
2380 (5246.99)	8,69	2,40	305				1105
5275 (11629.37)	8,73	2,42	315				1135
MICHELIN	500/70 - R24 IND TL 164A8/B XMCL	925 (2039.27)	6,61	1,83	165		596
		1820 (4012.40)	7,07	1,96	195		704
		2380 (5246.99)	8,69	2,40	305		1105
		5275 (11629.37)	8,73	2,42	315		1135
ALLIANCE	17.5 - R25 ALL STEEL RADIAL - GPR (925)	925 (2039.27)	6,61	1,83	165		596
		1820 (4012.40)	7,07	1,96	195		704
		2380 (5246.99)	8,69	2,40	305		1105
		5275 (11629.37)	8,73	2,42	315		1135
MITAS	17.5 - R25 EM60 171B	925 (2039.27)	6,61	1,83	165	596	
		1820 (4012.40)	7,07	1,96	195	704	
		2380 (5246.99)	8,69	2,40	305	1105	
		5275 (11629.37)	8,73	2,42	315	1135	



DIMENSIONS AND LOAD CHARTS

	mm	in
A	1200	47,24
B	3000	118,11
C	1648	64,88
C1	1511	59,49
D	6106	240,39
D1	5969	235,00
D2	5110	201,18
E	7306	287,64
F	1970	77,56
F1	1970	77,56
G	450	17,72
G1	450	17,72
G2	490	19,29
I	1459	57,44
J	995	39,17
L	60	2,36
N	1891	74,45
O	200	7,87
P2	42°	
P3	23°	
R	4050	159,45
S	8654	340,71
T	4168	164,09
U1	2530	99,61
U2	2670	105,12
V	5492	216,22
V1	1325	52,17
V2	4303	169,41
W	2482	97,72
Y	12°	
Z	138°	

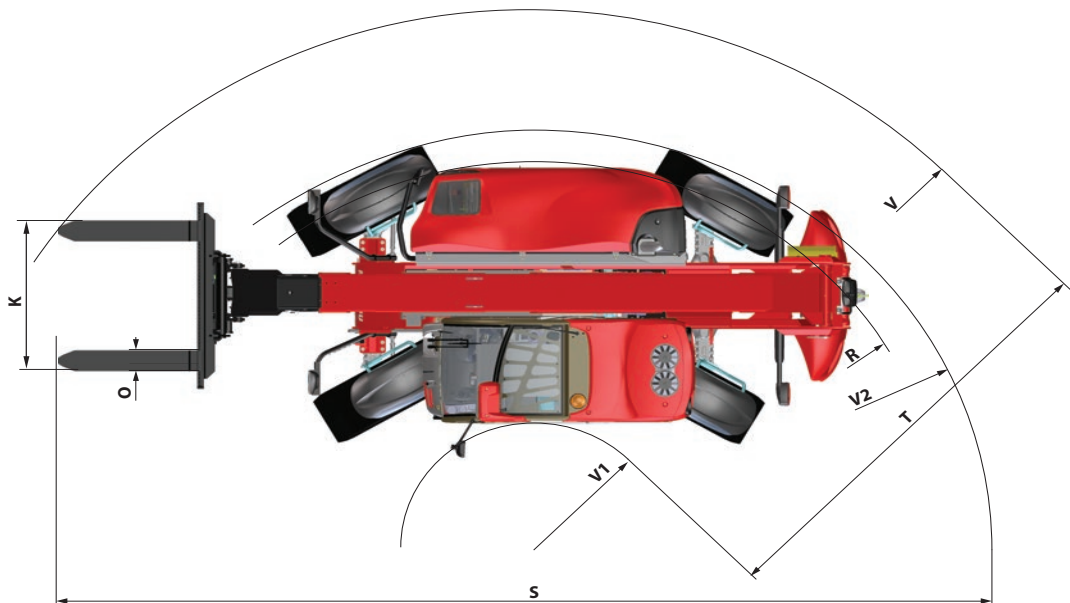
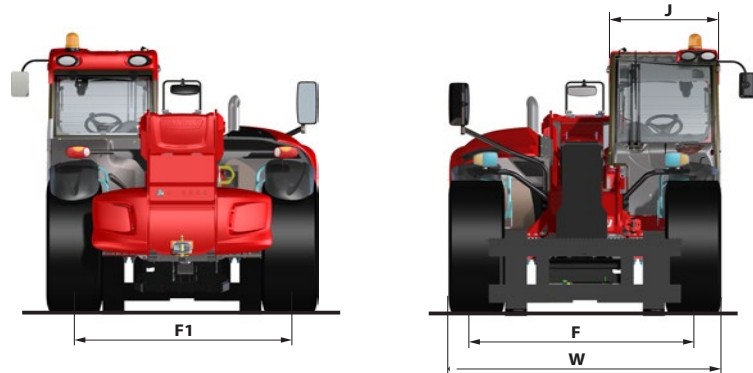
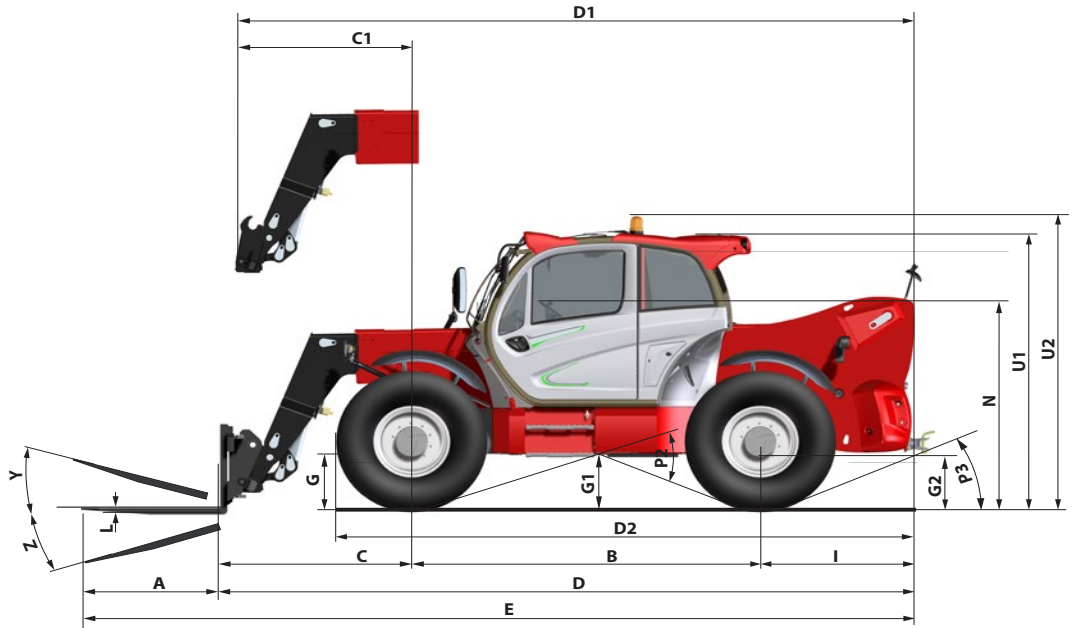



LOAD CHART

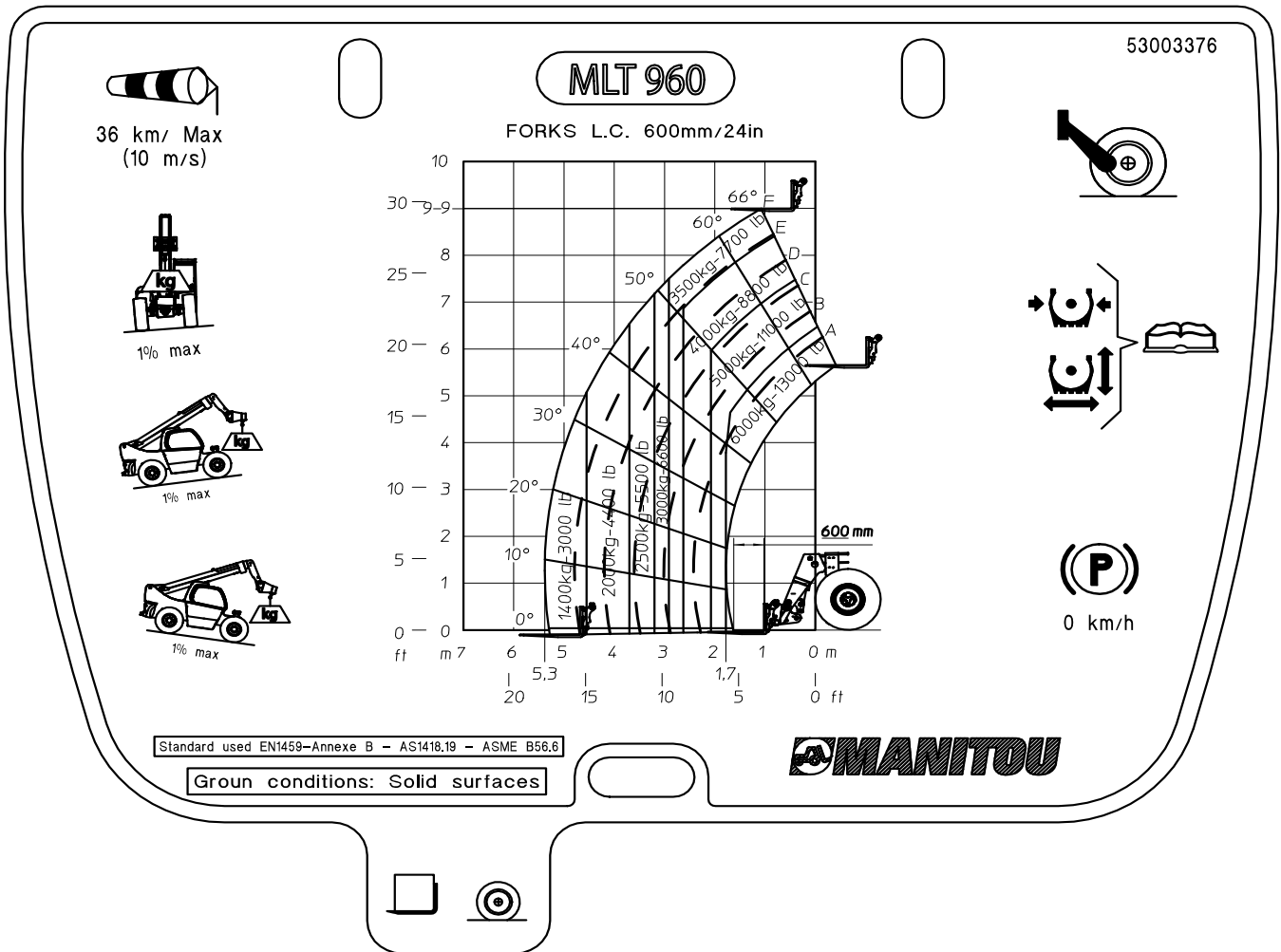

VISIBILITY

Our telehandlers conform to European standard EN15830 with regard to operator visibility.

- Follow the instructions for optimizing operator visibility of the immediate vicinity (see: 1 - OPERATING AND SAFETY INSTRUCTIONS: INSTRUCTIONS TO THE OPERATOR: DRIVING INSTRUCTIONS UNLADEN AND LADEN: D - VISIBILITY).

DESCRIPTION AND ADJUSTMENT OF REAR-VIEW MIRRORS

- 1 - LEFT REAR-VIEW MIRROR
- 2 - MAIN RIGHT REAR-VIEW MIRROR
- 3 - CENTRAL RIGHT REAR-VIEW MIRROR
- 4 - UPPER RIGHT REAR-VIEW MIRROR
- 5 - REAR REAR-VIEW MIRROR

- Place the telehandler on level ground with the I.C. engine stopped, and the telescopic boom retracted and lowered as far as possible.
- Note the position of the reference points ●...○ in the illustrations, to see and correctly adjust the rear-view mirrors.

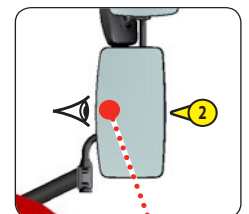
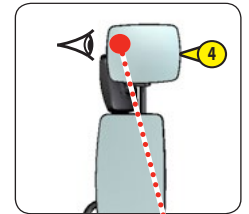
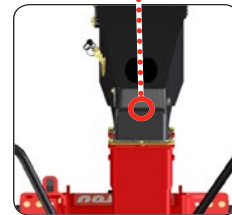
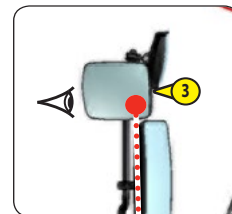
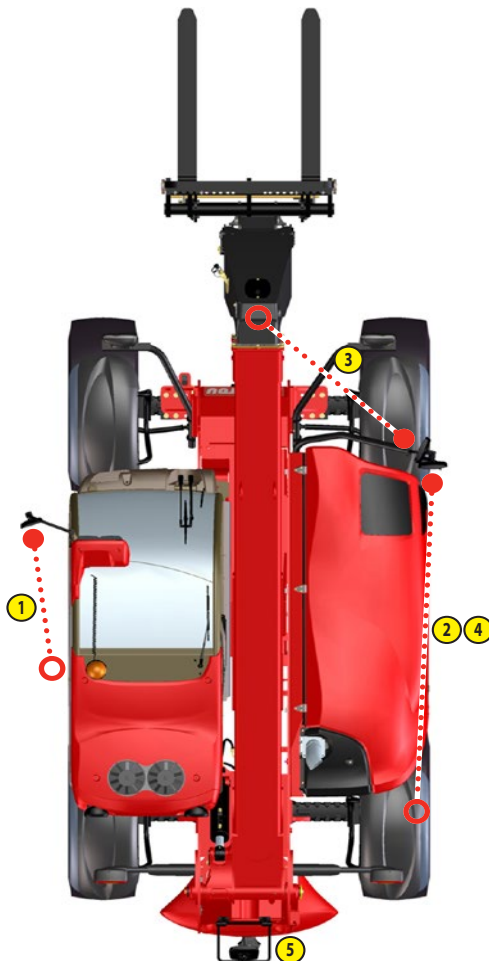
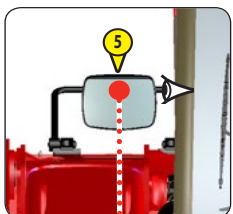
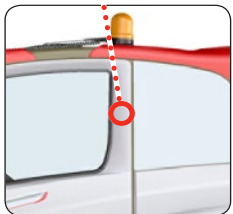
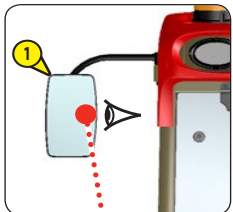
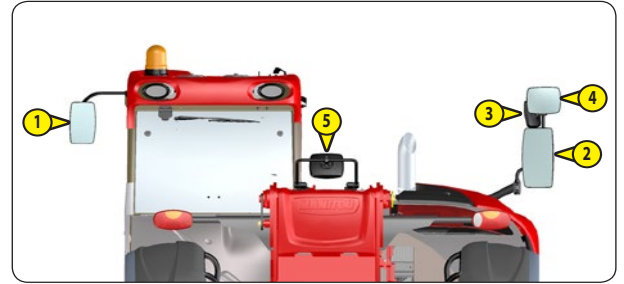

DIRECT AND/OR INDIRECT VISIBILITY BLIND SPOT ZONES

In accordance with EN15830, the two diagrams indicate blind spot zones on the visibility test circle (r 12m) and the 1m rectangular zone around the telehandler.

HANDLING SUSPENDED LOADS

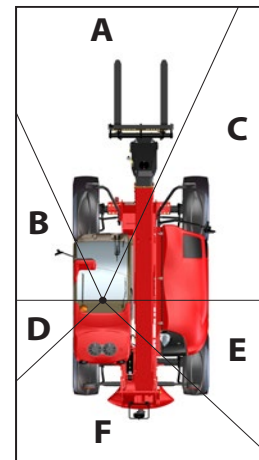
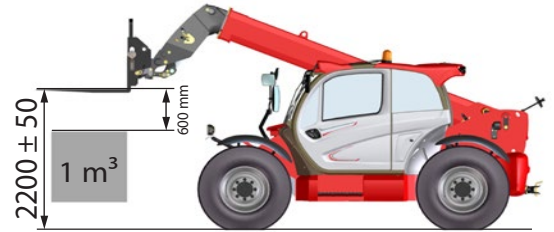
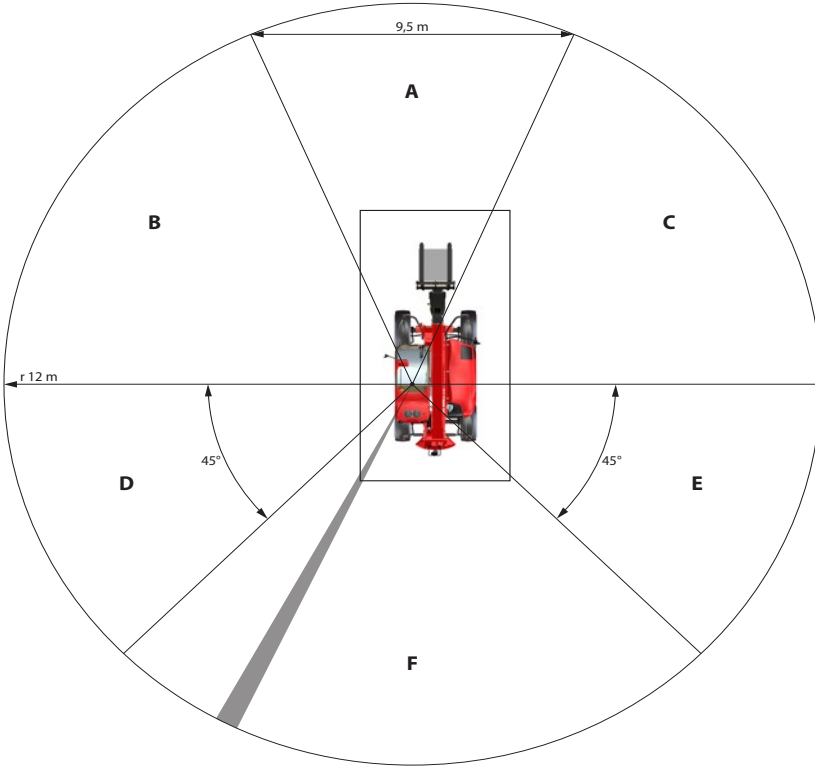

LOADING THE TRAILER

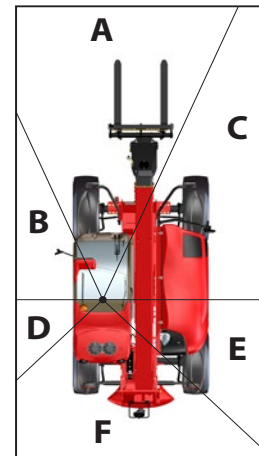
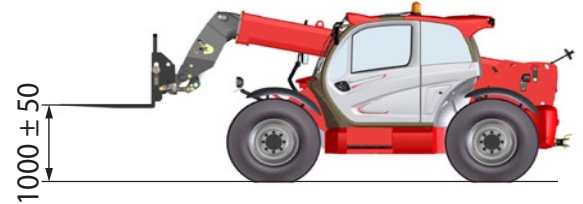
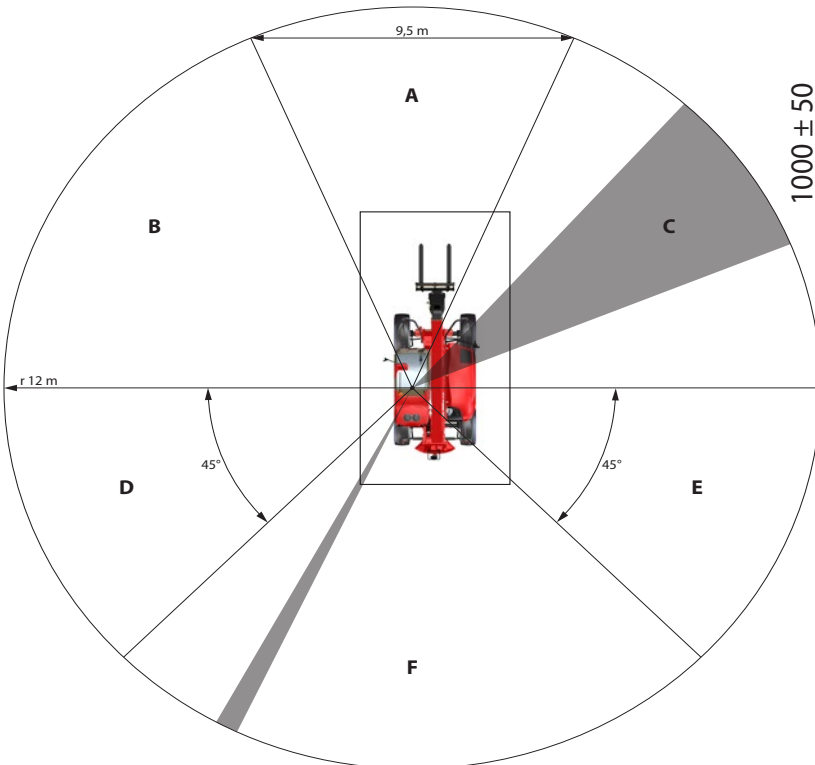

INSTRUMENTS AND CONTROLS

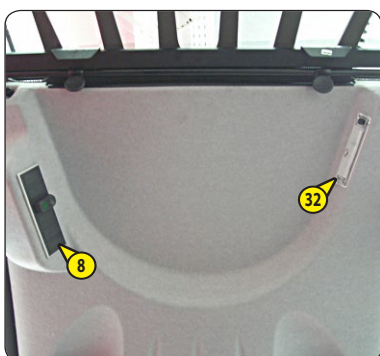
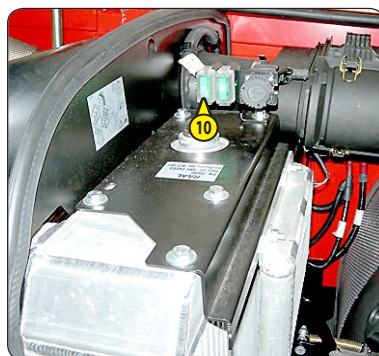
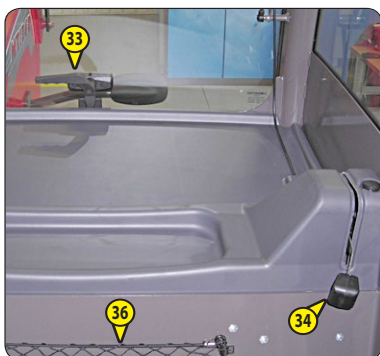
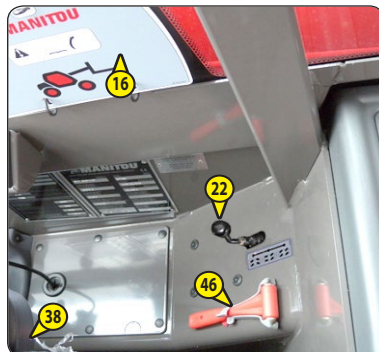
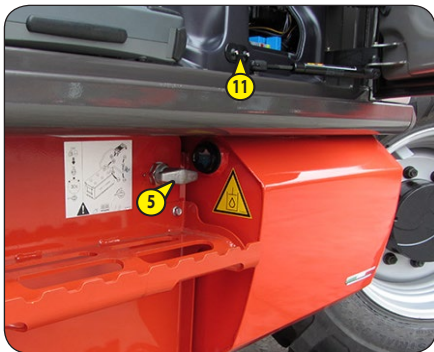



DESCRIPTION

1 - DRIVER'S SEAT	22
2 - SEAT BELT	24
3 - IGNITION SWITCH	24
4 - EMERGENCY STOP BUTTON	24
5 - BATTERY SWITCH	24
6 - HUMAN-MACHINE INTERFACE (HMI)	24
7 - LONGITUDINAL STABILITY SIGNALLING DEVICE	37
8 - SWITCHES	39
9 - FUSES AND RELAYS IN THE CAB	40
10 - FUSES AND RELAYS UNDER THE ENGINE BONNET	41
11 - DOOR PRESENCE SENSORS	42
12 - CIGARETTE LIGHTER	42
13 - LIGHTING, HORN AND INDICATOR LIGHTS	42
14 - FRONT AND REAR WINDSCREEN WIPER SWITCH	42
15 - FUNCTION CARDS	42
16 - HYDRAULIC CONTROLS	43
17 - ACCELERATOR PEDAL	44
18 - SERVICE BRAKE PEDAL	44
18a - INCHING PEDAL	44
19 - FORWARD/NEUTRAL/REVERSE GEAR SELECTION	44
20 - CVT TRANSMISSION AND DRIVING MODE	45
21 - I.C. ENGINE SPEED REGULATOR	46
22 - STEERING SELECTION	46
23 - HEATER CONTROL	47
24 - CAIR CONDITIONING CONTROLS (AIR CONDITIONING OPTION)	47
25 - HEATING VENTS	47
26 - DEMISTING VENTS	47
27 - LEVEL INDICATOR	48
28 - DOOR OPENING LEVER	48
29 - DOOR LOCKING HANDLE	48
30 - WINDOW SWITCH	48
31 - SIDE STORAGE COMPARTMENT	48
32 - CEILING LIGHT	48
33 - HANDLE FOR REAR WINDOW OPENING	48
34 - REAR WINDOW CLOSING LEVER	48
35 - STEERING WHEEL ADJUSTMENT KNOB	48
36 - DOCUMENT HOLDER	49
37 - STORAGE COMPARTMENT	49
38 - ARMREST ADJUSTMENT	49
39 - FRONT HEADLIGHTS	49
40 - REAR LIGHTS	49
41 - BEACON	50
42 - INTERNAL REAR VIEW MIRROR (OPTIONAL)	50
43 - BOOM SAFETY LOCK	50
44 - PLATE LIGHT	50
45 - PLATE	50
46 - EMERGENCY EXIT	50

NOTE: All the terms such as: RIGHT, LEFT, FRONT, REAR are meant for an observer seated on driver's seat and looking in front of him.

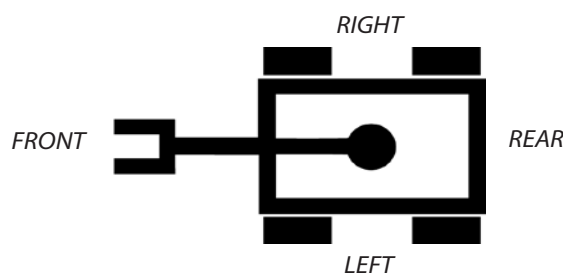

1 - DRIVER'S SEAT

DRIVER'S SEAT (STANDARD)

DESIGNED FOR MAXIMUM COMFORT, THIS SEAT CAN BE ADJUSTED AS FOLLOWS.

SEAT HEIGHT ADJUSTMENT

- Sit down correctly in the seat.
- Turn the knob 1 according to the desired height, clockwise to rise, anti-clockwise to lower, ensuring that the green indicator lamp 2 remains visible.
- If indicator lamp 2 is red, re-adjust the height.

NOTE: The seat is designed so as not to require adjustment according to the driver's weight.

LONGITUDINAL ADJUSTMENT

- Pull the locking lever 3 upwards.
- Slide the seat to the desired position.
- Release the lever and be sure it returns to the lock position.

ANGLE ADJUSTMENT OF THE BACK-REST

- Support the back-rest, push the lever 4 backward and tilt the back-rest to the desired position.

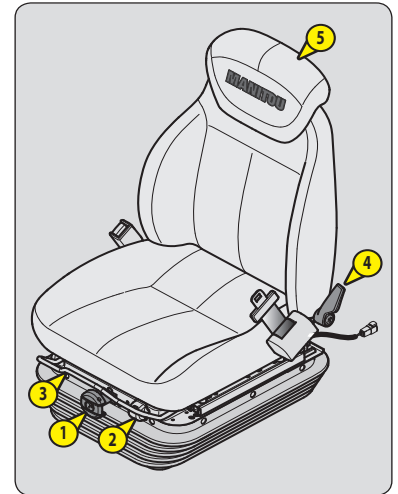

⚠ IMPORTANT ⚠

If you do not support the back-rest when making adjustments, it swings completely forwards.

EXTENDING THE HEAD-REST

- The height of the head-rest 5 can be adjusted by pulling it upwards (the notches will click) up to the stop.
- The head-rest can be removed by applying sufficient pressure to pull it off the stop.

LOW FREQUENCY DRIVER'S PNEUMATIC SEAT (OPTION)

DESIGNED FOR MAXIMUM COMFORT, THIS SEAT CAN BE ADJUSTED AS FOLLOWS.

SEAT HEIGHT ADJUSTMENT

- Sit down correctly in the seat.
- Switch on telehandler ignition.
- Pull or push lever 1 according to the desired height, making sure that the green indicator lamp 2 remains visible.
- If indicator lamp 2 is red, re-adjust the height.

NOTE: The seat is designed so as not to require adjustment according to the driver's weight.

LONGITUDINAL ADJUSTMENT

- Pull the locking lever 3 upwards.
- Slide the seat to the desired position.
- Release the lever and be sure it returns to the lock position.

ANGLE ADJUSTMENT OF THE BACK-REST

- Support the back-rest, push the lever 4 backward and tilt the back-rest to the desired position.

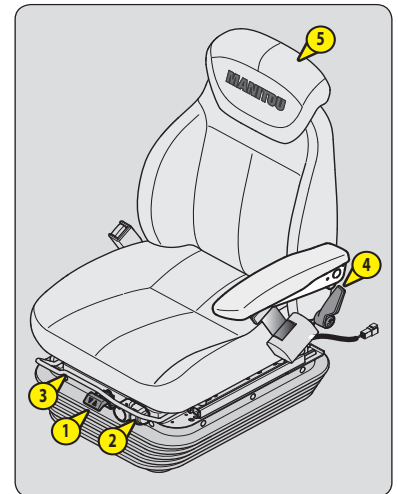

⚠ IMPORTANT ⚠

If you do not support the back-rest when making adjustments, it swings completely forwards.

EXTENDING THE HEAD-REST

- The height of the head-rest 5 can be adjusted by pulling it upwards (the notches will click) up to the stop.
- The head-rest can be removed by applying sufficient pressure to pull it off the stop.

DRIVER'S PNEUMATIC SEAT (OPTION)

DESIGNED FOR MAXIMUM COMFORT, THIS SEAT CAN BE ADJUSTED AS FOLLOWS.

SEAT HEIGHT ADJUSTMENT

- Sit down correctly in the seat.
- Switch on telehandler ignition.
- Pull or push lever 1 according to the desired height, making sure that the green indicator lamp 2 remains visible.
- If indicator lamp 2 is red, re-adjust the height.

NOTE: The seat is designed so as not to require adjustment according to the driver's weight.

LONGITUDINAL ADJUSTMENT

- Swing lever 3 upwards.
- Slide the seat to the desired position.
- Release the lever and be sure it returns to the lock position.

HORIZONTAL DAMPER

In certain conditions (e.g. driving with a trailer) it is advised that a horizontal shock absorber be used. The driver's seat is thus better able to absorb jerks in the direction of travel.

- Swing lever 3 downwards to block the horizontal damper.

ANGLE ADJUSTMENT OF THE BACK-REST

- Support the back-rest, push the lever 4 backward and tilt the back-rest to the desired position.

⚠ IMPORTANT ⚠

If you do not support the back-rest when making adjustments, it swings completely forwards.

EXTENDING THE HEAD-REST

- The height of the head-rest 5 can be adjusted by pulling it upwards (the notches will click) up to the stop.
- The head-rest can be removed by applying sufficient pressure to pull it off the stop.

LUMBAR ADJUSTMENT

- Turn knob 6 anti-clockwise to select one of the 5 lumbar support settings.

SEAT HEATING

- Switch 7 operates the heating of the seat cushion and the back-rest.

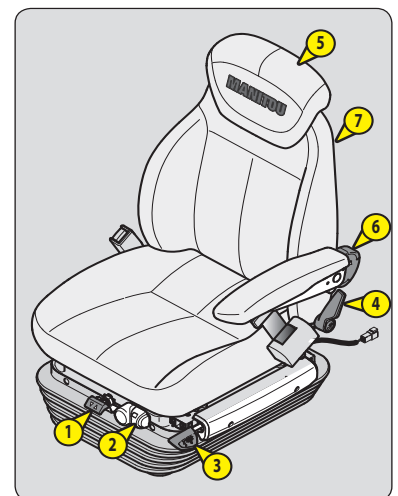



2 - SEAT BELT

⚠ IMPORTANT ⚠

*In no event should the telehandler be used if the seat belt is defective (fixing, locking, cuts, tears, etc.).
Repair or replace the seat belt immediately.*

- Sit correctly on the seat.
- Check that seat belt is not twisted.
- Place the seat belt at hip level.
- Attach the seat belt and check that it locks.
- Adjust the seat belt to your body shape without squeezing your hip and without over-slack.

3 - IGNITION SWITCH

The ignition switch has five positions:

- P - Not used.
- O - Ignition switched off and engine stopped.
- I - Ignition + preheating.
- II - Not used.
- III - The engine starts, return to position I as soon as the key is released.



4 - EMERGENCY STOP BUTTON

In case of danger, forces the transmission to neutral and cuts-off hydraulic movements.

⚠ IMPORTANT ⚠

*Warning, hydraulic movements suddenly stop when using this button.
If possible, stop the telehandler before using the emergency stop.*

- Turn the button to disable it.
- Restart the telehandler to restore the normal operating conditions.



5 - BATTERY CUT-OFF

For quickly disconnecting the battery when working on the electric circuit or when soldering, for example.

⚠ IMPORTANT ⚠

Operate the battery cut-off no less than 30 seconds after having switched off the ignition with the ignition key.



6 - MAN-MACHINE INTERFACE (MMI)

- 6A - DRIVER PRESENCE
- 6B - INSTRUMENT CONTROL PANEL
- 6C - PANEL FOR BUTTONS AND KEYBOARD
- 6D - SCREEN DISPLAY

UPDATED: In order to gain maximum advantage from the Man-Machine Interface of your telehandler, contact your dealer to receive the most recent available version of the software.



6A - DRIVER PRESENCE

The driver's presence is validated when the operator is correctly seated and the cab door is closed.

- It is only from that moment that the telehandler is operational; the operator can perform hydraulic movements and move the telehandler.

6B - INSTRUMENT CONTROL PANEL



A - REV COUNTER

B - FUEL LEVEL

When the yellow warning light B1 comes on it means that you are in reserve and that your running time is limited.

C - LONGITUDINAL STABILITY WARNING LIGHT

See: 2 - DESCRIPTION: 7 - LONGITUDINAL STABILITY LIMITER AND WARNING DEVICE.

D - FORWARD/NEUTRAL/REVERSE LIGHT

See: 2 - DESCRIPTION: 20 - FORWARD/NEUTRAL/REVERSE GEAR SELECTION.

E - GREEN STEERING LIGHTS

A continuous beeping sound on and off at the same time as the steering lights when using indicator lights or hazard warning lights.

F - GREEN WARNING LIGHTS FOR WHEEL ALIGNMENT

See: 2 - DESCRIPTION: 22 - STEERING SELECTION.

G - DIGICODE INDICATOR LIGHT

This light flashes when the digicode is enabled (see: 2 - DESCRIPTION: 6D - SCREEN DISPLAY).

H - ENGINE WATER LEVEL AND TEMPERATURE LIGHT

COLD ENGINE: If the H1 light comes on when the telehandler is running, this means that the cooling liquid level is too low. Immediately stop the engine and check the level.

HOT ENGINE: If the H1 light comes on when the telehandler is running, this means that the cooling liquid temperature is too high or its level is too low. Immediately stop the engine and seek the cause of the cooling system malfunction.



MAJOR FAULT WARNING LIGHT

When this light is on it indicates that there is a major fault that may affect the safety for the telehandler or the driver. Stop the telehandler and refer to the error codes (see: 2 - DESCRIPTION: 6D - SCREEN DISPLAY: MENU SCREEN).



GREEN LIGHT FOR LOW BEAM



BLUE LIGHT FOR MAIN BEAM



AIR FILTER CLOGGING LIGHT

The light comes on when the air filter cartridge is clogged up. When this light remains continuously lit the cartridge needs changing. Stop the telehandler and carry out the necessary repairs (see: 3 - MAINTENANCE: SERVICING SCHEDULE).



HYDRAULIC RETURN OIL FILTER CARTRIDGE CLOGGING LIGHT

The light comes on when the hydraulic return oil filter cartridge is clogged up. When this light remains continuously lit the cartridge needs changing. Stop the telehandler and carry out the necessary repairs (see: 3 - MAINTENANCE: SERVICING SCHEDULE).

NOTE: This light comes on by cold weather or when starting the fork telehandler, it goes off when the hydraulic oil reaches its operating temperature.



POWER-ASSISTED STEERING FAULT INDICATOR LIGHT

If the light comes on when the telehandler is running, stop the engine immediately and look for the cause (possible leak, etc.).



BRAKE FLUID LEVEL OR POWER-ASSISTED BRAKING FAULT INDICATOR LIGHT

If the light comes on, when the telehandler is running, stop the I.C. engine immediately and check the braking oil level. In the event of an abnormal drop in the level, consult your dealer.



HIGH EXHAUST GAS TEMPERATURE INDICATOR LIGHT

The light comes on while the telehandler is running to indicate a high exhaust gas temperature.



WATER IN FUEL PRE-FILTER LIGHT

This light will come on when there is water in the fuel pre-filter. Stop the telehandler and carry out the necessary repairs (see: 3 - MAINTENANCE: SERVICING SCHEDULE).



I.C. ENGINE AUTOMATIC PREHEATING LIGHT

This light comes on when the telehandler's ignition is switched on and should go out as soon as pre-heating is ended. If it comes on while the telehandler is in operation, immediately stop the I.C. engine and find the cause.



I.C. ENGINE OIL PRESSURE LIGHT

If the light comes on when the telehandler is running, stop the I.C. engine immediately and look for the cause (see oil level in I.C. engine crankcase).



I.C. ENGINE PREHEATING FAULT INDICATOR LIGHT

If the light comes on when the telehandler is running, stop the engine immediately and look for the cause (possible leak, etc.).

NOTE: This light comes on the moment the ignition key is in position I and until the engine is started.



BATTERY LOAD LIGHT

If this light comes on when the telehandler is running, switch off the I.C engine immediately and check the electric circuit and the alternator belt.



GREEN PROGRESSIVE INCHING TRANSMISSION MODE INDICATOR LIGHT

This light comes on when using the progressive transmission "INCHING" mode (see: 2 - DESCRIPTION: 6C - PANEL FOR BUTTONS AND KEYBOARD).



GEAR BOX OIL PRESSURE LIGHT

This light comes on when there is an abnormal drop in gear box pressure. Stop the telehandler and look for the cause (e.g., Low oil level in the transmission, internal leak in the transmission, etc.).



GEAR BOX OIL TEMPERATURE LIGHT

This light comes on when the temperature of the gear box oil is abnormally high. In this case, place the forward/reverse selector in neutral and let the I.C. engine running at idle for a few minutes. If the light remains on, stop the telehandler and contact your dealer.

NOTE: Abnormal heating of the oil may be linked to an incorrect use of the gear box ratios (see: 2 - DESCRIPTION: 21 - GEAR SELECTOR).



PARKING BRAKE LIGHT

This light comes on when the parking brake is applied.

A flashing light indicates a fault (see: 2 - DESCRIPTION: 6D - SCREEN DISPLAY: MENU SCREEN).



HYDRAULIC MOVEMENT NEUTRALISATION LIGHT

The lights when the hydraulic controls are neutralised and when a forbidden hydraulic movement is requested.

NOTE: When driving on the road, it is strongly recommended that you lock all hydraulic movements.

6C - PANEL FOR BUTTONS AND KEYBOARD



A beep is sounded each time one of the buttons is pressed.



"BUCKET" MODE

See: 2 - DESCRIPTION: 7 - LONGITUDINAL STABILITY LIMITER AND WARNING DEVICE.



"ECOMODE" MODE

See: 2 - DESCRIPTION: 21 GEAR MODE (diesel engine control)).



"SUSPENDED LOAD" MODE

See: 2 - DESCRIPTION: 7 - LONGITUDINAL STABILITY LIMITER AND WARNING DEVICE.



ATTACHMENT CIRCUIT

⚠ IMPORTANT ⚠

*By default, the attachment circuit in continuous mode is disabled as soon as the operator leaves the driver's cab.
This condition can be changed from the OPT menu on the menu screen.*



ATTACHMENT CIRCUIT UNLOCKED (by default)



ATTACHMENT CIRCUIT LOCKED

- It is recommended to use this function when the telehandler is not fitted with hydraulic attachment.





ATTACHMENT CIRCUIT IN CONTINUOUS MODE

- The  indicator will light when it is in use.

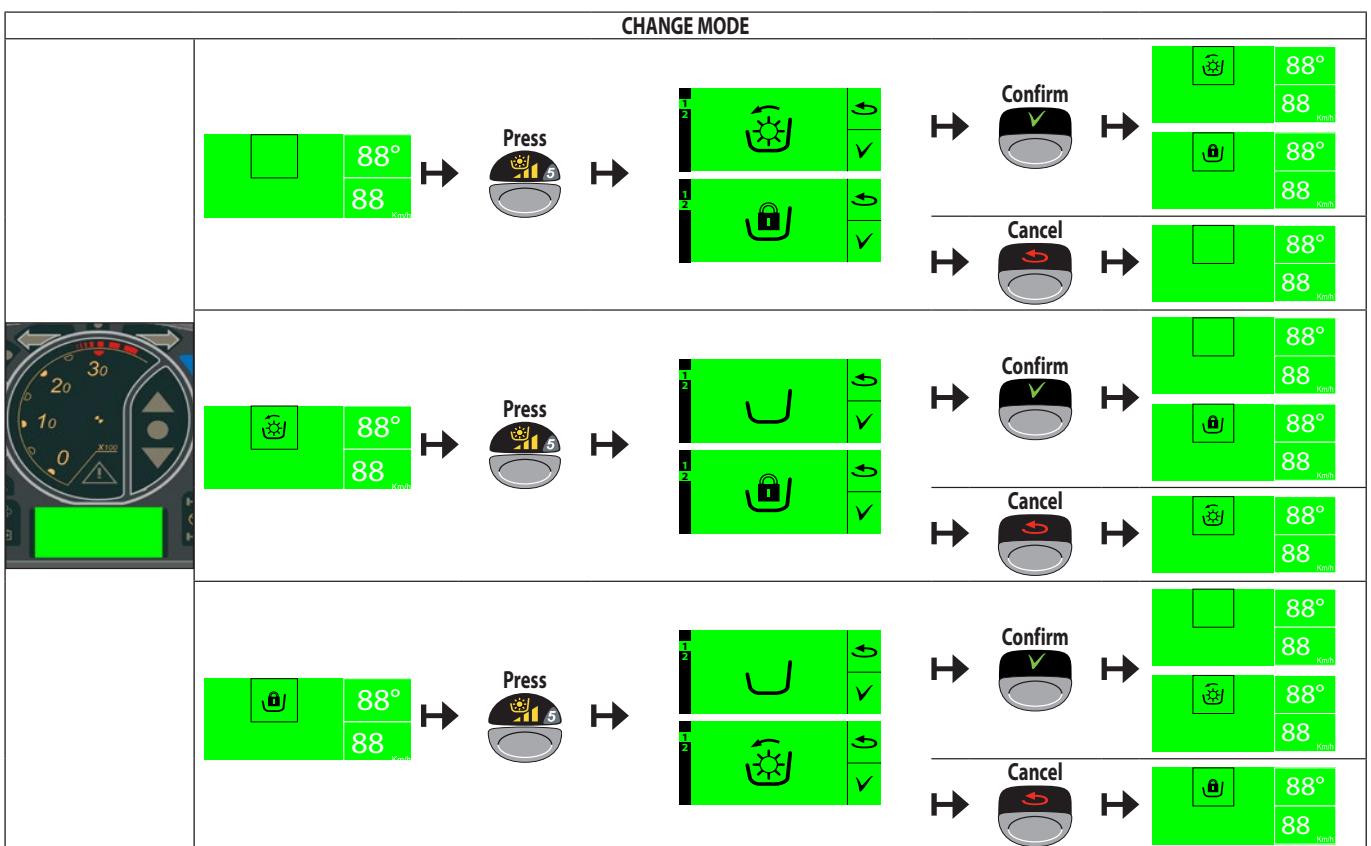
The operating screen displays the enabled mode. Press  or  or  button to display the other available mode(s).



ADJUSTING THE ATTACHMENT CIRCUIT HYDRAULIC FLOW RATE IN CONTINUOUS MODE

- The  pictogram flashes, and switches to the setting  screen as soon as hydraulic flow rate is selected using button A on the attachment hydraulic control lever.
- Button A forward for positive percentage (+ XX %), backward for negative percentage (XX %).
- Hold button A in the same position for 4 seconds to confirm the chosen hydraulic

flow rate 

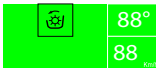
- Press the button  , or actuate button A, to return to the  screen with the flashing pictogram and thus disable continuous mode.
- Switches B and C limit the attachment hydraulic flow (see: 2 - DESCRIPTION: 17 HYDRAULIC CONTROLS).





OPTION BOOM SUSPENSION

See: 2 - DESCRIPTION: DESCRIPTION AND USE OF THE OPTIONS.



OPTION - ATTACHMENT EASY HYDRAULIC CONNECTION

See: 2 - DESCRIPTION: DESCRIPTION AND USE OF THE OPTIONS.



OPTION - REAR FOG LIGHT

Only works when the low beam or main beam lights are switched on. The indicator will light when in use.



OPTION - FRONT WORKING HEADLIGHTS



ROTATING BEACON LIGHT

NOTE: Except in case of emergency, it is advised to disable the rotating beacon light when the ignition is switched off to avoid a flat battery.



MENU SCREEN DISPLAY

A flashing light indicates a fault (see: 2 - DESCRIPTION: 6D - SCREEN DISPLAY: MENU SCREEN).



CANCEL OR BACK



CONFIRM



TESTING THE LONGITUDINAL STABILITY LIMITER AND WARNING DEVICE

See: 2 - DESCRIPTION: 7 - LONGITUDINAL STABILITY LIMITER AND WARNING DEVICE.



REVERSAL FAN

Cleans the radiator core and the grille of the engine cover by reversing the air flow.

The button is constantly lit as soon as automatic mode is activated.

⚠ IMPORTANT ⚠

When in use, beware of the risk of projection into the eyes.

- A short press on the button launches an individual fan reversal cycle.

- The  screen appears when there is insufficient time between two individual ventilation fan reversal cycle requests.

- Holding down the button launches the automatic fan reversal every 3 minutes, the  screen appears.

- A short press on the button stops the automatic fan reversal, the  screen appears.



HAND-OPERATED PARKING BRAKE

The hand-operated or automatic (by default) parking brake can be configured from the OPT menu in the menu screen.



HAZARD WARNING LIGHTS

This switch enables the L.H. and R.H. Indicators to be switched on simultaneously, with the ignition off.

NOTE: Except in case of emergency, it is advised to disable the hazard warning lights when the ignition is switched off to avoid a flat battery.



LOCKING HYDRAULIC CONTROLS



HYDRAULIC CONTROLS AVAILABLE (by default)



TILTING CONTROL LOCKED



HYDRAULIC CONTROLS LOCKED

• When driving on the road, it is strongly recommended that you lock all hydraulic movements.

Press or button to display the other available mode(s), the first screen displayed is the opposite of the enabled mode.

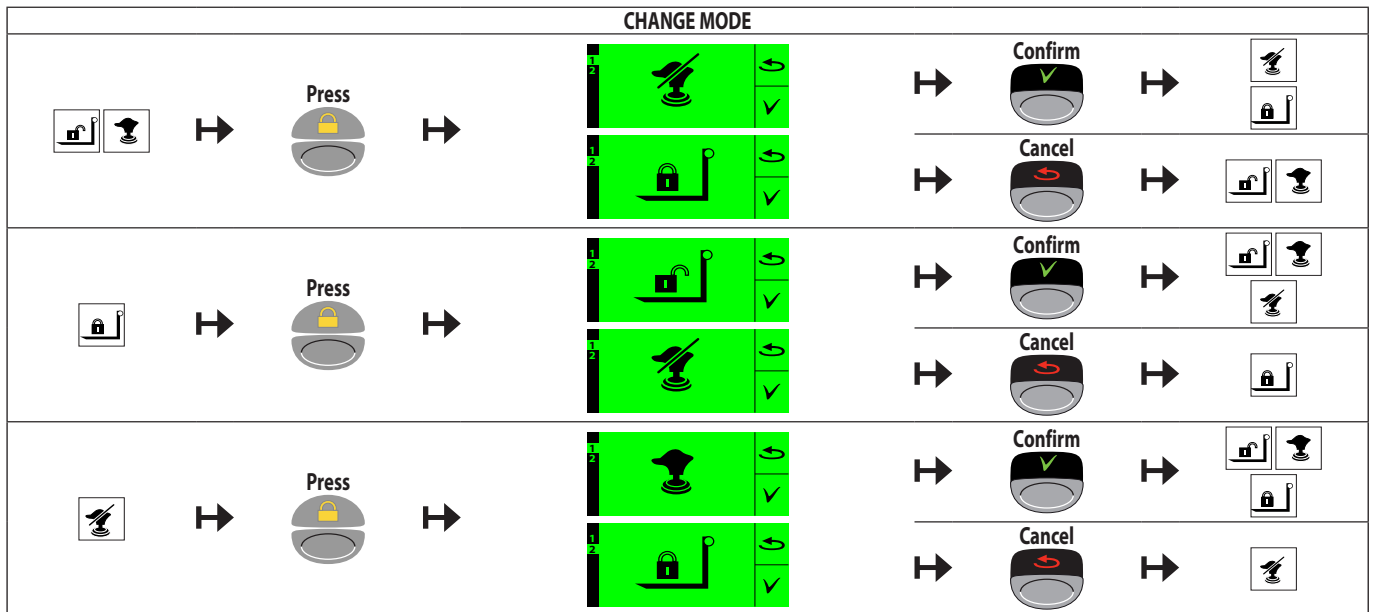

6D - SCREEN DISPLAY



SCREEN OFF

Lift truck parked, with ignition off and without the driver.



LOGO SCREEN

System initialising. A beep is sounded when this screen appears. If the screen remains permanently displayed, contact your dealer.

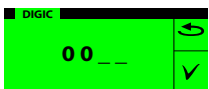

DIGICODE SCREEN

The digicode is disabled by default. It can be enabled from the OPT menu on the menu screen. A beep is sounded when this screen appears.

- Switch on the telehandler ignition. Enter the code (default 0000) using the keys on the keyboard and confirm with the

confirm button . Automatically moves to the next character.

NOTE: The code can be modified in the OPT menu (see: MENU SCREENS).



HOUR METER SCREEN

With the operator present in the cab and the electrical contact cut, the screen displays the total number of hours worked [888888h], the number of hours for that working day [888.88h] and the number of hours before the next major maintenance [888h].

RESETTING THE DAILY WORKING HOURS COUNTER BACK TO ZERO

- Authorization of this function can be configured from the OPT or XPRT menu (see: MENU SCREEN).

NOTE: Authorising this function can be configured from the OPT menu in the menu screen.

RESETTING THE MAINTENANCE COUNTER TO 500H

- Reset the maintenance counter to 500h from the XPRT menu (see: MENU SCREEN).

NOTE: The hour meter screen can be displayed as required by means of the  button from the operating display.

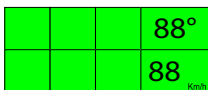

OPERATING SCREEN

The screen displays the telehandler's operating state (different screen for each operating mode).

1		DEF level indicator (fluid for exhaust gas after-treatment system) Flashing indicator: additive level < 10% (see: HELP SCREEN & FAULT SCREEN).
1		White screen.
		No function released and at least a function locked (see default screen).
		At least one function released (see default screen).
2		White screen.
		Attachment circuit locked.
		Flashing screen. Required attachment in continuous mode circuit not active.
		Steady screen. Attachment in continuous mode circuit active
3		White screen.
		Fault in the locking jack of the rear axle.
		Rear axle oscillation blocked. (see: 2 - DESCRIPTION: 8 - SWITCHES: "Machine travel reset").
		Flashing screen. Requested boom suspension not active
		Steady screen. Boom suspension active.

4		Lifting angle of the boom is degrees.
		Error of the lifting angle sensor (see: "MENU SCREEN" / XPRT / CALIB > BOOM)
5		White screen.
		Maintenance key.
6		White screen.
		Automatic regeneration of the exhaust particulate filter deactivated (see: 8 - SWITCHES).
		High or very high soot level (see: 8 - SWITCHES).
		Exhaust gas after-treatment system fault (see: HELP SCREEN & FAULT SCREEN)
7		White screen.
		Transmission blocked in neutral, presence of operator not confirmed.
		OPTIONAL Transmission mode with "progressive movement" for forward and reverse gear.
		Forktelehandler travelling speed in km/h.
8		Forktelehandler travelling speed sensor fault (contact the dealer).
		Not used
		Not used



HELP SCREEN

One of these screens appear to inform the operator about the operations to be performed in the current configuration; when this screen is displayed, a buzzer beeps.

	Maintenance required (see: 3 - MAINTENANCE: D - EVERY 500 HOURS OF SERVICE).
	Next maintenance in hours (see: 3 - MAINTENANCE: D - EVERY 500 HOURS OF SERVICE).
	Close the door.
	Excessive speed.
	Excessive speed.
	Lower the boom.
	Use the attachment in continuous mode circuit and indication of the hydraulic flow.
	Set the gear selector to neutral again.
	Defective indicator light.
	Computer overheated (Contact your dealer).
	Computer fault (Contact your dealer).
	Operator presence not detected (see: 2 - DESCRIPTION: 6 - HUMAN-MACHINE INTERFACE (HMI)).
	Parking brake engaged.
	Depressurisation of the hydraulic attachment in progress.
	Depressurisation of the hydraulic attachment in progress.
	Interval between two requests of single cycles of fan inversion too short.
	Fan reversal automatic mode deactivated.
	Fan reversal automatic mode activated.
	Low fuel level.
	Ventilation fault (Contact your dealer).

	High soot level in automatic regeneration mode of the exhaust particulate filter active (see: 2 - DESCRIPTION: 8 - SWITCHES).
	High soot level in automatic regeneration mode of the exhaust particulate filter inactive (see: 2 - DESCRIPTION: 8 - SWITCHES).
	Moderate soot level in automatic regeneration mode of the exhaust particulate filter active (see: 2 - DESCRIPTION: 8 - SWITCHES).
	Moderate soot level in automatic regeneration mode of the exhaust particulate filter inactive (see: 2 - DESCRIPTION: 8 - SWITCHES).
	Regeneration of the exhaust particulate filter with "parked telehandler" in progress (see: 3 - MAINTENANCE: 1 - OCCASIONAL MAINTENANCE).
	Unsatisfactory condition for regeneration of the exhaust particulate filter with "parked telehandler" in progress (see: 3 - MAINTENANCE: OCCASIONAL MAINTENANCE).
	The activation request for the working mode or the request to save the "Working Mode" settings is impossible
	Automatic regeneration of the exhaust particulate filter active (see: 2 - DESCRIPTION: 8 - SWITCHES).
	Automatic regeneration of the exhaust particulate filter inactive (see: 2 - DESCRIPTION: 8 - SWITCHES).
	The level of DEF is low (see the next paragraph: SCR system DERATING).
	Exhaust gas emission control system and SCR system derating: Level 1 (see the next paragraph: SCR system DERATING).
	Machine tilted to the side by more than $\pm 3^\circ$ (see: 2 - DESCRIPTION: 8 - SWITCHES: "Machine travel reset")
	Machine tilted to the front by more than $\pm 4^\circ$
	Speed limited to ± 1 km/h. (see: 2 - DESCRIPTION: 8 - SWITCHES: "Machine travel reset")
	The activation request for the working mode or the request to save the "Working Mode" settings is impossible. It's impossible to save the "Working Mode" settings as the engine speed is too low or too high
	The "Working Mode" is ready for activation



FAULT SCREEN

⚠ IMPORTANT ⚠

In all cases stop the telehandler and contact the dealer.

By default, the operation cannot unlock functions (see: 2 – DESCRIPTION: 6D - DISPLAY: MENU SCREEN).

One of these screens appears when the system detects a malfunction of the telehandler; when this screen appears, an alarm sounds.

These malfunction conditions prevent access to some functions to ensure safety. However the operator can, under his own responsibility (and/or under the responsibility of the plant manager), remove the block to make the operation of the telehandler safer (e.g. unlocking the fault condition of the hydraulic valve to withdraw and lower the boom).

This unlock remains temporarily active, the function is locked again when power supply to the I.C. engine is cut off.

	Forbidden boom lifting fault.
	Hydraulic control fault.
	Fuel indicator fault.
	Exhaust particulate filter clogged fault.
	Exhaust gas emission control system and SCR system derating: Level 2 (See next paragraph: SCR SYSTEM DERATING).
	Transmission issue.
	Direction fault.
	Parking brake fault.

UNLOCKING THE FUNCTION (if authorised)

- Validate with button  to unlock the fault.

		Lock/unlock transmission fault.
		Lock/unlock hydraulic control fault.
		Lock/unlock parking brake fault.



SCR SYSTEM DERATING (CHECKING THE EMISSIONS OF EXHAUST GAS)

The DEF and SCR systems of the Final Tier 4 engines must decrease the emissions of NOx generated by the engine. If there are issues of some components of these systems, the NOx emissions increase, therefore the engine is no longer compliant with emission regulations. To ensure full conformity of the engine with the emission regulations, a specific program of derating has been designed for the faults pertaining to the DEF/SCR systems. In fact, faults may occur that do not allow the ECU to determine whether the system is operating correctly, therefore the ECU stops the DEF dosing system. When this condition occurs, a warning is displayed and an internal counter starts. The engine continues to operate normally even if the DEF dosing system is not operating, but the NOx emission rate is not compliant.

When the internal counter reaches 4 hours, the system activates a derating limiting torque to 50% and engine speed to the minimum idle unladen for a period of 10 minutes. This operation actually prevent the engine from operating as expected. After the DTC** that caused the activation of the counter is cleared, it stops and the performance of the engine is reset if derating had occurred. However if another DTC** stopping the DEF dosing system occurs, the counter restarts from the value that was reached when the previous DTC** was cleared. In order to reset the internal counter, the engine must operate for 40 hours without generating any DTC** stopping the DEF dosing system. If a DTC** is generated within these 40 hours, the counter resumes from the last reached value.

The following is a list of DTC* that deactivate the DEF dosing system and activate the derating time.

*: DTC = Type of malfunction errors of the I.C. engine

** : Check the DTC error codes of the I.C. engine, with reference to the following paragraph: MENU SCREEN, DIAG point".

⚠ IMPORTANT ⚠
Contact your agent or dealer.

DTC* LIST
Faults
Fluid level signal in the DEF tank higher than the maximum limit
Fluid level signal in the DEF tank lower than the minimum limit
Fluid temperature signal in the DEF tank higher than the maximum limit
Fluid temperature signal in the DEF tank lower than the minimum limit
Loss of communication with after-treatment inlet NOx sensor
Fault of the after-treatment inlet NOx sensor
Loss of communication with after-treatment outlet NOx sensor
Fault of the after-treatment outlet NOx sensor
DEF dosing injector signal higher than the maximum limit
DEF dosing injector signal lower than the minimum limit
High resistance in the DEF dosing injector circuit
Low resistance in the DEF dosing injector circuit
Invalid DEF dosing injector position
Extremely high pressure of the DEF dosing unit
Extremely low pressure of the DEF dosing unit
DEF dosing unit pressure signal higher than the maximum limit
DEF dosing unit pressure signal lower than the minimum limit
DEF dosing unit pressure signal fault
Moderately high pressure of the DEF dosing unit
Moderately low pressure of the DEF dosing unit
Error of the DEF dosing unit pressure
High resistance in the DEF dosing unit delivery pipe heating circuit
Low resistance in the DEF dosing unit delivery pipe heating circuit
High resistance in the DEF dosing unit delivery pipe heating circuit
Low resistance in the DEF dosing unit delivery pipe heating circuit
High resistance in the DEF dosing unit return pipe heating circuit
Low resistance in the DEF dosing unit return pipe heating circuit
SCR inlet temperature error
Extremely low efficiency of SCR conversion
High resistance in the DEF tank heater coolant control valve circuit
Low resistance in the DEF tank heater coolant control valve circuit
DEF tank heater coolant control valve locked open
DEF tank heater coolant control valve locked closed
High resistance in the DEF dosing unit inversion valve circuit
Low resistance in the DEF dosing unit inversion valve circuit
Low resistance in the DEF dosing unit pump circuit
DEF dosing unit pump circuit error
DEF dosing unit pump motor faulty
DEF dosing unit pump error
Loss of communication in the SCR temperature module
High resistance in the DEF dosing unit heating circuit
Low resistance in the DEF dosing unit heating circuit
Moderately low DEF dosing unit heater temperature



Diesel exhaust fluid (DEF) level.

The DEF level indicator is proportional and is shown on the display by four segments; each segments equals the DEF level status (approx. 25%, 50%, 75% and 100%).

If the DEF level is lower than 10%, a warning is issued and the engine torque decreases by 25%.

If there is no DEF additive:

- power is decreased by 50%,
- the engine speed decreases by 100 rpm per minute until reaching the minimum idle speed.

Overview:

DEF LEVEL INDICATOR						
Warning			Description			
						DEF level: OK
				-		DEF level: low
						DEF level: depleted

Warnings and indicators for the DEF level status and relevant SCR derating.





Overview:

SCR DERATING							
DEF level	Indicators			Consequences			
Warning							
Limitation to diesel emissions: 1					-		Engine performance limitations: - 50% decrease of torque, - 50% decrease of engine speed.
Restrizione per emissioni diesel: 2							Engine performance limitations: - 50% decrease of torque, - engine speed decreased to idling.

(*): A buzzers sounds for 2 seconds every time the status for SCR derating changes.



MENU SCREEN

- Press the button  to display the menu screen with the time and date. Navigate horizontally between menus using the buttons   and vertically in the sub-menus using the buttons  .

INFO

- Time and date (by default).
- Lift truck in degraded mode and/or fault detected (see error code table).
- “Check Maintenance” appears for a few seconds if maintenance is necessary.

FUEL

- RATE: Instantaneous consumption.
- AUTO: Fuel autonomy.
- DAILY: Daily consumption and average consumption.

(validate with the  button to reset consumption back to zero).

CLOCK

- HOUR: Change the hour
- DATE: Change the date
- FORM: Change the time or date format.

LCD

- BACKL: Backlight.
- CONTR: Contrast.

OPT

The contents of this menu can be accessed by means of a customer password with the engine switched off.

- RST H: Resetting of daily hour counter to zero, permitted (by default) or not permitted.
- PARK: Hand-operated parking brake or automatic (by default).
- CFLOW: Forced operation without driver presence permitted or not permitted (by default).
- LLMC: Disabling of aggravating hydraulic movement cut-off permitted (by default) or not permitted.
- PASS: Fault override permitted or not permitted (by default).
- UNIT: Speed of travel displayed in MPH or Km/h (by default).
- DIGI1: Digicode enabled or not enabled (by default).
- DIGI2: Change the 4 figure digicode (telehandler start-up).
- CUST: Change the customer code.
- STOP: it enables or disables the automatic engine stop when the option is available.

DIAG

The contents of this menu enable your dealer to perform diagnostics on the Man-Machine Interface.

XPRT

- RESET > HOURM: Reset the daily hour meter to zero.
MAINT: Reset the maintenance interval to 500 hours.
- ADMIN > ADMIN: Change the administrator code.
- ERASE > MC: Clear faults from the computer of the Man-Machine Interface.
MP1: Clear faults from computer MP1.
MP2: Clear faults from computer MP2.
- CALIB > SECU: Calibration of boom angle and strain gauge.
GAUGE: Recalibration of strain gauge.
BOOM: Calibration of boom angle.
MT HR: IC engine speed regulator calibration.
BRAKE: Brake pedal calibration.
- INCLI > Calibration of the inclinometer.



7 - LONGITUDINAL STABILITY LIMITER AND WARNING DEVICE

Depending on the model of telehandler

⚠ IMPORTANT ⚠

The operator must respect the telehandler's load chart, and the operating mode according to the attachment.

This device warns the operator of the telehandler's longitudinal stability limits. However, lateral stability can reduce the load chart in the upper part, and this reduction is not detected by the device.

Depending on the type of work required, the longitudinal stability limiter and warning device allows the operator to operate the telehandler in complete safety.

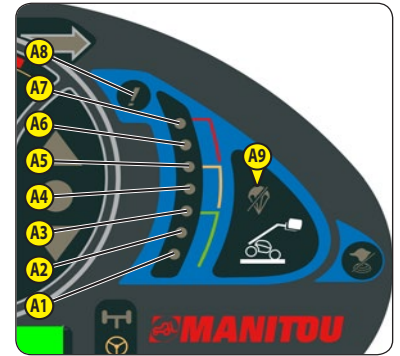

IDENTIFICATION OF YOUR SETTINGS

CONFIGURATION 1	Warning light A9 is lit when driving.
CONFIGURATION 2	"BUCKET" mode is disabled when the telehandler is at a standstill.



"HANDLING" MODE

USE ON FORKS

CONFIGURATION 1

By default, the device is in "HANDLING" MODE when the telehandler is started-up, except if "BUCKET" MODE has been selected before switching off the ignition.

Protection against forward tip-over when making aggravating movements is ensured, except when the telescopic boom is retracted and/or the telehandler is moving.

DEVICE STATUS			
HALTED	SLOW SPEED 1 to 5 km/h	SPEED > 5 km/h	TELESCOPE(S) IN RETRACTED POSITION
A4-A5: Very slow intermittent sound alarm. A6: Slow intermittent sound alarm. A7: Fast intermittent sound alarm. A8: Very fast intermittent sound alarm.	A7: Fast intermittent sound alarm. A8: Very fast intermittent sound alarm. - Warning light A9 lit.	- No sound alarm. - Warning light A9 lit.	- No sound alarm.  - Warning light A9 lit.

CONFIGURATION 2

By default, the device is in "HANDLING MODE" each time the telehandler is started.

Protection against forward tip-over when making aggravating movements is ensured, except when the telescopic boom is retracted.

DEVICE STATUS			
HALTED	SLOW SPEED 1 to 5 km/h	SPEED > 5 km/h	TELESCOPE(S) IN RETRACTED POSITION
A4-A5: Very slow intermittent sound alarm. A6: Slow intermittent sound alarm. A7: Fast intermittent sound alarm. A8: Very fast intermittent sound alarm.	A7: Fast intermittent sound alarm. A8: Very fast intermittent sound alarm.	- No sound alarm.	- No sound alarm.  - Warning light A9 lit.



"BUCKET" MODE

USE WITH BUCKET

CONFIGURATION 1

- Place the telehandler in the transport position.

- Press the  button, "BUCKET" MODE is confirmed by an audible beep and the lighting of the indicator lamp.
- Press this button again to return to "HANDLING" MODE.
- Protection against forward tip-over when making aggravating movements is ensured, except when the telescopic boom is retracted and/or the telehandler is moving.

NOTE: "BUCKET" MODE remains enabled as long as the mode is not changed by the operator, even after switching off the ignition.

DEVICE STATUS			
HALTED	SLOW SPEED 1 to 5 km/h	SPEED > 5 km/h	TELESCOPE(S) IN RETRACTED POSITION
A6: An audible signal on passing into the red zone.	A6: An audible signal on passing into the red zone. - Warning light A9 lit.	- No sound alarm. - Warning light A9 lit.	- No sound alarm.  - Warning light A9 lit.

CONFIGURATION 2

- Place the telehandler in the transport position.

- Press the  button, "BUCKET" MODE is confirmed by an audible beep and the lighting of the indicator lamp.
- Press this button again or switch off the ignition with the ignition key to return to "HANDLING" MODE.
- Protection against forward tip-over when making aggravating movements is ensured, except when the telescopic boom is retracted.

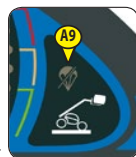
DEVICE STATUS			
HALTED	SLOW SPEED 1 to 5 km/h	SPEED > 5 km/h	TELESCOPE(S) IN RETRACTED POSITION
- "BUCKET" mode is disabled if the telehandler remains stationary.	A6: An audible signal on passing into the red zone. - Hydraulic movements are adjusted.	No sound alarm. - Hydraulic movements are adjusted.	- No sound alarm.  - Warning light A9 lit.

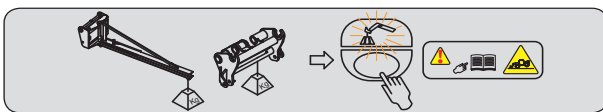

"SUSPENDED LOAD" MODE

USE WITH HOIST (offering a higher safety margin)

- Place the telehandler in the transport position.

- Press the  button, the "SUSPENDED LOAD" MODE is confirmed by a beep and the lighting of the indicator lamp. Hydraulic tilting movements are disabled, as well as the lifting movement when the longitudinal stability limit is reached (indicator lamp A8 lit).
- Press this button again or switch off the ignition with the ignition key to return to "HANDLING" MODE.
- Protection against forward tip-over when making aggravating movements is ensured, except when the telescopic boom is retracted.

CONFIGURATION 1 and 2

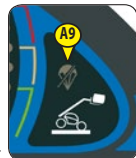
DEVICE STATUS			
HALTED	SLOW SPEED 1 to 5 km/h	SPEED > 5 km/h	TELESCOPE(S) IN RETRACTED POSITION
	A4-A5: Very slow intermittent sound alarm. A6: Slow intermittent sound alarm. A7: Fast intermittent sound alarm. A8: Very fast intermittent sound alarm.		- No sound alarm.  - Warning light A9 lit.

A - VISUAL ALARMS

- A1 - A2 - A3: There is a significant reserve of longitudinal stability.
- A4 - A5: The telehandler is approaching the limit of longitudinal stability, move with care.
- A6: The telehandler is close to the limit for longitudinal stability. Drive carefully.
- A7: The telehandler is very close to the limit of longitudinal stability. Manoeuvre with extreme caution.
- A8: The telehandler is at the authorised limit of longitudinal stability.

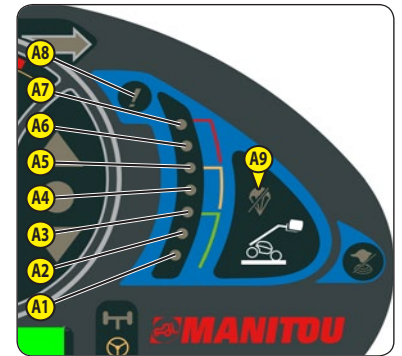

B - HYDRAULIC MOVEMENT CUT-OFF

"HANDLING" MODE

- A8: All "AGGRAVATING" hydraulic movements are cut-off. Only perform de-aggravating hydraulic movements in the following order: retract and raise the boom.

"BUCKET" MODE

- A8: The boom lowering and extension movements are cut-off, the other movements remain available.

"SUSPENDED LOAD" MODE

- A8: All "AGGRAVATING" and boom raising hydraulic movements are cut off. Only the boom retraction hydraulic movement is available.

C - DISABLING "AGGRAVATING" HYDRAULIC MOVEMENT CUT-OFF Second equipment (D1 ou D2)



Be extremely alert during this manoeuvre: the operator is informed exclusively from the dynamic stability of the truck.

Authorization of this function can be configured from the OPT menu in the menu screen.

In certain cases, in order to get out of a difficult situation, the operator can bypass this safety system. Selector C1 and C2 temporarily disables the cut-off of "AGGRAVATING" hydraulic movements..

Keep pressed the selector C1 or keep rotated the selector C2 (timer of 60 seconds), indicator lamp A9 lamp will light, and at the same time perform the necessary "AGGRAVATING" hydraulic movement with extreme care.



D - TESTING OF THE LONGITUDINAL STABILITY LIMITER AND WARNING DEVICE



- Short press the  button to verify at any time that the longitudinal stability alarm is working.
- Correct operation: All the LEDs A1 to A8 light for two seconds and an audible beep is sounded.

NOTE: This test does not check the proper adjustment of the longitudinal stability limiter that must be inspected daily or after every 10 hours of service (see: 3 - MAINTENANCE: A - DAILY OR EVERY 10 HOURS SERVICE).

E - STRAIN GAUGE



Disassembly or calibration of the strain gauge is prohibited, this must only be done by specially trained personnel, consult your dealer.

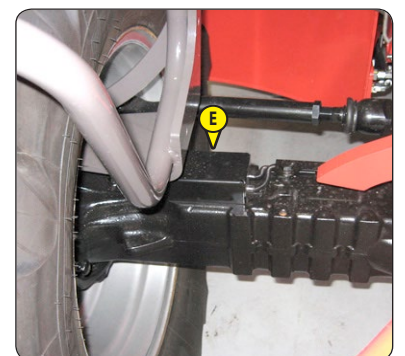



8 - SWITCHES

A - OPTION REAR WORKING LIGHTS

B - OPTION WORKING LIGHTS ON TELESCOPE

C - ROOF WINDSCREEN WIPER AND WINDSCREEN WASHER

This switch, when set in the “high” position, allows the windscreen wiper to be worked and with the “down” position pressed, the windscreen washer to be operated.

D - OPTION FOR SIDE WINDSHIELD WIPER AND WINDSHIELD WASHER

This switch, when set in the “high” position, allows the windscreen wiper to be worked and with the “down” position pressed, the windscreen washer to be operated.

E - OPTION REAR WINDOW DE-ICING

F - OPTION

G - 2°/3° HYDRAULIC EXIT SWITCH (OPTIONAL)

See: 2 - DESCRIPTION: DESCRIPTION AND USE OF THE OPTIONS.

H - OPTION BOOM HEAD ELECTRICAL PROVISION

I - OPTION

J - EXHAUST PARTICLE FILTER REGENERATION

- J1: DISABLE AUTOMATIC REGENERATION
- J2: “STATIONARY TELEHANDLER” REGENERATION
(see: 3 - MAINTENANCE: I2 - “STATIONARY TELEHANDLER” EXHAUST PARTICLE FILTER)

J1: DISABLE AUTOMATIC REGENERATION

⚠ IMPORTANT ⚠

Disabling automatic regeneration of the exhaust particle filter is a function that is only to be used in case of necessity (confined or unventilated space, etc.).

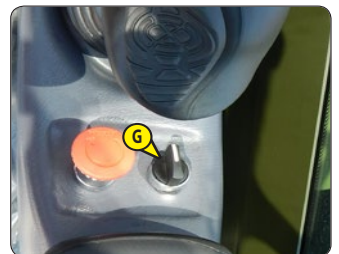
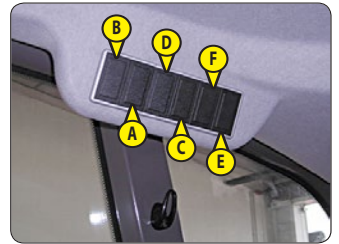

By default, exhaust particle filter automatic regeneration is enabled each time the telehandler is started.

- To disable automatic regeneration of the exhaust particle filter, hold down the bottom of the switch. The temporary display of the screen and an audible beep followed by the screen on the operating display confirm that it has been disabled.
- To re-enable automatic regeneration of the exhaust particle filter, hold down the bottom of the switch again. The temporary display of the screen and an audible beep confirm that it has been re-enabled.

MANAGEMENT OF EXHAUST PARTICLE FILTER REGENERATION	
INDICATIONS	ACTIONS
+ 1 short beep Moderate soot level.	The screen appears on the operating display, the switching on of the indicator light and the speeding up of the engine idling speed indicates that automatic regeneration is in progress. NOTE: Preferably wait until automatic regeneration is completed before switching off the ignition.
+ 1 short beep Moderate soot level, automatic regeneration disabled.	Enable automatic regeneration at the earliest possible time.
+ + 1 long beep High soot level.	Reduced telehandler efficiency, only “stationary telehandler” regeneration can be performed (see: 3 - MAINTENANCE: OCCASIONAL MAINTENANCE).
+ + 1 long beep High soot level, automatic regeneration disabled.	
+ + 1 short beep Very high soot level, particle filter clogged.	<p>Reduced telehandler efficiency, shut down the telehandler and contact your dealer.</p>



K - MACHINE TRAVEL RESET BUTTON



The forklift can be moved by pressing the "K" button only in exceptional cases and due to safety reasons.

In these conditions

- upper boom tilting angle more than 50°,
- lateral and/or front machine tilting more than ±3°
- front/rear (F/R) machine travel speed = 0 km/h,



the safety systems stops the rear axle oscillation , preventing the front-rear (F/R) travel of the machine.

When the "K" button is pressed, all front/rear (F/R) movements of the machine are allowed at low speed (1 km/h) and for a maximum of 5 seconds.



L - SELECTOR FOR THE EXCLUSION OF THE DEVICE FOR LONGITUDINAL STABILITY LIMITER

Second equipment (L1 or L2)

See: 2 - DESCRIPTION: 7 – SIGNALER DEVICE AND LONGITUDINAL STABILITY LIMITER.

9 - FUSES AND RELAYS IN THE CAB

A sticker on the inside of the access panel gives a clear display of the use of the components described below.

- Remove access panel 1 to gain access to the fuses and relays, Replace a used fuse with a new fuse of the same quality and capacity. Never reuse a repaired fuse.



RELAYS

- K1 - OPTION Automatic wheel alignment.
- K2 - Front windshield wiper intermittence relay.
- K3 - OPTION.
- K4 - OPTION Front working lights.
- K5 - Transmission control unit power supply time delay relay.
- K6 - Air conditioning relay.

MINIFUSE

- F1 - Front working headlights (15A).
OPTION xenon front working headlight (20A).
- F2 - Free.
- F3 - OPTION Rear hydraulic control switch power supply (2A).
- F4 - Heating and ventilation (20A).
- F5 - Disabling "AGGRAVATING" hydraulic movement cut-off + seat switch (2A).
- F6 - OPTION Electrical predisposition on telescope head (15A).
- F7 - OPTION Immobiliser (2A).
- F8 - OPTION Pneumatic seat (15A).
- F9 - Ignition (2A).
- F10 - OPTION Car radio (2A).
- F11 - Cigarette lighter (10A).
- F12 - Front windscreen wiper and windscreen washer (15A).
- F13 - Rear windscreen wiper and windscreen washer (10A).

F46		F40		F30		20A	F20		15A	F10		2A		
F45		F39		F29			F19		7.5A	F9		2A		
F44		F38		F28		5A	F18		15A maxi	F8		15A		
F43		F37		F27		15A	F17		15A	F7		2A		
F42		F36		F26		7.5A	F16		15A maxi	F6	OPT.	15A maxi		
F41		F35	LSU	F25		2A	F15		15A maxi	F5		2A		
		F34		F24		15A	F14			F4		2A		
		F33		F23		15A	F13		10A	F3	OPT.	2A		
		F32		F22		3A	F12		15A	F2		15A maxi		
		F31		F21		3A	F11		10A	F1		20A		
N°306360														



- F14 - OPTION.
- F15 - OPTION.
- F16 - OPTION Working lights on telescope (15A).
- F17 - OPTION Rear working light (15A).
- F18 - OPTION Rear window de-icing (15A).
- F19 - OPTION Roof windscreen wiper and windscreen washer (7,5A).
- F20 - Window winder (15A).
- F21 - Roof light + door switch (3A).
- F22 - Man-Machine Interface (MMI) (3A).
- F23 - Transmission computer power supply (15A).
- F24 - Front windscreen wiper motor (15A).
- F25 - OPTION Immobiliser (2A).
- F26 - OPTION Car radio (7,5A).
- F27 - Rear windscreen wiper motor (10A).
OPTION Roof windscreen wiper motor (10A).
OPTION Roof windscreen wiper motor + side windscreen wiper motor (15A).
- F28 - Diagnostic socket (5A).
- F29 - OPTION.
- F30 - OPTION Air conditioning compressor + fan (20A).
- F31 - Engine electronic control unit alert (5A).
- F32 - OPTION Side windscreen wiper and windscreen washer (7,5A).
- F33 - Diagnostic socket (5A).
- F34 - OPTION.
- F35 - Electronic hydraulic pump control unit (7,5A).
- F36 - OPTION.
- F37 - Hydraulic pump control unit and transmission computer power supply (5A).
- F38 - Not used.
- F39 - Not used.
- F40 - Not used.

MAXIFUSE F41 TO F46

- F41 - Free.
- F42 - Electronic box MP2 (40A).
- F43 - Ignition switch (50A).
- F44 - Electronic box MP1 (40A).
- F45 - OPTION Air conditioning relays K3 and K12 (30A).
- F46 - Free.

10 - FUSES AND RELAYS UNDER THE ENGINE HOOD

- Open engine hood 1 in order to gain access to the fuses and relays.
- Replace a used fuse with a new fuse of the same quality and capacity.
- Never reuse a repaired fuse.

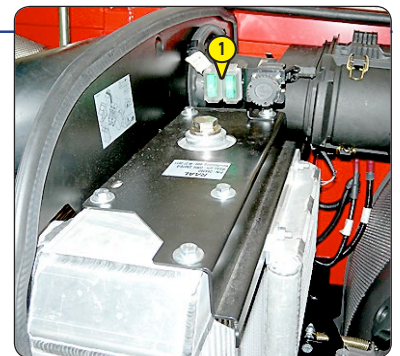

RELAYS

- K20 - Not used.
- K21 - Engine start control relay.
- K22 - Not used.
- K23 - Not used.
- K24 - Not used.
- K25 - Not used.
- K26 - Not used.

MAXIFUSE

- F52 - Engine start-up (30A).
- F53 - Engine ECM computer (30A).

MINIFUSE

- F51 - Diagnostic socket (10A).

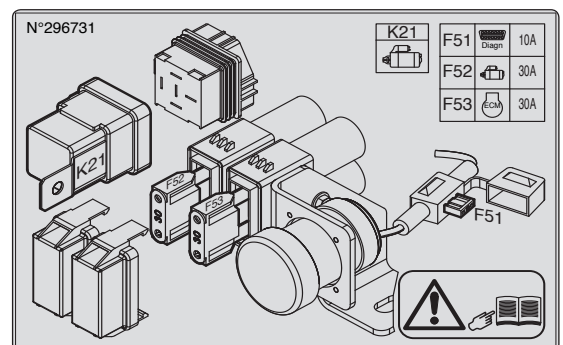



11 - DOOR PRESENCE SENSORS

See: 2 - DESCRIPTION: 6 - MAN-MACHINE INTERFACE (MMI).

12 - CIGARETTE LIGHTER

- Move the emergency brake, release and push the lever forward (position B)..

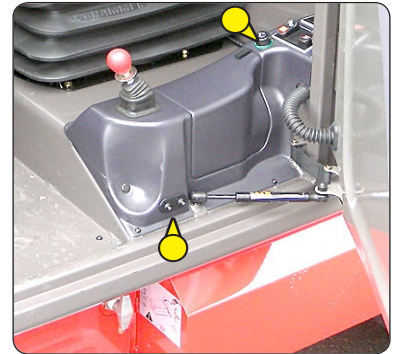

13 - LEVIER DE FREIN DE SECOURS

Pour éviter le desserrage accidentel, le levier est équipé d'un blocage de sécurité. Le levier de frein de secours est utilisé en cas de dysfonctionnement du frein de stationnement au niveau de l'IHM ou d'arrêt longue durée.

- Pour serrer le frein de secours tirer le levier vers l'arrière (position A).
- Pour desserrer le frein de secours débloquer et pousser le levier vers l'avant (position B).

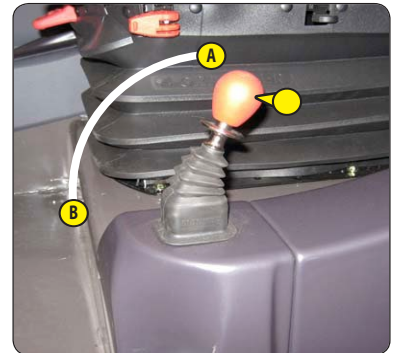

14 - LIGHTING, HORN AND INDICATOR LIGHTS

The switch controls the visual and sound alarms.

- A - All lights are off, the direction indicator lights do not flash.
- B - The right hand direction indicator lights flash.
- C - The left hand direction indicator lights flash.
- D - The sidelights and the rear lights are on.
- E - The dipped headlights and the rear lights are on.
- F - The main beam headlights and the rear lights are on.
- G - Headlight signal.

Pressing the switch sounds the horn.

NOTE: Positions D - E - F - G can be used without the ignition being on.

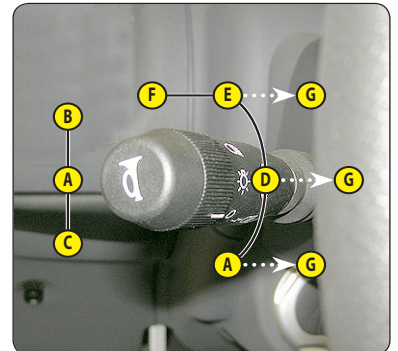

15 - FRONT AND REAR WINDSCREEN WIPER SWITCH

FRONT WINDSCREEN WIPER

- A - Front windscreen wiper stop.
- B - Slow speed for front windscreen wiper.
- C - Fast speed for front windscreen wiper.
- D - Front windscreen wiper intermittent control.
- E - Front windscreen washer, pulse-driven.

REAR WINDSCREEN WIPER

- F - Rear windscreen wiper stop.
- G - Rear windscreen wiper.
- H - Rear windscreen washer, pulse-driven.

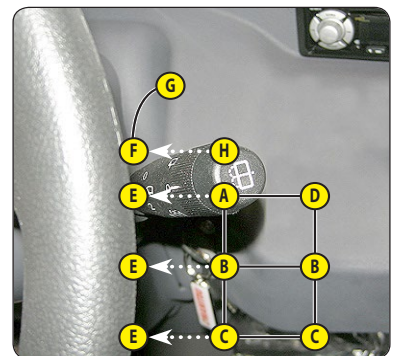

16 - FUNCTION FILES

These files contain the description of the hydraulic controls and the load charts for the attachments used on the telehandler.



17 - HYDRAULIC CONTROLS

According to equipment

Authorization for using the hydraulic controls is given by the validation of the driver's presence (see: 2 - DESCRIPTION: 6 - MAN-MACHINE INTERFACE (MMI)) and if the conditions for using the hydraulic control are followed.

⚠ IMPORTANT ⚠

Do not attempt to alter the hydraulic system pressure. In the event of suspected malfunction, contact your dealer. ANY ALTERATION MAY RENDER THE WARRANTY NULL AND VOID.

Use the hydraulic controls carefully without jerking, to avoid accidents caused by shaking the telehandler.

- A - Lifting and tilting control lever.
- B - Telescoping control button.
- C - Attachment control button.



LIFTING THE LOAD

- The lever A backwards when lifting.
- The lever A forwards when lowering.

TILT OF CARRIAGE

- The lever A to the left for reverse tilt.
- The lever A to the right for forward tilt.
- Button B forwards for extending.
- Button B backwards for retracting.

ATTACHMENT

- The button C forwards or backwards.
- Button C forwards, button C1 limits from 0% to 100% the hydraulic flow of the attachment line.
- Button C backwards, button C2 limits from 0% to 100% the hydraulic flow of the attachment line.

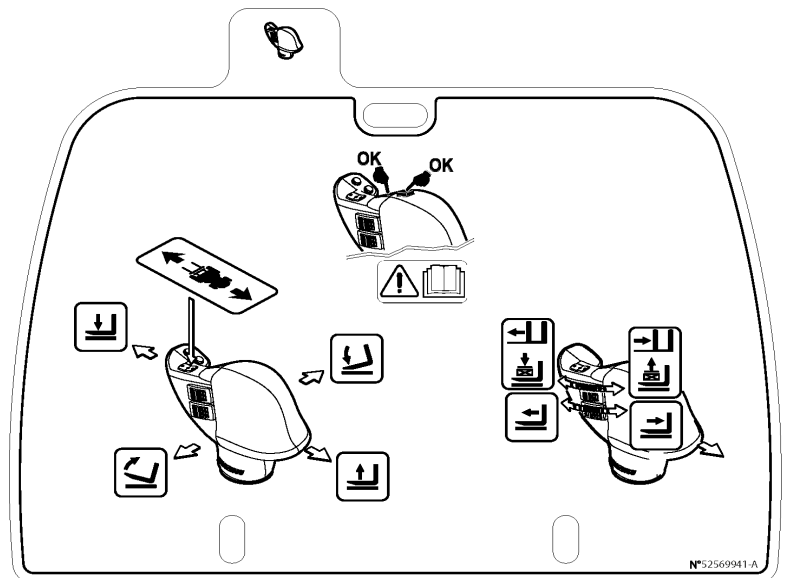

18 - ACCELERATOR PEDAL

19 - SERVICE BRAKE PEDAL

The pedal acts on the front and rear wheels by a power assisted hydraulic brake system, and allows the telehandler to be slowed down and stopped.

18a - INCHING PEDAL

The pedal acts on the front and rear wheels through a system of assisted hydraulic braking that allows to move the truck in a low speed, allowing the precise movements of the charges.



20 - FORWARD/NEUTRAL/REVERSE GEAR SELECTION

Authorisation to use the gear selector is given by validation of driver presence (see: 2 - DESCRIPTION: 6 - MAN-MACHINE-INTERFACE MMI).

When operating this control, the telehandler should be travelling at slow speed and not accelerating.

- FORWARD GEAR: Push the switch forward (position A), indicator light A1 will flash then remain steady the moment you press on the accelerator pedal.
- REVERSE: Push the switch backward (position B), indicator light B1 will flash then remain steady the moment you press on the accelerator pedal. Reversing lights and an acoustic reversing alarm indicate that the telehandler is running in reverse.
- NEUTRAL: Set the switch to the centre position (position C), indicator light C1 will come on and the handbrake is applied (by default).

NOTE: An indicator light that flashes while the telehandler is in use indicates a fault (see: 2 - DESCRIPTION: 6D - SCREEN DISPLAY: MENU SCREEN).

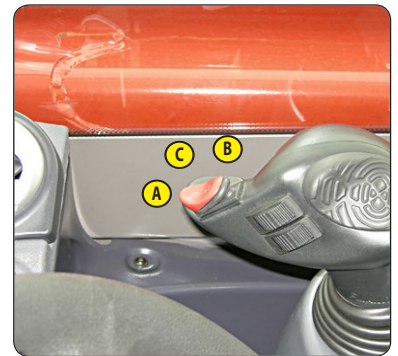

21 - CVT TRANSMISSION AND DRIVING MODE

The machine is equipped with a CVT transmission (continuously variable transmission) that ensures the following:

- **ease of use:** speed can be managed between 0 and 40 km/h without changing gear, simply by operating on the accelerator pedal, always maintaining the best available torque to the wheels,
- **very high pulling force** for all heavy-duty loading operations,
- **maximum comfort** due to the transmission that allows maximum sensitivity and accuracy, also taking advantage of a significant engine brake.

Furthermore, some **driving modes** can be set to adapt the machine to specific needs.

DRIVING MODE

Speed limiter: allows the maximum travel speed to be adjusted.

When required, the maximum torque and hydraulic flow performance to move the telescopic boom are available without increasing the set travel speed.

Conditions and setting:

- move the forward/neutral/reverse gear selection (F/N/R) to the neutral position (N),
- with the I.C. engine on, actuate potentiometer "C" that allows adjusting the maximum travel speed from 0% to 100%, checking the desired speed on the display;
- press the accelerator pedal to move the machine.





Handling and road travel mode: the operator can select the operating mode that meets his needs..

- **The handling mode** allows having the maximum progression and torque performance for all heavy duty handling and loading operations.
- **The road travel mode**, which is much more dynamic and fast, is ideal for all other uses, where speed is important.

In both modes, the maximum travel speed is 40 km/h.

Select the operating mode:





- press the key briefly , LED on, to enable the handling mode;
- press the key briefly , LED off, to enable the road travel mode;
- press the accelerator pedal to move the machine.

SET mode

A further setting is available to simplify specific repeated actions: the SET function.

This function stores the desired travel speed and engine speed to use, for example, a silage unloading bucket, a spreader, a plough, etc...



Conditions and setting:

- forward/neutral/reverse gear selection (F/N/R) to the neutral position (N),
- I.C. engine on,
- briefly press the key  to display the "stored function settings" (the display lasts for 4 seconds):
 - maximum travel speed,
 - desired engine speed;
- the operator can select whether to confirm or end the stored functions;
- in order to confirm the stored functions, press the key  on the "Button panel and keyboard" to enable the SET mode (the LEDs of the keys  +  turn on, the engine speed stabilises to the stored value, the maximum allowed speed for the accelerator control is the stored speed);





- On the contrary, to edit the stored functions:

- adjust the maximum speed by means of the speed potentiometer "C",
- increase the engine speed to the desired value and keep pressed the key  until the alarm sounds and the screen with the selected settings is displayed,

- briefly press the key  on the "Button panel and keyboard" to enable the SET mode (the LEDs of the keys  +  turn on, the engine speed stabilises to the stored value, the maximum allowed speed for the accelerator control is the stored speed).

ECO mode: this function adjusts the transmission so that the set travel speed is maintained, but with a lower engine speed, saving fuel. When the desired speed is reached (with the accelerator pedal) and maintained for a certain time, the ECO functions turns on.

To activate the ECO mode, press the key  and confirm the selection by pressing  the "Button panel and keyboard" key.

22 - I.C. ENGINE SPEED REGULATOR

⚠ IMPORTANT ⚠

The I.C. engine speed regulator can never be used while travelling on the road.

The I.C. engine speed regulator controls the I.C. engine speed and the hydraulic flow of the attachment circuit. The maximum speed of the I.C. engine speed regulator allows achieving the full hydraulic flow in the attachment circuit.



23 - STEERING SELECTION

A - GREEN WHEEL ALIGNMENT LIGHTS



⚠ IMPORTANT ⚠

Before selecting one of the three possible steering positions, bring all 4 wheels into alignment with regards to the telehandler axle.

Never change the steering mode whilst driving.

These lights come on to indicate the alignment of the wheels in relation to the telehandler. The A1 light for the front wheels and the A2 light for the rear wheels.

B - STEERING SELECTION LEVER

- B1 - Front drive wheels (highway traffic). 
- B2 - Front and rear drive wheels in opposite direction (short steering lock). 
- B3 - Front and rear drive wheels in the same direction (crab steering). 

CONTROL FOR ALIGNMENT OF THE WHEELS

⚠ IMPORTANT ⚠

Before driving on roads, it is necessary to check the alignment of the rear wheels and to drive in front wheel steer. The control of the alignment of the rear wheels must be regularly done with the help of the green lights, while driving the telehandler.

In case of anomalies, consult your dealer.

- Shift the steering selection lever B into position B2 (short steering lock).
- Turn the steering wheel and bring the rear wheels into alignment until the A2 light lights up.
- Shift the steering selection lever B into position B1 (highway traffic).
- Turn the steering wheel and bring the front wheels into alignment until the A1 light lights up.





24 - HEATER CONTROL

A - FAN CONTROL

This 3-speed control allows the air to be ventilated through the air vents.

B - TEMPERATURE CONTROL

Allows the temperature inside the cab to be adjusted.

- B1 - The fan pumps in the air at ambient temperature.
- B2 - The fan pumps in warm air.

The intermediate positions allow the temperature to be adjusted.

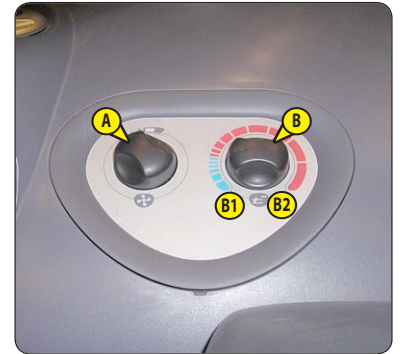

25 - AIR CONDITIONING CONTROLS (AIR CONDITIONING OPTION)

⚠ IMPORTANT ⚠

The air conditioning only works if the telehandler has been started up.

When using your air conditioning unit you must work with the cab closed off.

In winter: So as to ensure correct operation and complete efficiency of the air conditioning unit, start up the compressor once a week, if only for a short spell, so as to lubricate the internal seals.

In cold weather: Warm the I.C. engine before switching on the compressor, so as to allow the coolant that has collected in a liquid state at the lowest point of the compressor circuit to turn into gas under the effect of the heat given off by the I.C. engine, as the compressor is liable to be damaged by coolant in a liquid state.

If your air conditioning does not seem to be working correctly, have it examined by your dealer (see 3 - MAINTENANCE: F - EVERY 2000 HOURS OF SERVICE).

Never try to repair any faults yourself.

A - FAN CONTROL

This 3-speed control allows the air to be ventilated through the air vents.

B - TEMPERATURE CONTROL

Allows the temperature inside the cab to be adjusted.

- B1 - The fan pumps in cold air.
- B2 - The fan pumps in warm air.

The intermediate positions allow the temperature to be adjusted.

C - AIR CONDITIONING CONTROL

This control with a pilot light allows the air conditioning unit to be switched on.

HEATING MODE

- The controls must be adjusted in the following way:
 - C - Control with pilot light off.
 - B - At the required temperature.
 - A - At the desired speed: 1, 2 or 3.

CONDITIONED AIR MODE

- The controls must be adjusted in the following way:
 - C - Control with pilot light on.
 - B - At the required temperature.
 - A - At the desired speed: 1, 2 or 3.

DEMISTING MODE

- The controls must be adjusted in the following way:
 - C - Control with pilot light on.
 - B - At the required temperature.
 - A - At speed 2 or 3.
- For optimum effectiveness, close the heating ventilators.

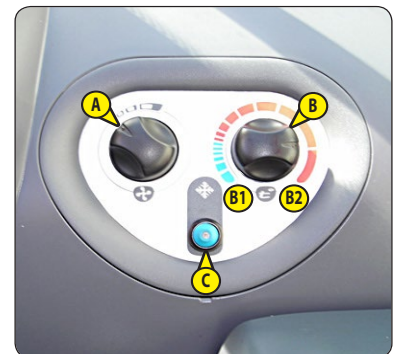

26 - HEATING VENTS

These swivelling heating vents, which can be shut off, allow you to direct and adjust the flow rate inside the cab.

27 - DEMIST VENTS

These vents allow the front windscreen and side windows to be demisted. For optimum efficiency, shut off the heating vents.

28 - LEVEL INDICATOR

Enables the operator to check that the telehandler is in the horizontal position.



29 - DOOR OPEN LEVER

30 - DOOR CLOSE HANDLE

31 - WINDOW REGULATOR SWITCH

32 - SIDE STORAGE SPACE

33 - CEILING LIGHT

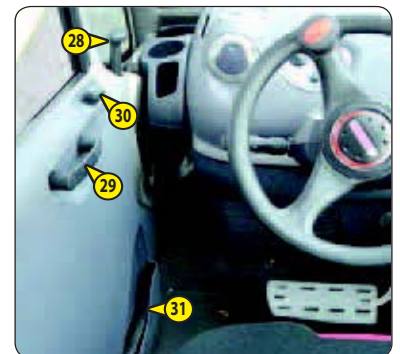

34 - HANDLE FOR REAR WINDOW OPENING

EMERGENCY EXIT

- Use the rear window as an emergency exit, if it is impossible to leave the cab by the door.



35 - HANDLE FOR REAR WINDOW CLOSING



36 - STEERING WHEEL ADJUSTMENT LEVER

This handle enables the angle and height of the steering wheel to be adjusted.

- Pull the knob backwards.
- Adjust the steering wheel to the desired position.
- Push the knob back to lock the steering wheel in position.



37 - DOCUMENT HOLDER NET

Make sure that the operator's manual is in the right place, i.e. in the document holder net.

NOTE: An OPTION waterproof document-holder exists.

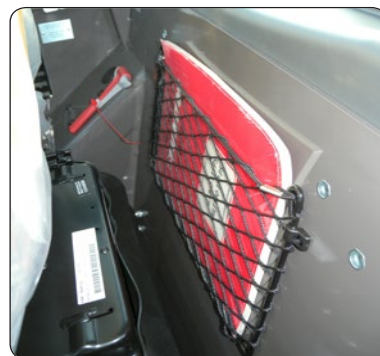

38 - STORAGE COMPARTMENT

39 - ARMREST ADJUSTMENT

The armrest adjustment positions the controller.

⚠ IMPORTANT ⚠

Make sure that the armrest's position is as ergonomic as possible to improve comfortable operation or handling hydraulics.

- Adjust the height of the armrest with handle A
- Adjust the armrest upwards or downwards using thumbscrews B

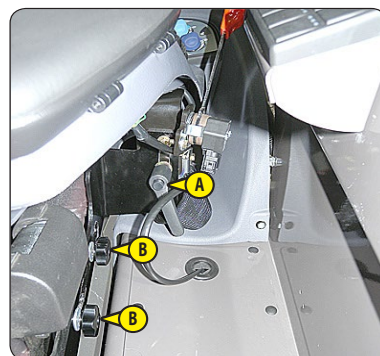

40 - FRONT HEADLIGHTS

- A - Left front indicator.
- B - Left front dipped headlight.
- C - Left front main beam.
- D - Left front sidelight.
- E - Right front indicator.
- F - Right front dipped headlight.
- G - Right front main beam.
- H - Right front sidelight.



41 - REAR LIGHTS

- A - Left rear indicator.
- B - Left rear stoplight.
- C - Rear left headlight.
- D - Rear fog light
- E - Rear reverse light.
- F - Right rear headlight.
- G - Right rear stoplight.
- H - Right rear indicator.

⚠ IMPORTANT ⚠

When driving on the road, widen the rear lights by means of the thumbscrews.

- I - Handling position.
- J - Road driving position.

NOTE: A light protection kit is available as an OPTION.

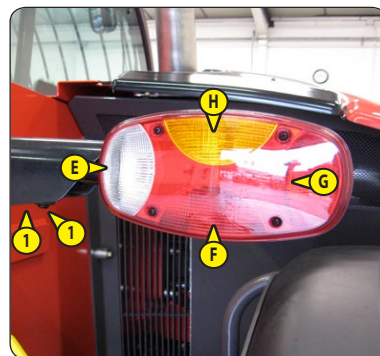
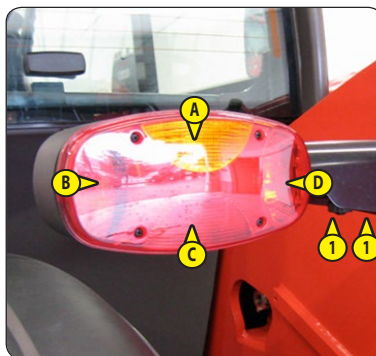



42 - ROTATING BEACON LIGHT

The magnetic rotating beacon light must be clearly visible on the roof of the cab and plugged-in to socket 1.



43 - INSIDE REAR-VIEW MIRROR (OPTION)



44 - BOOM SAFETY WEDGE

⚠ IMPORTANT ⚠

Only use the wedge supplied with the telehandler.

The telehandler is equipped with a boom safety wedge that must be installed on the rod of the lifting cylinder when working beneath the boom (see: 1 - OPERATING AND SAFETY INSTRUCTIONS).



45 - NUMBER PLATE LIGHTING

46 - NUMBER PLATE



47 - EMERGENCY EXIT

EMERGENCY HAMMER

Use the emergency hammer to break one of the windows in the event that it is impossible to exit the cab by the door or by opening the rear window.



48 - RÉSERVOIR DE CARBURANT

Maintenir autant que possible le réservoir à combustible plein, pour réduire au maximum la condensation due aux conditions atmosphériques.

⚠ IMPORTANT ⚠

*Ne jamais fumer ou s'approcher avec une flamme pendant le remplissage ou lorsque le réservoir est ouvert.
Ne jamais effectuer le plein avec le moteur en marche.*

- Si besoin rajouter du gazole (☞ 3 - MAINTENANCE: LUBRIFIANTS ET CARBURANT).
- Enlever le bouchon 1.
- Remplir le réservoir avec du gazole propre et filtré par l'orifice de remplissage.
- Remettre le bouchon.
- Contrôler par un examen visuel l'absence de fuite sur le réservoir et la tuyauterie.

NOTA: Il existe en OPTION un bouchon de réservoir à clé.



49 - RÉSERVOIR DE "DEF" (liquide d'échappement diesel)

⚠ IMPORTANT ⚠

Le liquide d'échappement diesel est un produit corrosif, protéger la carrosserie et porter les équipements de protection individuels (gants et lunettes).

Le niveau de liquide d'échappement diesel est important, un fonctionnement avec un réservoir présentant un niveau faible ou vide peut avoir des conséquences sur les performances du moteur thermique.

- Si besoin rajouter du liquide d'échappement diesel (☞ 3 - MAINTENANCE: LUBRIFIANTS ET CARBURANT).
- Enlever le bouchon 1.
- Remplir lentement le réservoir jusqu'au bas de la goulotte de remplissage.
- Toujours maintenir un bon niveau afin de limiter l'altération du produit.
- Remettre le bouchon.

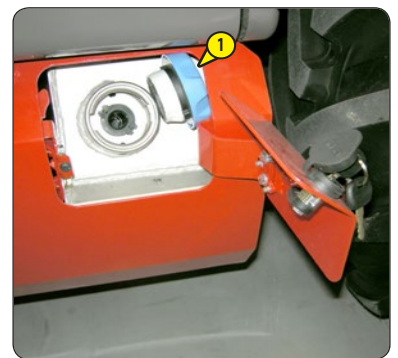

QUALITÉ DU "DEF" (liquide d'échappement diesel)

La qualité du liquide d'échappement diesel peut être mesurée à l'aide d'un réfractomètre, le liquide d'échappement diesel doit être conforme à la norme ISO 22241-1 avec la solution d'urée de 32,5 %.

Réfractomètre MANITOU Référence 959709

CONSERVATION DU "DEF" (liquide d'échappement diesel)

Jusqu'à 4 mois de non utilisation du chariot élévateur, contrôler la qualité du liquide d'échappement diesel à l'aide du réfractomètre.

Au-delà de 4 mois, procéder au remplacement du liquide d'échappement diesel. Vidanger et rincer le réservoir de DEF.

NOTA: Pour un arrêt prolongé du chariot élévateur, ☞ 1 - INSTRUCTIONS ET CONSIGNES DE SÉCURITÉ: ARRÊT DE LONGUE DURÉE DU CHARIOT ÉLÉVATEUR.

TOWING PIN AND HOOK

⚠ IMPORTANT ⚠

Do not tow a trailer or an attachment that is not in perfect working order.

Using a trailer that is not in good condition may affect the steering and braking of the telehandler and therefore the safety of the whole unit.

If a third party helps in coupling or uncoupling the trailer, this person must remain permanently visible to the driver and wait until the telehandler has stopped, the handbrake is on and the I.C engine is switched off before performing the operation.

Located at the rear of the telehandler, this device is used to attach a trailer. Its capacity is limited for each telehandler by the authorized gross vehicle weight, tractive effort and maximum vertical force on the coupling point. This information is given on the manufacturer's plate fixed to each telehandler (see: 2 - DESCRIPTION: IDENTIFICATION OF THE TELEHANDLER).

- To use a trailer, see current regulations in your country (maximum running speed, braking, maximum weight of trailer, etc.).
- Verify the trailer's condition before using it (tyre condition and pressures, electrical connection, hydraulic hose, brake system...).

1 - COUPLING FITTING

⚠ IMPORTANT ⚠

Be careful not to get your fingers caught or crushed during this operation.

Do not forget to put pin back in place.

When uncoupling, make sure that the trailer is supported independently.

COUPLING AND UNCOUPLING THE TRAILER

- To couple the trailer, position the telehandler as close as possible to the trailer ring.
- Put the handbrake on and switch off the I.C. engine.
- Remove the clip 1, lift the trailer pin 2 and place or remove the trailer ring.

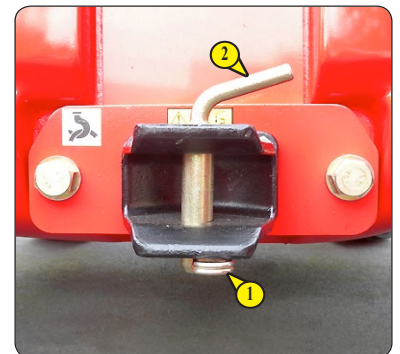

2 - REAR-VIEW MIRROR



3 - REAR ELECTRIC SOCKET

- Connect the male plug to the female socket 1 on the telehandler and make sure the lights of the trailer or the light bar are working properly.
 - A - Left rear indicator.
 - B - OPTION Rear fog lights.
 - C - Ground.
 - D - Right rear indicator.
 - E - Right rear headlight.
 - F - Rear stoplight.
 - G - Rear left headlight + number plate.

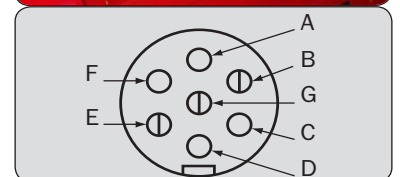
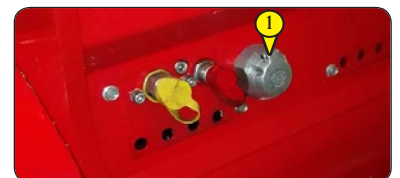



4 - TRAILER BRAKE SYSTEM

- Connect the brake hose to the provided brake unit 1 on the telehandler.
- Make sure the trailer brakes are working properly and test the effects of braking before taking the trailer onto the public highway.

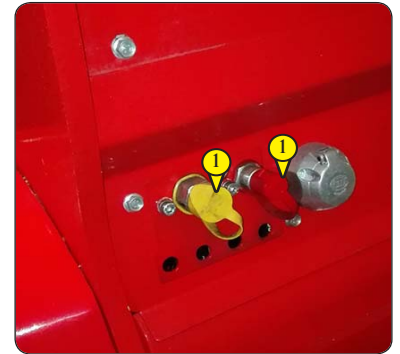

5 - CHASSIS-MOUNTED FRONT TRAILER HOOK

⚠ IMPORTANT ⚠

*Be careful not to get your fingers caught or crushed during this operation.
Do not forget to put pin back in place.
When uncoupling, make sure that the trailer is supported independently.*

COUPLING AND UNCOUPLING THE TRAILER

- To couple the trailer, position the telehandler as close as possible to the trailer ring.
- Put the handbrake on and switch off the I.C. engine.
- Remove the clip 1, lift the trailer pin 2 and place or remove the trailer ring.

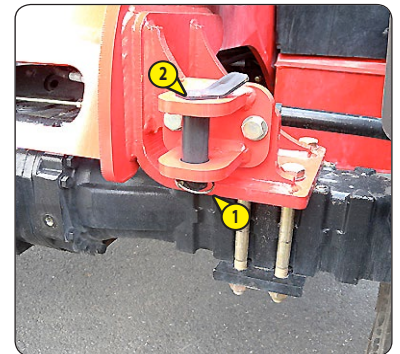

6 - COUPLING LADDER (OPTIONAL)

⚠ IMPORTANT ⚠

*Be careful not to get your fingers caught or crushed during this operation.
Do not forget to put pin back in place.
When uncoupling, make sure that the trailer is supported independently.*

COUPLING AND UNCOUPLING THE TRAILER

- To couple the trailer, position the telehandler as close as possible to the trailer ring.
- Put the handbrake on and switch off the I.C. engine.

ON THE FIXED PIN

- Remove pin 1, remove rod 2 and raise latch 3.
- Insert or remove the trailer ring, lower latch 3 and refit rod 2.

⚠ IMPORTANT ⚠

Do not forget to put clip 1 back in place.

ON THE COUPLING LADDER

- Set the coupling fitting 4 according to the height of the trailer ring.

⚠ IMPORTANT ⚠

Do not forget to put rods and clip back in place.

- Remove the clip 5, lift the trailer pin 6 and place or remove the trailer ring.

⚠ IMPORTANT ⚠

Do not forget to put clip 5 back in place.

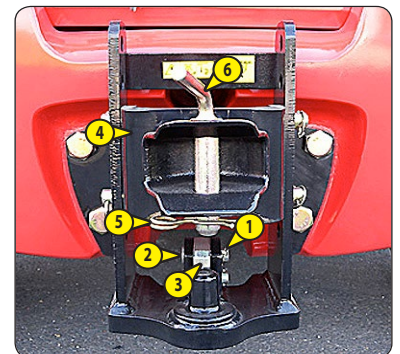

7 - HYDRAULIC TRAILER HOOK (OPTIONAL)

⚠ IMPORTANT ⚠

*Never use the trailer hook to raise the rear of the telehandler
(when changing the rear wheel for example).*

⚠ IMPORTANT ⚠

When uncoupling, make sure that the trailer is supported independently.

- Raise the hydraulic trailer hook to release the hook lock 1 by pressing the upper part of switch 2.
- Pull the knob 3, retain this position and press the lower part of switch 2 to lower the trailer hook.
- Release knob 3.
- Couple or uncouple the trailer.
- Raise the trailer hook by pressing the upper part of switch 2 and then lower the hook to verify that the lock pin is in proper contact with hook 1 lock.

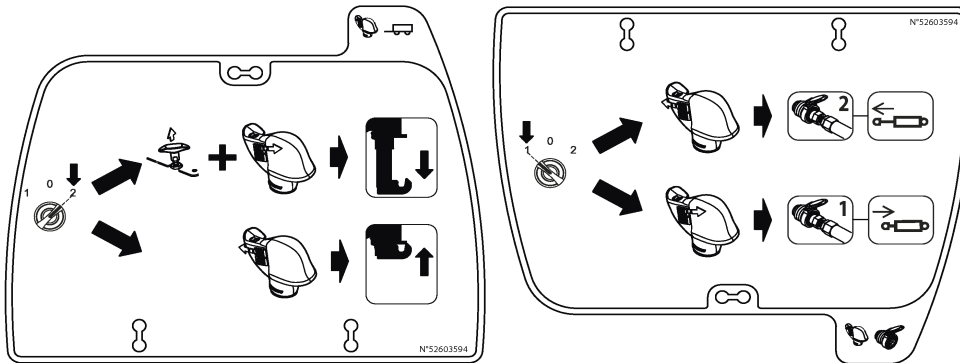
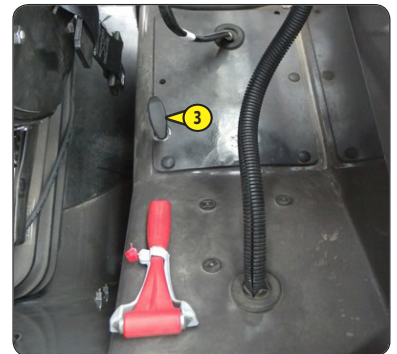
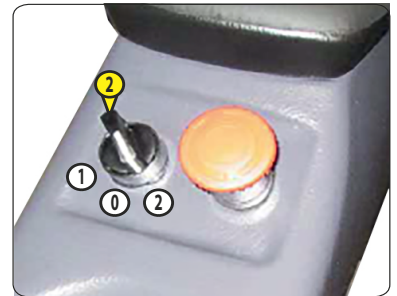
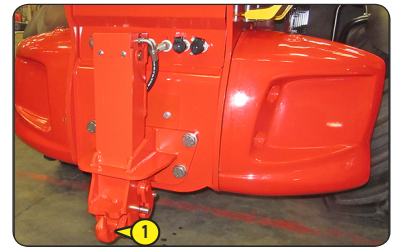

8 - AUTOMATIC TRAILER HOOK (OPTIONAL)

⚠ IMPORTANT ⚠

When uncoupling, make sure that the trailer is supported independently.

COUPLING THE TRAILER

- Remove the automatic towing pin using lever 1.
- Move the telehandler backwards so that the trailer ring slots into the automatic hook.

NOTE: The pin closes automatically when the trailer ring touches the end of the fitting.

The pin can be lowered by hand using lever 1.

UNCOUPLING THE TRAILER

- Remove the pin using lever 1 to uncouple the trailer.





DESCRIPTION AND USE OF THE OPTIONS

- 1 - REVERSE SOUND ALARM
- 2 - "XÉNON" FRONT WORKING HEADLIGHTS
- 3 - BOOM ELECTRICAL PREDISPOSITION
- 4 - STEERING SELECTION ASSISTANT
- 5 - I.C. ENGINE SPEED REGULATOR
- 6 - EXTERIOR DRAIN-BACK
- 7 - ATTACHMENT EASY HYDRAULIC CONNECTION
- 8 - BOOM SUSPENSION
- 9 - ATTACHMENT HYDRAULIC LOCKING
- 10 - BOOM HEAD TELESCOPE
- 11 - BOOM HEAD TELESCOPE + LOCKING HYDRAULIC ATTACHMENT
- 12 - SINGLE OR DOUBLE-ACTING OR DOUBLE-ACTING + DOUBLE-ACTING REAR HYDRAULIC CONTROL PROVISION
- 13 - HYDRAULIC TRAILER HOOK + SINGLE OR DUAL EFFECT REAR HYDRAULIC CONTROL PREDISPOSITION
- 14 - ANGULAR SECTOR ON BOOM

1 - REVERSE SOUND ALARM

2 - "XÉNON" FRONT WORKING HEADLIGHTS

This option cannot be used when driving on the road due to glare.

3 - BOOM ELECTRICAL PREDISPOSITION

Enables an electrical function to be used at the head of the boom.

OPERATION

- Set switch 1 to position A to enable the predisposition, the indicator lights up to show that it is enabled.





4 - STEERING SELECTION ASSISTANT

⚠ IMPORTANT ⚠

*Before driving on roads, it is necessary to check the alignment of the rear wheels and to drive in front wheel steer.
The alignment of the rear wheels must be regularly checked using the green lights while driving the telehandler.
It is not possible to change the steering mode above 11 km/h
In case of anomalies, consult your dealer.*

A - GREEN WHEEL ALIGNMENT LIGHTS

These lights come on to indicate the alignment of the wheels in relation to the telehandler. The A1 light for the front wheels and the A2 light for the rear wheels.

B - DIRECTION SELECTION CONTROL

- B1 - Front drive wheels (highway traffic).
- B2 - Front and rear drive wheels in opposite direction (short steering lock).
- B3 - Front and rear drive wheels in the same direction (crab steering).
- B4 - Front drive wheels and locking of the rear wheel steering angle.

CHANGING THE STEERING MODE

- Press on one of the steering modes B1, B2, B3 or B4.
- Align the rear and front wheels.
 - A continual central light indicates active steering mode.
 - A continual green light + a flashing orange light indicate active steering mode and the requested steering mode.
 - A continual green light + 3 red lights indicate that it is no longer possible to change the steering mode (speed greater than 11 km/h).
 - The 4 lit red lights indicate a fault; operate the wheel to correctly align the wheels.

CHANGING THE STEERING MODE			
MODE	0 km/h	From 1km/h to 11km/h	Over 11km/h
B1	YES	NO	NO
B2	YES	YES	NO
B3	YES	YES	NO
B4	YES	YES	NO

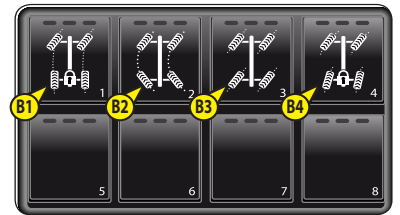

5 - EXTERIOR DRAIN-BACK

Enables connection of an attachment for which drain-back is required.

- A - Fixed position, drain-back not connected.
- B - Movable position, drain-back connected.







6 - ATTACHMENT EASY HYDRAULIC CONNECTION

For easily connecting and disconnecting the hydraulic attachment.

OPERATION

- Switch on telehandler ignition.
- Press on the button for two seconds to release the attachment circuit hydraulic pressure.   screens will be alternately displayed.
- Connect or disconnect the rapid connectors of the hydraulic attachment (see: 4 - OPTIONAL ATTACHMENTS FOR USE WITH THE RANGE: PICKING UP THE ATTACHMENTS).

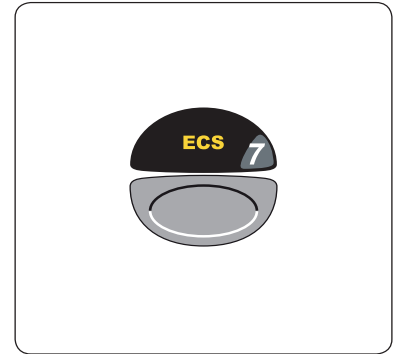

7 - BOOM SUSPENSION

⚠ IMPORTANT ⚠

Boom suspension is enabled up to a lifting height of 3m00 from the carriage pivot pin in relation to the ground with the boom retracted.

When you operate beyond this height or perform another hydraulic movement (tilting, lowering), boom suspension is momentarily deactivated and the  pictogram flashes.

- When the I.C. engine is off, boom suspension is automatically deactivated

The boom is suspended to reduce shaking of the telehandler on rough ground (e.g. moving straw in a field).

OPERATION

- Set the forks or attachment on the ground and relieve the front wheels a few centimetres only.
- A short press on the button activates the boom suspension.
- The  pictogram is continually displayed to confirm its activation.
- A second short press deactivates the boom suspension.



8 - ATTACHMENT HYDRAULIC LOCKING

Enables the attachment to be locked onto the carriage and a hydraulic attachment to be used by the same hydraulic circuit.

⚠ IMPORTANT ⚠

Once the attachment is locked, return valve 1 to position A to prevent accidental release of the attachment.

ATTACHMENT LINE CONTROL

- Set valve 1 to position A.
- Push button 2 forward or backward.

ATTACHMENT LOCKING CONTROL

- Set valve 1 to position B.
- Push button 2 forward to lock the attachment and backward to release it.

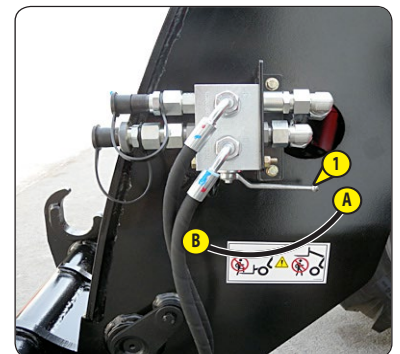

9 - BOOM HEAD TELESCOPE

Enables use of two hydraulic functions on the attachment circuit.

ATTACHMENT LINE L1 CONTROL

- Push button 1 forward or backward.

ATTACHMENT LINE L2 CONTROL

- Turn the A interruptor in A2 and push button 1 forwards or backwards.

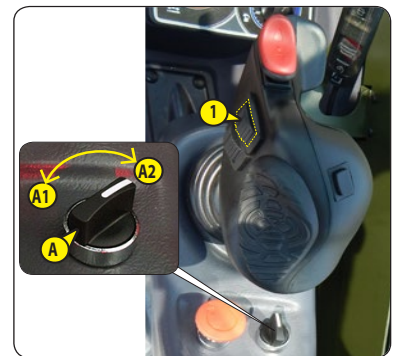
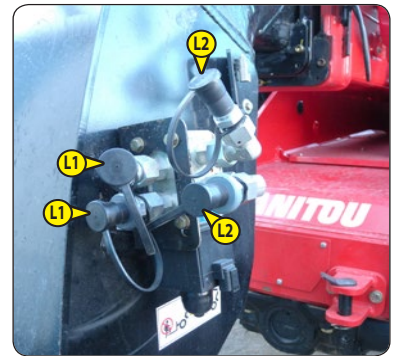

10 - BOOM HEAD TELESCOPE + LOCKING HYDRAULIC ATTACHMENT

⚠ IMPORTANT ⚠

Once the attachment is locked, return valve 1 to position A to prevent accidental release of the attachment.

The addition of these two options on the attachment line allows two hydraulic functions to be used and locks the attachment onto the carriage.

ATTACHMENT LINE L1 CONTROL

- Set valve 1 to position A.
- Push button 2 forward or backward.

ATTACHMENT LINE L2 CONTROL

- Set valve 1 to position A.
- Hold down button 3 and push button 2 forwards or backwards.

ATTACHMENT LOCKING CONTROL

- Set valve 1 to position B.
- Turn the A interruptor in A2 and push button 2 forward to lock the attachment and backward to release it.

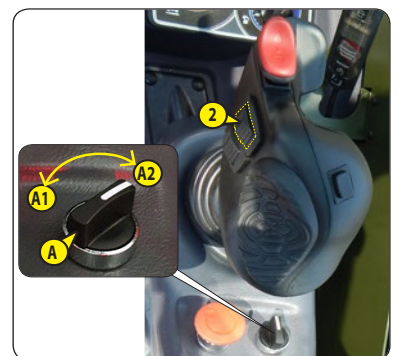
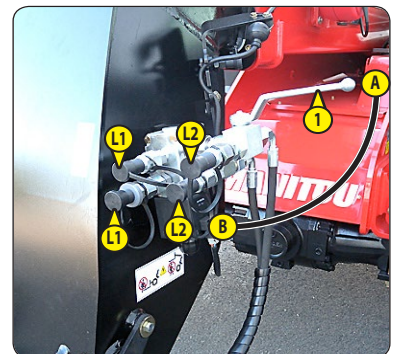

11 - SINGLE OR DOUBLE-ACTING OR DOUBLE-ACTING + DOUBLE-ACTING REAR HYDRAULIC CONTROL PROVISION

Enables the use of a hydraulic attachment at the rear of the telehandler (e.g. a trailer with hydraulic tipping).

SINGLE-ACTING L1 REAR HYDRAULIC CONTROL.

- Press the switch 1 (light on) to power the hydraulic control.
- Push button 2 forward or backward.

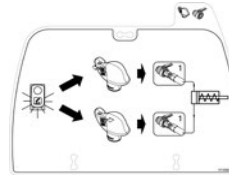

DOUBLE-ACTING L1 / L2 REAR HYDRAULIC CONTROL

- Press the switch 1 (light on) to power the hydraulic control.
- Turn the A interruptor in A2 and push button 2 forwards or backwards.

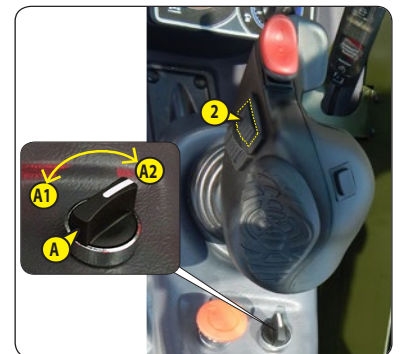
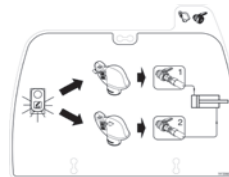

DOUBLE-ACTING L1 / L2 AND DOUBLE-ACTING L3 / L4 REAR HYDRAULIC CONTROL

DUAL EFFECT ATTACHMENT L1 / L2

- Press the switch 1 (light on) to power the hydraulic control.
- Push button 2 forward or backward.

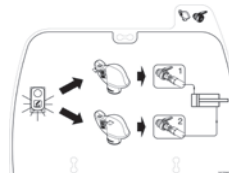

DUAL EFFECT ATTACHMENT L3 / L4

- Press the switch 1 (light on) to power the hydraulic control.
- Hold down button 3 and push button 2 forwards or backwards.

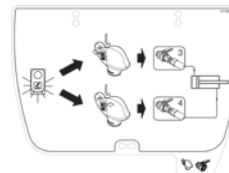



**12 - HYDRAULIC TRAILER HOOK + SINGLE OR DUAL EFFECT REAR HYDRAULIC CONTROL
PREDISPOSITION**

Enables the use of the trailer eye (see: 2 - DESCRIPTION: TRAILER PIN AND HOOK) or a hydraulic attachment at the rear of the telehandler.

HYDRAULIC TRAILER HOOK + SINGLE EFFECT REAR HYDRAULIC CONTROL L3

HYDRAULIC TRAILER HOOK

- Press the switch 1 (light on) to power the hydraulic control.
- Push the button 2 forwards or backwards to use the hydraulic trailer hook (see: 2 - DESCRIPTION: TRAILER PIN AND HOOK: F - HYDRAULIC TRAILER HOOK).

SINGLE EFFECT ATTACHMENT L3

- Press the switch 1 (light on) to power the hydraulic control.
- Turn the A interruptor in A2 and push button 2 forwards or backwards.

HYDRAULIC TRAILER HOOK + DUAL EFFECT REAR HYDRAULIC CONTROL L3 / L4

HYDRAULIC TRAILER HOOK

- Press the switch 1 (light on) to power the hydraulic control.
- Push the button 2 forwards or backwards to use the hydraulic trailer hook (see: 2 - DESCRIPTION: TRAILER PIN AND HOOK: F - HYDRAULIC TRAILER HOOK).

DUAL EFFECT ATTACHMENT L3 / L4

- Press the switch 1 (light on) to power the hydraulic control.
- Turn the A interruptor in A2 and push button 2 forwards or backwards.

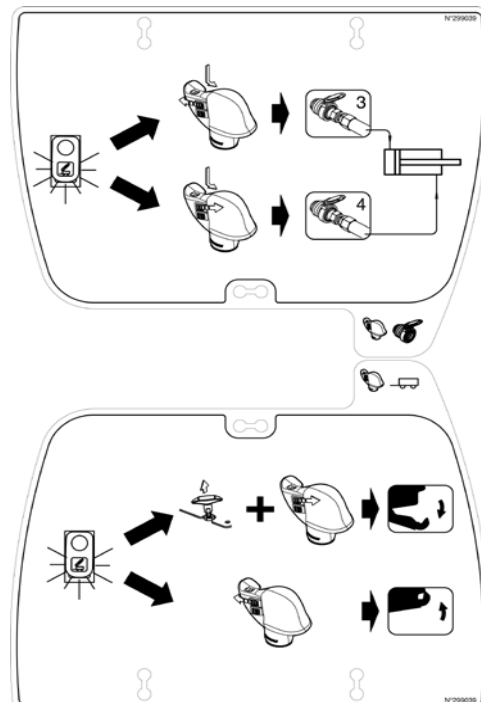
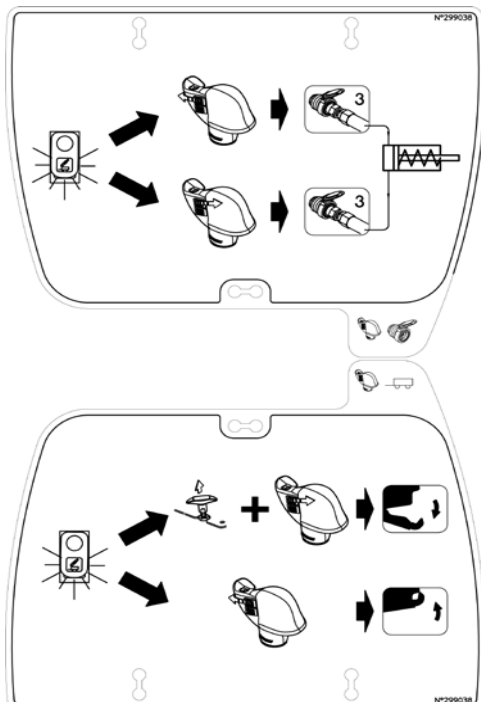
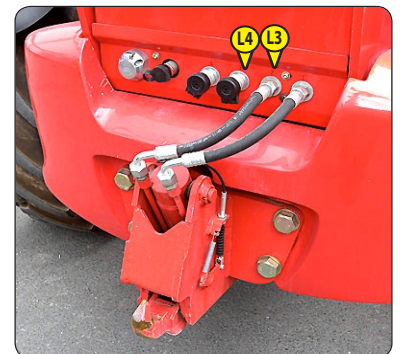
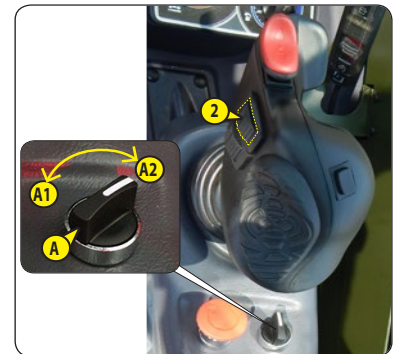



13 - ANGULAR SECTOR ON BOOM

The angular sector displays the boom angle, and thus improves the reading of the load charts.



14 - WINDSCREEN GRILL

DESCRIPTION

The windscreen grill provides additional protection for the operator from any external elements spattered on the windscreen.

This grill must be removable from inside the cab to enable an emergency exit.

EMERGENCY EXIT

- After breaking the windscreen with the emergency hammer, push (with force) on the grill at A to remove it.





3 - MAINTENANCE



3 - MAINTENANCE

<u>ORIGINAL MANITOU SPARE PARTS AND EQUIPMENT</u>	<u>3-3</u>
<u>TELEHANDLER MAINTENANCE</u>	<u>3-4</u>
<u>DAILY AND WEEKLY MAINTENANCE</u>	<u>3-4</u>
<u>MANDATORY FIRST 500 HOURS OR 6 MONTH SERVICE</u>	<u>3-5</u>
<u>ENTRETIEN PÉRIODIQUE</u>	<u>3-</u>
<u>PERIODIC MAINTENANCE</u>	<u>3-6</u>
<u>OCCASIONAL MAINTENANCE AND OPERATION</u>	<u>3-8</u>
<u>FILTERS CARTRIDGES AND BELTS</u>	<u>3-9</u>
<u>LUBRICANTS AND FUEL</u>	<u>3-10</u>
<u>➔ 10 HOUR - DAILY MAINTENANCE OR EVERY 10 HOURS OF SERVICE</u>	<u>3-12</u>
<u>➔ 50 HOUR - DAILY MAINTENANCE OR EVERY 50 HOURS OF SERVICE</u>	<u>3-16</u>
<u>➔ ① 500 HOUR - PERIODIC MAINTENANCE - EVERY 500 HOURS OF SERVICE</u>	<u>3-22</u>
<u>➔ ② 1000 HOUR - PERIODIC MAINTENANCE - EVERY 1000 HOURS OF SERVICE OR 2 YEARS</u>	<u>3-28</u>
<u>➔ ③ 2000 HOUR - PERIODIC MAINTENANCE - EVERY 2000 HOURS OF SERVICE OR 4 YEARS</u>	<u>3-34</u>
<u>➔ ④ 3000 HOUR - PERIODIC MAINTENANCE - EVERY 3000 HOURS OF SERVICE OR 6 YEARS</u>	<u>3-38</u>
<u>➔ ⑤ 4000 HOUR - PERIODIC MAINTENANCE - EVERY 4000 HOURS OF SERVICE OR 8 YEARS</u>	<u>3-39</u>
<u>➔ OCCASIONAL MAINTENANCE</u>	<u>3-40</u>
<u>➔ OCCASIONAL OPERATION</u>	<u>3-46</u>



ORIGINAL MANITOU SPARE PARTS AND EQUIPMENT

OUR TELEHANDLERS MUST BE SERVICED USING ORIGINAL MANITOU PARTS.

BY ALLOWING THE USE OF NON ORIGINAL MANITOU PARTS, YOU RISK:

⚠ IMPORTANT ⚠

THE USE OF COUNTERFEIT PARTS OR COMPONENTS NOT APPROVED BY THE MANUFACTURER, WILL CAUSE YOU TO LOSE THE BENEFIT OF THE CONTRACTUAL GUARANTEE.

- Legally - to be held responsible in the event of an accident.
- Technically - to cause operating malfunctions or shorten the life of the telehandler.

BY USING ORIGINAL MANITOU PARTS FOR MAINTENANCE OPERATIONS, YOU BENEFIT FROM OUR KNOW-HOW

Through its network, MANITOU provides the user with,

- Know-how and competence.
- The guarantee of high-quality work.
- Original replacement parts.
- Help with preventive maintenance.
- Efficient help with diagnosis.
- Improvements due to experience feedback.
- Operator training.
- Only the MANITOU network has detailed knowledge of the design of the telehandler and therefore the best technical ability to provide maintenance.

⚠ IMPORTANT ⚠

ORIGINAL REPLACEMENT PARTS ARE DISTRIBUTED ONLY BY MANITOU AND THE DEALER NETWORK.

The list of dealers is available on the MANITOU website www.manitou.com



TELEHANDLER MAINTENANCE

DAILY AND WEEKLY MAINTENANCE

⚠ IMPORTANT ⚠

THE OPERATOR IS AUTHORISED TO CARRY OUT THIS MAINTENANCE.

These maintenance operations enable the operator to keep the telehandler in a clean, safe condition.

MANDATORY FIRST 500 HOURS OR 6 MONTH SERVICE

⚠ IMPORTANT ⚠

THIS SERVICE MUST BE CARRIED OUT AFTER APPROXIMATELY THE FIRST 500 HOURS OF SERVICE OR WITHIN THE 6 MONTHS FOLLOWING THE START-UP OF THE MACHINE (WHICHEVER OCCURS FIRST).

PERIODIC MAINTENANCE

⚠ IMPORTANT ⚠

THE PERIODIC MAINTENANCE MUST BE CARRIED OUT BY A PROFESSIONAL APPROVED BY THE MANITOU NETWORK

MAINTENANCE SCHEDULE

This schedule enables the operator to remain up-to-date with the periodic maintenance carried out on the telehandler by notifying the total number of hours of operation completed and the date of the service carried out by the MANITOU network approved professional.

OCCASIONAL MAINTENANCE AND OPERATION

These maintenance and other operations are carried out as required to ensure the safety and correct maintenance of the telehandler.

DAILY AND WEEKLY MAINTENANCE

🔄 10 HOUR - DAILY MAINTENANCE OR EVERY 10 HOURS OF SERVICE

- CHECK	Telehandler environment	3-12
- CHECK	Engine oil level	3-12
- CHECK	Cooling liquid level	3-12
- CHECK	Fuel pre-filter	3-13
- GREASE	Boom pads *	3-13
		<i>* Every 10 hours during the first 50 hours, then once at 250 hours.</i>
- CHECK	Warning device and longitudinal stability limiter.....	3-14

🔄 50 HOUR - DAILY MAINTENANCE OR EVERY 50 HOURS OF SERVICE

- CHECK	Gear box oil level	3-16
- CHECK	Tyre pressure	3-16
- CHECK	Wheel nut torque.....	3-16
- CHECK	Waterproofing on front axle differential	3-17
- CHECK	Waterproofing on rear axle differential	3-17
- CHECK	Waterproofing of front wheel reducing gears	3-17
- CHECK	Waterproofing of rear wheel reducing gears	3-17
- CHECK	Brake oil level.....	3-17
- CHECK	Hydraulic fluid level.....	3-18
- CHECK	Windscreen washer liquid level.....	3-18
- CLEAN	Radiator cores	3-19
- CLEAN/CHECK	Condenser core (Air-conditioning OPTION)	3-19
- GREASING	General greasing	3-20



MANDATORY FIRST 500 HOURS OR 6 MONTH SERVICE

FIRST 500 HOURS BEFORE THE FIRST 6 MONTHS

- If the telehandler completes its first 500 hours of service before the first 6 months are up, carry out the mandatory service and the 500 hour periodic maintenance (500 HOUR - PERIODIC MAINTENANCE - EVERY 500 HOURS OF SERVICE)

FIRST 6 MONTHS BEFORE THE FIRST 500 HOURS

- If the telehandler has not completed 500 hours of service in the first 6 months, just carry out the mandatory service.

MANDATORY SERVICE

- CHECK	Gear box oil level	3-16
- CHECK	Tyre pressure	3-16
- CHECK	Wheel nut torque	3-16
- CHECK	Waterproofing on front axle differential	3-17
- CHECK	Waterproofing on rear axle differential	3-17
- CHECK	Waterproofing of front wheel reducing gears	3-17
- CHECK	Waterproofing of rear wheel reducing gears	3-17
- CHECK	Brake oil level	3-17
- CHECK	Hydraulic fluid level	3-18
- CHECK	Windscreen washer liquid level	3-18
- CLEAN	Radiator cores	3-19
- CLEAN/CHECK	Condenser core (Air-conditioning OPTION)	3-19
- GREASING	General greasing	3-20
- CHECK	Fork wear *	3-26
- CHECK	Engine silent blocks *	3-33
- CHECK	Gearbox silent blocks *	3-33
- CHECK	Gearbox controls *	3-33
- CHECK	Brake system pressure *	3-33
- CHECK	Jib pads wear *	3-33
- CHECK	Condition of wiring harness and cables *	3-33
- CHECK	Lights and signals *	3-33
- CHECK	Alarms *	3-33
- CHECK	Condition of the rear view mirrors *	3-33
- CHECK	Structure of the cab *	3-33
- CHECK	Structure of the chassis *	3-33
- CHECK	Attachment carriage *	3-33
- CHECK	Condition of attachments *	3-33

** Consult your dealer.*



PERIODIC MAINTENANCE

MAINTENANCE SCHEDULE

WHEN DUE ➡	OR		500 H	1000 H OR 2 YEARS	1500 H OR 3 YEARS	2000 H OR 4 YEARS
	FIRST 6 MONTHS	FIRST 500 HOURS				
PERIODIC MAINTENANCE ➡	MANDATORY SERVICE	MANDATORY SERVICE + 1	1	1+2	1	1+2+3
MACHINE COUNTER ➡						
DATE OF SERVICING ➡						

WHEN DUE ➡	2500 H OR 5 YEARS	3000 H OR 6 YEARS	3500 H OR 7 YEARS	4000 H OR 8 YEARS	4500 H OR 9 YEARS	5000 H OR 10 YEARS	5500 H OR 11 YEARS
PERIODIC MAINTENANCE ➡	1	1+2+4	1	1+2+3 +5	1	1+2	1
MACHINE COUNTER ➡							
DATE OF SERVICING ➡							

WHEN DUE ➡	6000 H OR 12 YEARS	6500 H OR 13 YEARS	7000 H OR 14 YEARS	7500 H OR 15 YEARS	8000 H OR 16 YEARS	8500 H OR 17 YEARS	9000 H OR 18 YEARS
PERIODIC MAINTENANCE ➡	1+2+4	1	1+2	1	1+2+3 +5	1	1+2
MACHINE COUNTER ➡							
DATE OF SERVICING ➡							

➡ 1 500 HOUR - PERIODIC MAINTENANCE - EVERY 500 HOURS OF SERVICE

- CHECK	Hydraulic oil	3-22
- REPLACE	Engine oil	3-22
- REPLACE	Engine oil filter	3-22
- CHECK	Automatic alternator belt tensioner	3-23
- REPLACE	Transmission oil filter (hydrostatic pump)	3-24
- REPLACE	Front axle differential oil	3-24
- REPLACE	Rear axle differential oil	3-24
- REPLACE	Hydraulic return oil filter cartridge	3-25
- REPLACE	Cab ventilation filters	3-25
- REPLACE	Fuel pre-filter	3-26
- REPLACE	Fuel filter	3-26
- CHECK	Fork wear *	3-26

** Consult your dealer.*



➔ ② 1000 HOUR - PERIODIC MAINTENANCE - EVERY 1000 HOURS OF SERVICE OR 2 YEARS

IN ADDITION, CARRY OUT PERIODIC MAINTENANCE FOR 500 HOURS OF SERVICE.

- CLEAN	Fuel tank	3-29
- REPLACE	Cooling liquid	3-30
- REPLACE	Dry air filter cartridge	3-31
- REPLACE	Engine crankcase ventilation filter	3-31
- REPLACE	Front wheel reducer oil	3-31
- REPLACE	Rear wheel reducer oil	3-31
- REPLACE	Gear box oil	3-32
- CLEAN	Speed sensor	3-32
- CHECK	Engine silent blocks *	3-33
- CHECK	Gearbox silent blocks *	3-33
- CHECK	Gearbox controls *	3-33
- CHECK	Brake system pressure *	3-33
- CHECK	Jib pads wear *	3-33
- CHECK	Condition of wiring harness and cables *	3-33
- CHECK	Lights and signals *	3-33
- CHECK	Alarms *	3-33
- CHECK	Condition of the rear view mirrors *	3-33
- CHECK	Structure of the cab *	3-33
- CHECK	Structure of the chassis *	3-33
- CHECK	Attachment carriage *	3-33
- CHECK	Condition of attachments *	3-33
- REPLACE	Brake oil *	3-33
- BLEED	Brake circuit *	3-33
- ADJUST	Brake *	3-33

** Consult your dealer.*

➔ ③ 2000 HOUR - PERIODIC MAINTENANCE - EVERY 2000 HOURS OF SERVICE OR 4 YEARS

IN ADDITION, CARRY OUT PERIODIC MAINTENANCE FOR 500 HOURS OF SERVICE AND 1000 HOURS OF SERVICE.

- CHECK	Wheel nut tightening torques	3-34
- REPLACE	Hydraulic oil	3-34
- CLEAN	Inlet strainer for hydraulic fluid reservoir	3-34
- REPLACE	Breather for the hydraulic oil tank	3-34
- CHECK	Radiator *	3-36
- CHECK	Transmission pressure *	3-36
- CHECK	Steering *	3-36
- CHECK	Steering swivel joints *	3-36
- CHECK	Wear of the brake pads and the brake disk *	3-36
- CHECK	Condition of boom assembly *	3-36
- CHECK	Bearings and articulation rings *	3-36
- CHECK	Condition of hoses and flexible pipes *	3-36
- CHECK	Condition of cylinders (leakage, rods) *	3-36
- CHECK	Hydraulic circuit pressures *	3-36
- CHECK	Bearings and articulation rings *	3-36
- CLEAN/CHECK	Air-conditioning (OPTIONAL) *	3-36
- REPLACE	Compressor belt (air conditioning OPTION) *	3-36

** Consult your dealer*

➔ ④ 3000 HOUR - PERIODIC MAINTENANCE - EVERY 3000 HOURS OF SERVICE OR 6 YEARS

- REPLACE	Safety dry air filter cartridge	3-38
-----------	---------------------------------------	------

➔ ⑤ 4000 HOUR - PERIODIC MAINTENANCE - EVERY 4000 HOURS OF SERVICE OR 8 YEARS

- REPLACE	DEF (Diesel Exhaust Fluid) feed pump filter	3-39
-----------	---	------

➔ OCCASIONAL MAINTENANCE

- REPLACE	Wheels	3-40
- ADJUST	Front headlights	3-40



OCCASIONAL MAINTENANCE AND OPERATION

- RESETTING	Longitudinal stability limiter and warning device	3-41
- REPLACE	Alternator belt	3-42
- CLEAN	DEF (Diesel Exhaust Fluid) tank	3-43

** Consult your dealer*

↻ OCCASIONAL OPERATION

- TOWING OR WINCHING	Telehandler	3-46
- SLINGING	Telehandler	3-47
- TRANSPORTING	Telehandler	3-48



FILTERS CARTRIDGES AND BELTS

➔ 1 500 HOUR - PERIODIC MAINTENANCE - EVERY 500 HOURS OF SERVICE

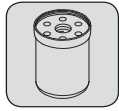

ENGINE OIL FILTER
Part number: 796241

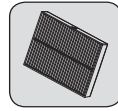

CAB INTERNAL VENTILATION FILTER
Part number: 933871

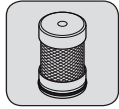

HYDROSTATIC PUMP OIL FILTER
Part number: 737524

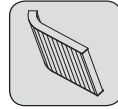

CAB EXTERNAL VENTILATION FILTER
Part number: 261971



HYDRAULIC RETURN OIL FILTER CARTRIDGE
Part number: 282526

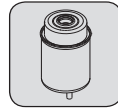

FUEL FILTER
Part number: 52523728

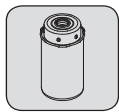

FUEL PRE-FILTER
Part number: 52523727

➔ 2 1000 HOUR - PERIODIC MAINTENANCE - EVERY 1000 HOURS OF SERVICE OR 2 YEARS

ADD FILTER ELEMENTS OF PERIODIC MAINTENANCE OF 500 HOURS OF SERVICE.

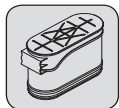

DRY AIR FILTER CARTRIDGE
Part number: 299936

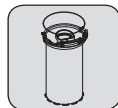

ENGINE CRANKCASE VENTILATION FILTER
Part number: 796022

➔ 3 2000 HOUR - PERIODIC MAINTENANCE - EVERY 2000 HOURS OF SERVICE OR 4 YEARS

ADD FILTER ELEMENTS OF PERIODIC MAINTENANCE OF 500 HOURS AND 1000 HOURS OF SERVICE.

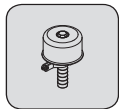

BREATHER FOR THE HYDRAULIC OIL TANK
Part number: 278288

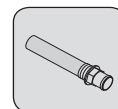

SUCTION STRAINER FOR HYDRAULIC OIL TANK
Part number: 922903

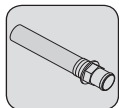

SUCTION STRAINER FOR HYDRAULIC OIL TANK
Part number: 259500

➔ 4 3000 HOUR - PERIODIC MAINTENANCE - EVERY 3000 HOURS OF SERVICE OR 6 YEARS

ADD FILTER ELEMENTS OF PERIODIC MAINTENANCE OF 500 HOURS AND 1000 HOURS OF SERVICE.



SAFETY DRY AIR FILTER CARTRIDGE
Part number: 299937

➔ 5 4000 HOUR - PERIODIC MAINTENANCE - EVERY 4000 HOURS OF SERVICE OR 8 YEARS

ADD FILTER ELEMENTS OF PERIODIC MAINTENANCE OF 500 HOURS AND 1000 HOURS OF SERVICE.



DEF (Diesel Exhaust Fluid) FEED PUMP FILTER
Part number: 941976

➔ ENTRETIEN OCCASIONNEL

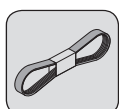

COMPRESSOR BELT
(AIR CONDITIONING OPTION)
Part number: 796760

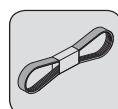

ALTERNATOR BELT
Part number: 798258



LUBRICANTS AND FUEL

⚠ IMPORTANT ⚠

USE THE RECOMMENDED LUBRICANTS AND FUEL:

- For topping up, oils may not be miscible.
- For oil changes, MANITOU oils are perfectly appropriate.

DIAGNOSTIC ANALYSIS OF OILS

If a service or maintenance contract has been organized with the dealer, a diagnostic analysis of engine, transmission and axle oils may be requested depending on the rate of use.

(*) REQUIRED FUEL SPECIFICATION

Use a high-quality fuel to obtain optimal performance of the engine.

- EN590 diesel fuel (sulphur content < 10 ppm)
- ASTM D975 diesel fuel (sulphur content < 15 ppm)

(**) DEF (Diesel Exhaust Fluid) SPECIFICATION

- Aqueous urea solution at 32.5 % (ISO22241)
- Solidification at -11 °C and 10 % expansion
- Non-flammable product
- Thermal degradation (>60 °C)
- Storage between -5 °C and 30 °C

⚠ IMPORTANT ⚠

Corrosive to metals, requires wearing personal protection (gloves and goggles).

RECOMMENDED LUBRICANT

ENGINE		RECOMMENDED LUBRICANT									
PARTS TO BE LUBRICATED	CAPACITY										
ENGINE	13 L (3.4 US gal)	SAE 0W40									
		SAE 5W30									
		SAE 10W30									
		MANITOU EVOLOGY 10W40 API CJ4									
		SAE 15W40									
		-40°C	30	-20-	10	0+	10	+20+	30	+40+	50°C
COOLING CIRCUIT	23 L (6 US gal)	COOLANT -35°C									
		-40°C	30	-20-	10	0+	10	+20+	30	+40+	50°C
FUEL TANK	135 L (35.6 US gal)	FUEL*									
DEF (Diesel Exhaust Fluid) TANK	8,7 L (2.2 US gal)	DEF**									
TRANSMISSION		RECOMMENDED LUBRICANT									
PARTS TO BE LUBRICATED	CAPACITY										
GEARBOX	2,95 L (0.76 US gal)	MANITOU OIL DEXRON III AUTOMATIC TRANSMISSION									
		-40°C	30	-20-	10	0+	10	+20+	30	+40+	50°C
CARDAN JOINT		MANITOU GREASE BLUE MULTI-PURPOSE									
TELESCOPIC BOOM		RECOMMENDED LUBRICANT									
PARTS TO BE LUBRICATED	CAPACITY										
TELESCOPIC BOOM SHOES		MANITOU GREASE BLACK MULTI-PURPOSE									
		-40°C	30	-20-	10	0+	10	+20+	30	+40+	50°C
GENERAL GREASING OF TELESCOPIC BOOM		MANITOU GREASE BLUE MULTI-PURPOSE									
BRAKES		RECOMMENDED LUBRICANT									
PARTS TO BE LUBRICATED	CAPACITY										
BRAKE CIRCUIT	1 L 0,26 U.S. gal	MANITOU OIL MINERAL BRAKE FLUID									



HYDRAULIC											
PARTS TO BE LUBRICATED	CAPACITY	RECOMMENDED LUBRICANT									
		-40°C	30	-20-	10	0+	10	+20+	30	+40+	50°C
HYDRAULIC OIL TANK	153 L (40.4 US gal)	ISO VG 100									
		ISO VG 68									
		MANITOU OIL HYDRAULIC ISO VG 46									
		ISO VG 37									
		ISO VG 32									

CABINE		
PARTS TO BE LUBRICATED	CAPACITY	RECOMMENDED LUBRICANT
WINDSCREEN WASHER TANK		WINDSCREEN WASHER LIQUID

FRONT AXLE											
PARTS TO BE LUBRICATED	CAPACITY	RECOMMENDED LUBRICANT									
		-40°C	30	-20-	10	0+	10	+20+	30	+40+	50°C
FRONT AXLE DIFFERENTIAL	12 L (3.1 US gal)	MANITOU OIL SPECIAL IMMERSED BRAKES									
FRONT WHEEL REDUCING GEAR	2 x 1,9 L (2 x 0.5 US gal)	MANITOU OIL SAE80W90 MECHANICAL TRANSMISSION									
FRONT WHEEL REDUCING GEAR PIVOTS		MANITOU GREASE BLUE MULTI-PURPOSE									

REAR AXLE											
PARTS TO BE LUBRICATED	CAPACITY	RECOMMENDED LUBRICANT									
		-40°C	30	-20-	10	0+	10	+20+	30	+40+	50°C
REAR AXLE DIFFERENTIAL	13,5 L (3.5 US gal)	MANITOU OIL SPECIAL IMMERSED BRAKES									
REAR WHEEL REDUCING GEAR	2 x 1,9 L (2 x 0.5 US gal)	MANITOU OIL SAE80W90 MECHANICAL TRANSMISSION									
REAR WHEEL REDUCING GEAR PIVOTS		MANITOU GREASE BLUE MULTI-PURPOSE									
REAR AXLE OSCILLATION		MANITOU GREASE BLUE MULTI-PURPOSE									

PACKAGING

OIL						
PRODUCT	PACKAGING / PART NO.					
	1 L (0.26 US gal)	2 L (0.52 US gal)	5 L (1.32 US gal)	20 L (5.28 US gal)	55 L (14.5 US gal)	209 L (55.2 US gal)
- MANITOU EVOLGY OIL 10W40 API CJ4			895837	895838	895839	895840
- MANITOU ISO VG 46 HYDRAULIC OIL			545500	582297	546108	546109
- MANITOU DX III G AUTOMATIC TRANSMISSION OIL			947972	947973	947974	947975
- SPECIAL MANITOU OIL FOR IMMERSED BRAKES			545976	582391	947918	894257
- MANITOU SAE80W90 MECHANICAL TRANSMISSION OIL		499237	720184	546330	546221	546220
- MANITOU MINERAL BRAKE FLUID	490408					4500078

GREASE						
PRODUCT	PACKAGING / PART NO.					
	400 ml	400 gr (0.88 lb)	1 kg (2.2 lb)	5 kg (11 lb)	20 kg (44 lb)	50 kg (110.2 lb)
- MANITOU BLACK MULTI-PURPOSE LUBRICANT		947766	161590			499235
- MANITOU BLUE MULTI-PURPOSE LUBRICANT		161589	720683	554974	499233	489670

LIQUID						
PRODUCT	PACKAGING / PART NO.					
	1 L (0.26 US gal)	2 L (0.52 US gal)	5 L (1.32 US gal)	20 L (5.28 US gal)	55 L (14.5 US gal)	209 L (55.2 US gal)
- COOLING LIQUID -35 °C	53017514			53017515		53017600
- WINDSCREEN WASHER LIQUID	490402	486424				
- Diesel Exhaust Fluid (DEF)			958575		958576	

➔ **10 HOUR - DAILY MAINTENANCE OR EVERY 10 HOURS OF SERVICE**

CHECK

Telehandler environment

Carry out a general inspection of the area surrounding the telehandler:

- Any leaks or liquid stains on the ground.
- Additional items on the telehandler and in the cab.
- Fixing and locking of the attachment.
- Fixing and adjustment of rear-view mirrors.
- Condition of the tires, to detect cuts, blisters, wear, etc.

⚠ IMPORTANT ⚠

Follow the operator instructions (➔ 1 - INSTRUCTIONS AND SAFETY PRECAUTIONS: OPERATOR INSTRUCTIONS).

CLEANLINESS OF THE TELEHANDLER

- Cleanliness of lights and rear-view mirror.
- Excessively dirty or build-up of material (e.g. straw, flour, sawdust, organic waste, etc.).
- On a daily basis, and according to the conditions of use, the operator must ensure that the telehandler is in a clean condition.
- Particular attention should be paid to any build-up of flammable materials (e.g. straw, flour, sawdust, organic waste, etc.) and lubricant or fuel leaks, which significantly increase the risk of fire breakouts.
- A regular inspection of the whole telehandler, particularly the engine housing and the central area of the chassis, should be made to establish the cleaning frequency required to prevent potential build-up of material or spillages.

CHECK

Engine oil level

Place the telehandler on level ground with the engine stopped, and let the oil settle in the sump.

- Open the engine bonnet.
- Pull out dipstick 1.
- Clean the dipstick and check the correct level between the two notches.
- If necessary, add oil (➔ LUBRICANTS AND FUEL) through the filler port 2.
- Visually check that there is no leakage or seepage of oil in the engine.

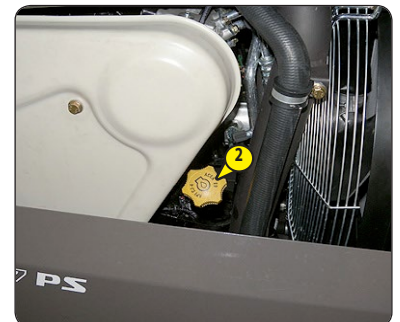

CHECK

Cooling liquid level

Place the telehandler on level ground with the engine stopped, and allow the engine to cool.

⚠ IMPORTANT ⚠

To avoid any risk of spraying or burning, wait until the engine has cooled down before removing the cooling circuit filler plug.

In an emergency, you can use water as a cooling liquid, then change the cooling circuit liquid as soon as possible.

- Open the engine bonnet.
- The liquid must be at the MAXIMUM level on the expansion tank 1.
- If necessary, add cooling liquid (➔ LUBRICANTS AND FUEL) through the filler port 2.
- Visually check that there is no leakage in the radiator and pipes.



CHECK

Fuel pre-filter

⚠ IMPORTANT ⚠

Carefully clean the outside of the pre-filter and its holder, to prevent dust from getting into the system.

- Open the engine bonnet.
- Check for the presence of water in pre-filter tank 1 and drain if necessary.
- Place a receptacle under the drain plug 2 and loosen it in two to three thread turns.
- Allow the diesel fuel to flow out until it is free from impurities and water.
- Tighten the drain plug 2 while the diesel fuel is running out.

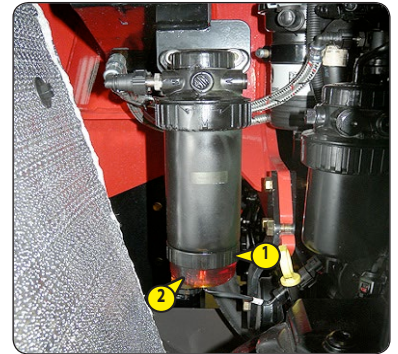

GREASE

Boom pads *

To be carried out every 10 hours during the first 50 hours service, then once at 250 hours.

⚠ IMPORTANT ⚠

If the lift truck is used in an abrasive environment (dust, sand, coal) Use lubricating varnish (MANITOU part no.: 483536). Please consult your dealer. Fully extend the boom.

- Apply the grease with a brush (← LUBRICANTS AND FUEL) to the 4 sides of the telescope(s).
- Telescope the boom several times in order to spread the coat of grease evenly.
- Remove the surplus of grease.



** Every 10 hours during the first 50 hours, then once at 250 hours.*



CHECK

Warning device and longitudinal stability limiter

⚠ IMPORTANT ⚠

Carefully follow the boom positioning instructions.

In case of doubt during the test procedure, exit by briefly pressing the cancel button .

If in doubt, contact your dealer.

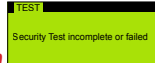









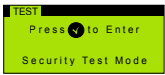

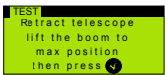
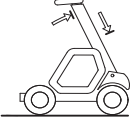

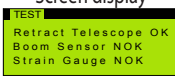
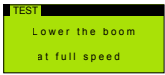
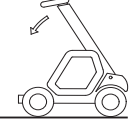
The appearance of the screen indicates that an instruction, a cancellation request or a late response has not been observed.

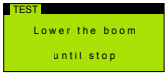
These tests are essential for checking the correct operation and adjustment of the different components of the device.

- Place the telehandler on flat, level ground with the wheels straight.

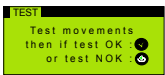
- Hold down the test button .

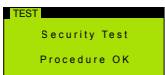
STAGE 1		⇒	Start of procedure.	⇒		⇒	Go to stage 2.
STAGE 2		⇒	 Place the telehandler without any attachment, with the telescopic boom fully retracted and raised.	⇒		⇒	TEST OK ⇒ Go to stage 3.
						⇒	TEST NOT OK Screen display  ⇒ Consult your dealer.
STAGE 3		⇒	 Lower the telescopic boom with the engine running at full revs and the hydraulic control at the maximum setting. Lowering slows until movement is cut-off.	⇒		⇒	TEST OK ⇒ Go to stage 4.
						⇒	TEST NOT OK Screen display  ⇒ Consult your dealer.
STAGE 4		⇒	 Continue to lower the telescopic boom with the engine running at full revs and the hydraulic control at the maximum setting. Lowering slows until movement is next cut-off.	⇒		⇒	TEST OK ⇒ Go to stage 5.
						⇒	TEST NOT OK Screen display  ⇒ Consult your dealer.
STAGE 5		⇒	Request in the following order: a reverse tilt, a carriage forward tilt (dumping), a telescope extension and a boom descent. None of these 4 movements should be possible.	⇒		⇒	TEST OK Confirm ⇒ Go to stage 6.
						⇒	TEST NOT OK Cancel  Exit test mode. ⇒ Consult your dealer.
STAGE 6		⇒	End of procedure.				



Page intentionally left blank

➔ **50 HOUR - DAILY MAINTENANCE OR EVERY 50 HOURS OF SERVICE**

CHECK

Gear box oil level

Park the lift truck on level ground with the boom raised, the engine stopped. Carry out the check within 5 minutes of the engine being stopped.

⚠ IMPORTANT ⚠

Raise the boom and place the boom safety wedge on the rod of the lifting cylinder (⚠ 1 - INSTRUCTIONS AND SAFETY RECOMMENDATIONS: FORKLIFT TRUCK MAINTENANCE INSTRUCTIONS).

- Let the oil level 1 and check the level through the hole 2.
- If necessary fill up with oil (⚠ 3 - MAINTENANCE: LUBRICANTS AND FUEL) through the hole 2.
- The level is correct when the oil level is flush with the edge of the hole 2.
- Visually check that there is no leakage or seepage of oil in the gearbox.

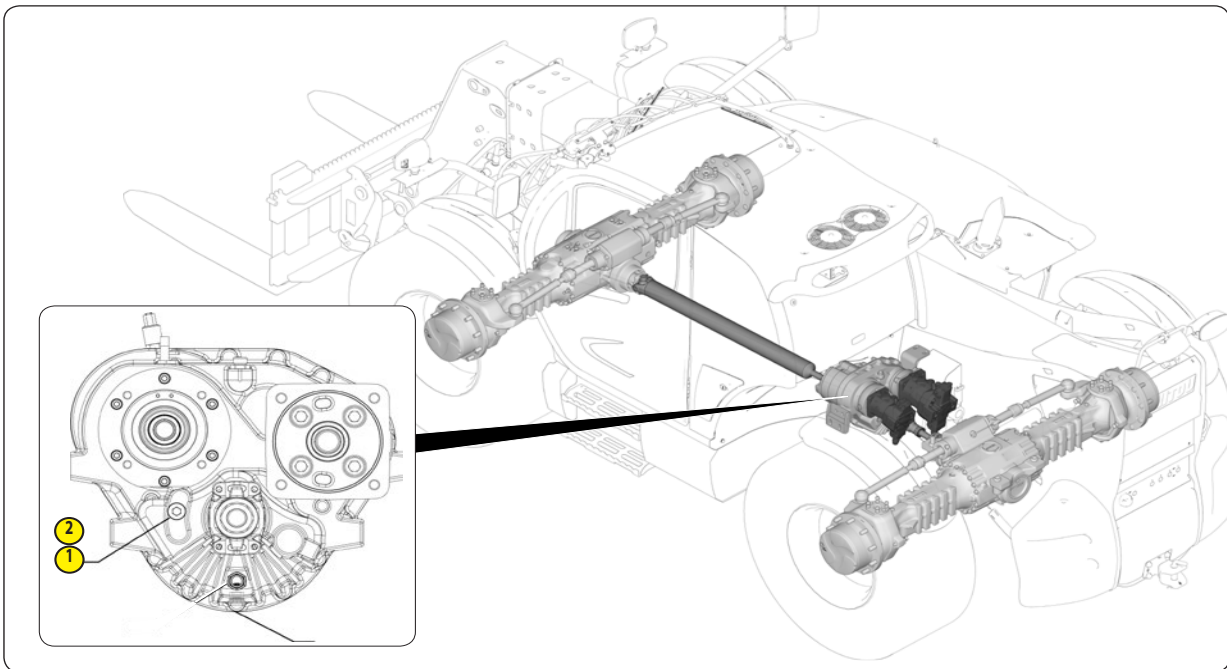

CHECK

Tyre pressure

CHECK

Wheel nut torque

⚠ IMPORTANT ⚠

Check that the air hose is correctly connected to the tyre valve before inflating and keep everyone at a distance during inflation. Adhere to the recommended tyre pressures.

- Check the torque load of the wheel nuts. Non-compliance with this instruction can lead to damage and failure of the wheel bolts and distortion of the wheels.
- Check and restore tyre pressures if necessary (⚠ 2 - DESCRIPTION: TYRES).

NOTE: There is an OPTIONAL wheel toolkit.

CHECK

Waterproofing on front axle differential

CHECK

Waterproofing on rear axle differential

Place the lift truck on level ground with the engine stopped.

- Carry out a visual check of filling, level and drain plugs for any seepage or leaks.
- In the event of leaks or seepage, monitor the level:
 - Remove the level plug 1, the oil should be flush with the edge of the hole.
 - If necessary, add oil (☞ LUBRICANTS AND FUEL) through the filler port 2.
 - Refit and tighten the level plug 1 (tightening torque 34 to 49 Nm)

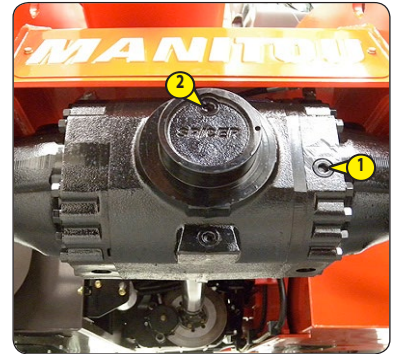

CHECK

Waterproofing of front wheel reducing gears

CHECK

Waterproofing of rear wheel reducing gears

Place the lift truck on level ground with the engine stopped.

- Carry out a visual check of level plugs for any seepage or leaks.
- In the event of leaks or seepage, monitor the level:
 - Place level plug 1 in a horizontal position.
 - Remove the level plug; the oil should be flush with the edge of the opening.
 - If necessary, add oil (☞ LUBRICANTS AND FUEL) using the same opening.
 - Refit and tighten the level plug (tightening torque 34 to 49 N.m).



CHECK

Brake oil level

Place the lift truck on level ground.

⚠ IMPORTANT ⚠

If the brake oil level is abnormal consult your dealer.

- Open the protective casing 1 with the ignition key.
- Check tank 2. The level is correct when it is situated at the MAX level on the tank.
- Visually check that there is no leakage in the tank and pipes.
- If necessary, add oil (☞ LUBRICANTS AND FUEL).
- Remove cap 3.
- Add oil through filler port 4.
- Refit the cap 3.

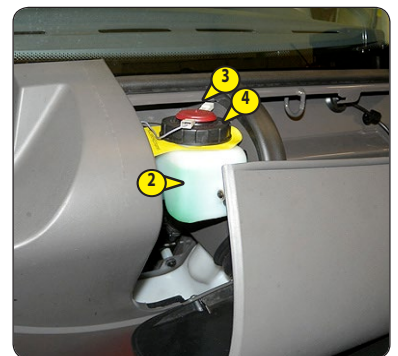

CHECK

Hydraulic fluid level

Place the lift truck on level ground with the engine stopped, and the boom retracted and lowered as far as possible.

⚠ IMPORTANT ⚠

Use a clean funnel and clean the underside of the oil drum before filling.

- Check dipstick 1, the correct level must stand at the level of the red point.
- If necessary, add oil (⚠ LUBRICANTS AND FUEL).
- Visually check that there is no leakage in the tank and pipes.
- Remove the filler cap lock 2.
- Remove cap 3.
- Add oil through filler port 4.
- Refit the cap and its lock.

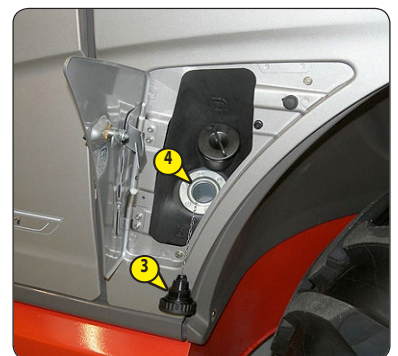
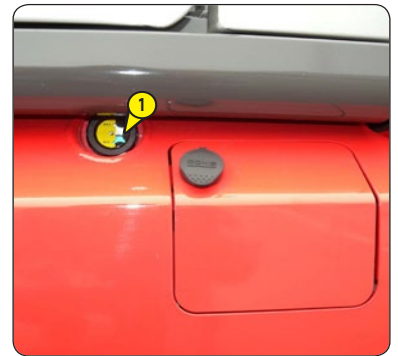

CHECK

Windscreen washer liquid level

- Open the protective casing 1 with the ignition key.
- Visually check the level in tank 2.
- If necessary add windscreen washer liquid (⚠ LUBRICANTS AND FUEL).
- Remove cap 3.
- Add windscreen washer liquid through filler port.
- Refit the cap.

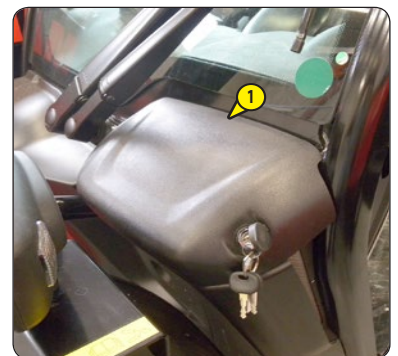

CLEAN

Radiator cores

⚠ IMPORTANT ⚠

In a polluting atmosphere, clean the radiator core every day.

Do not use a water jet or high-pressure steam as this could damage the radiator fins.

- Open the engine bonnet.
- If necessary, clean the suction grid on the engine hood.
- Clean grid 1.
- Using a soft cloth, clean the radiator in order to remove as much dirt as possible.
- Clean the radiator using a compressed air jet aimed in the opposite direction to the cooling air flow.
- Remove impurities via the panel using handle 2.

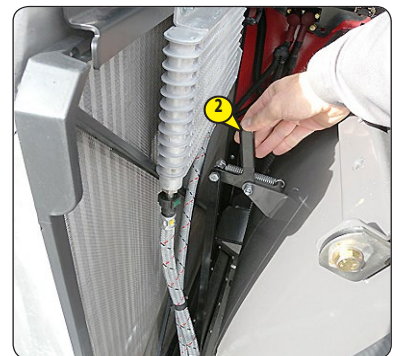
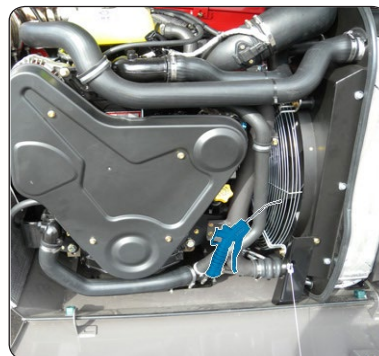
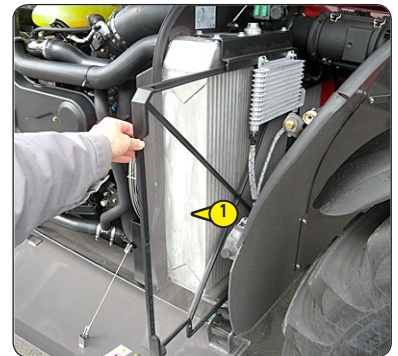

CLEAN/CHECK

Condenser core (Air-conditioning OPTION)

⚠ IMPORTANT ⚠

In a polluting atmosphere, clean the radiator core every day.

Do not use a water jet or high-pressure steam as this could damage the condenser fins.

- Remove the protective grid 1 and clean it if necessary.
- Visually check whether the condenser is clean and clean it if necessary.
- Clean the condenser using a compressed air jet aimed in the same direction as the air flow.
- Clean with the fans running for best results.



GREASING

General greasing

To be carried out weekly, if the telehandler has been operated for less than 50 hours during the week.

⚠ IMPORTANT ⚠

In the event of prolonged use in an extremely dusty or oxidising atmosphere, reduce this interval to 10 working hours or every day.

Clean and lubricate the following points with grease (see: 3 - MAINTENANCE: LUBRICANTS AND FUEL) and remove the surplus of grease.

Each grease nipple is identified by a yellow cap.

TELESCOPIC BOOM

- 1 - Lubricators of the boom axle (1 lubricator).
- 2 - Lubricators of the carriage axle (2 lubricators).
- 3 - Lubricator of the tilt cylinder head axle (1 lubricator).
- 4 - Lubricator of the tilt cylinder foot axle (1 lubricator).
- 5 - Lubricators of the carriage connecting rod axles (3 lubricators).
- 6 - Lubricator of the lifting cylinder foot axle (1 lubricator).
- 7 - Lubricator of the lifting cylinder head axle (1 lubricator).
- 8 - Lubricator of the compensation cylinder foot axle (1 lubricator).
- 9 - Lubricator of the compensation cylinder head axle (1 lubricator).

FRONT AND REAR WHEEL REDUCTION GEAR PIVOTS

- 10 - Lubricators of the wheel reduction gear pivot pins (8 lubricators).

REAR AXLE OSCILLATION

- 11 - Rear axle oscillation lubricators (2 lubricators)
- 12 - Rear axle oscillation lubricators (2 lubricators).

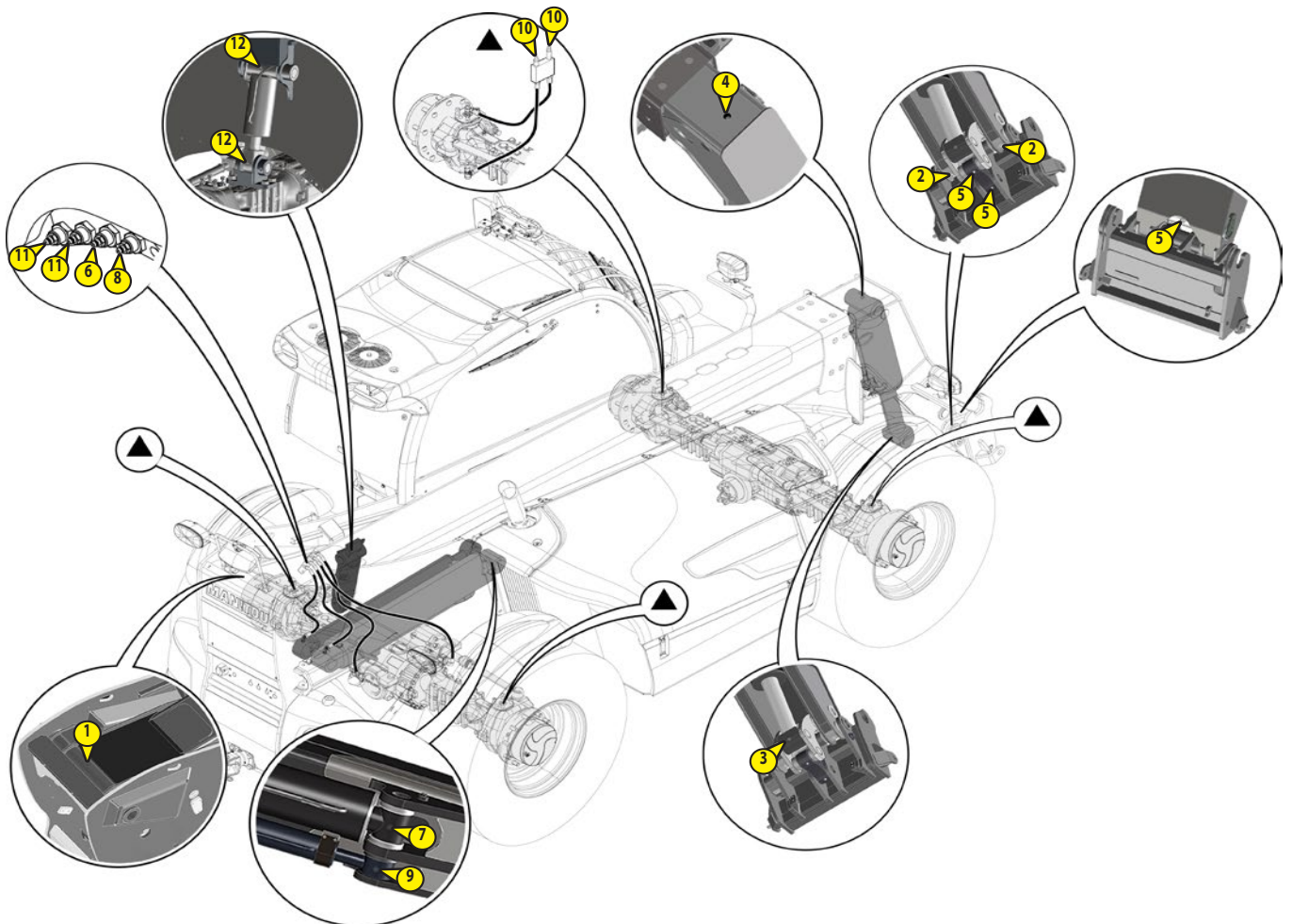



Page intentionally left blank

500 HOUR - PERIODIC MAINTENANCE - EVERY 500 HOURS OF SERVICE

CHECK

Hydraulic oil

MANITOU offers a hydraulic oil analysis kit, which might make it possible to delay the recommended due date for periodic maintenance (2000 hours). In this case we recommend an analysis of the hydraulic oil every 500 hours of operation.

The oil analysis kit also makes it possible to confirm the oil quality so as to obtain a deadline of 2000 hours for specific uses causing constraints on the hydraulic circuit: extreme environmental conditions, use of the attachments with a very high hydraulic flow rate (such as a sweeper, or a concrete mixer).

- You can order an oil analysis kit from your dealer.
- When you receive the kit, collect a sample and follow the kit instructions.
- Keep the analysis report or replace the hydraulic oil, depending on the results.

MANITOU oil analysis kit Part No. 958162.



REPLACE

Engine oil

REPLACE

Engine oil filter

Place the lift truck on level ground, let the engine run at idle for a few minutes, then stop the engine.

⚠ IMPORTANT ⚠

*Dispose of the waste oil in an ecological manner.
Hand-tighten the oil filter and lock in place with a quarter turn.*

DRAINING THE OIL

- Open the engine bonnet.
- Remove access panel 1.
- Place a container under drain plug 2 and unscrew the plug.
- Take drain hose 3.
- Place the end of the drain hose in the container and screw the hose fully to the drain connector 2.
- Remove level and filling plug 4 to ensure that the oil is drained properly.

REPLACEMENT OF THE FILTER

- Unscrew and discard the engine oil filter 5, together with its seal.
- Clean the filter bracket with a clean, lint-free cloth.
- Lightly grease the new seal before refitting the new oil filter (see: 3 - MAINTENANCE: FILTERS CARTRIDGES AND BELTS) on its bracket.

NOTE: Ensure that the notches of the dust seal are correctly fitted in the grooves of the filter holder.

FILLING UP THE OIL

- Remove, clean and refit drain hose 3.
- Replace and tighten the drain plug 2.
- Fill up with oil (see: 3 - MAINTENANCE: LUBRICANTS AND FUEL) through filler port 4.
- Wait a few minutes to allow the oil to flow into the sump.
- Start the engine and let it run for a few minutes.
- Check for possible leaks from the drain plug and the oil filter.
- Stop the engine, wait a few minutes and check the correct level between the two level marks on the dipstick 6.
- Top up the level if necessary.
- Refit access panel 1.

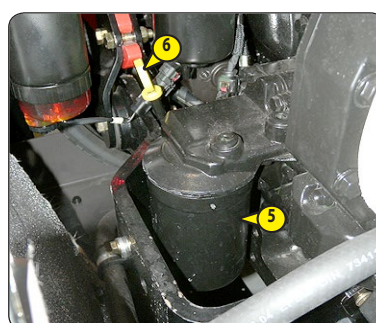
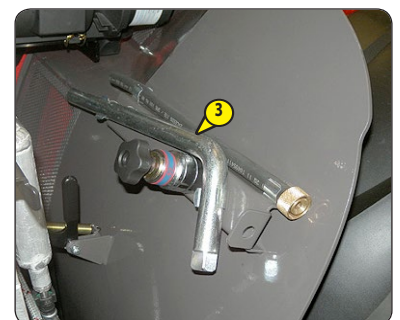

CHECK

Automatic alternator belt tensioner

- Open engine bonnet and the lower cover 1.
- Remove the protective casing 2.

ALTERNATOR BELT TENSION

- The belt tensioner is designed to work within the travel limits of the arm between the two fixed end-stops 3.
- Visually check the travel of the arm. If the pivoting arm stop 4 touches one of the two fixed end-stops 3, check the condition of the alternator bracket, the belt tensioner and the return pulley.
- Check the length of the alternator belt and change if necessary (see: 3 - MAINTENANCE: H - OCCASSIONAL MAINTENANCE).
- Do not check the automatic tensioner spring tension if the alternator belt tension is correct. If in doubt, contact your dealer.

AUTOMATIC TENSIONER SPRING TENSION (IF NECESSARY)

- Place a 1/2 in. socket wrench in the square of the automatic tensioner 5 to slacken the belt and remove it.
- Release the force and remove the socket wrench.
- Make a mark A on the pivoting arm, measure a distance of 21 mm from this point and make another mark B on the fixed part of the tensioner.
- Place a torque wrench, with the centres of the pulley and the tensioner aligned and turn the tensioner until marks A and B are aligned. The torque should be 20 N.m.
- If necessary replace the automatic belt tensioner.
- Refit the alternator belt (see: 3 - MAINTENANCE: H - OCCASSIONAL MAINTENANCE).

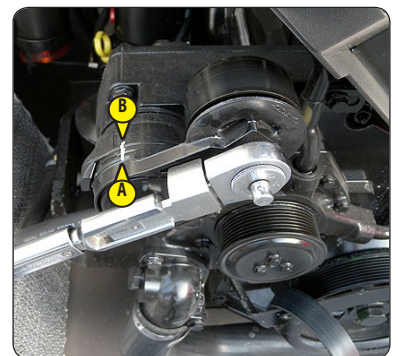
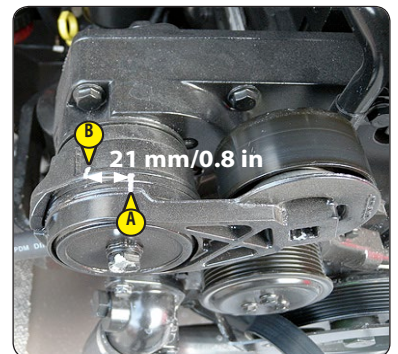
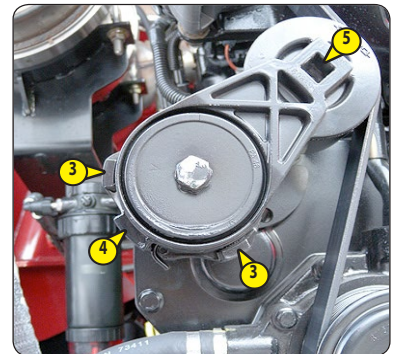
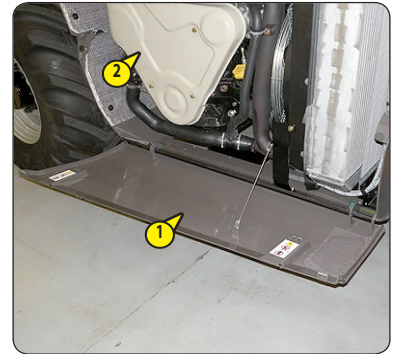

REPLACE

Transmission oil filter (hydrostatic pump)

- À l'aide d'une clé, dévisser le corps du filtre 1 sur la pompe de transmission pour remplacer la cartouche à l'intérieur 2.
- Extraire la cartouche 2.
- Nettoyer le support du filtre et le corps du filtre 1 avec un chiffon propre qui ne pluche pas.
- Remplacer la cartouche 1 par un modèle neuf de mêmes caractéristiques (voir: 3 - MAINTENANCE: TABLEAU DES ÉLÉMENTS FILTRANTS ET COURROIES") et remplir le corps du filtre 1 avec de l'huile hydraulique (voir: 3 - MAINTENANCE: LUBRIFIANTS ET CARBURANT) puis le monter en veillant à bien le mettre en place.
- Démarrer le chariot et contrôler qu'il n'y a pas de fuites.

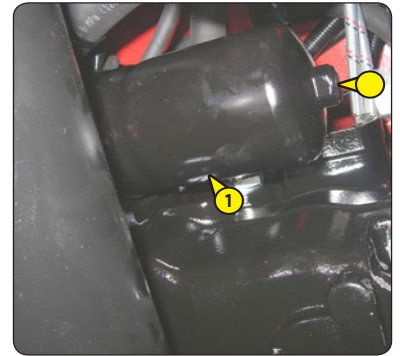

REPLACE

Front axle differential oil

REPLACE

Rear axle differential oil

Place the lift truck on level ground with the engine stopped and the still warm differential oil.

⚠ IMPORTANT ⚠

Dispose of the drain oil in an ecological manner.

- Place a container under the drain plugs 1 and unscrew them.
- Remove level plug 2 and filling plug 3 to ensure that the oil is drained properly.
- Refit and tighten the drain plugs 1 (tightening torque 34 to 49 N.m).
- Fill up with oil (LUBRICANTS AND FUEL) through filler port 3.
- The level is correct when the oil level is flush with the edge of opening 2.
- Check for any possible leaks at the drain plugs.
- Refit and tighten level plug 2 (tightening torque 34 to 49 N.m) and filler plug 3 (tightening torque 34 to 49 N.m).
- Repeat this operation for the rear axle differential.

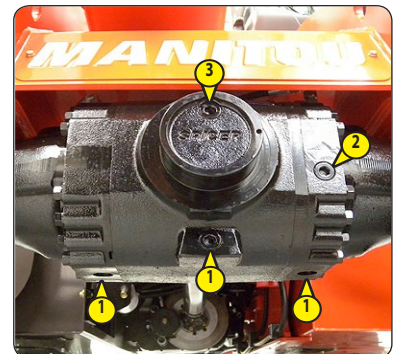

REPLACE

Hydraulic return oil filter cartridge

Stop the engine and release the pressure from the systems by operating the hydraulic controls.

⚠ IMPORTANT ⚠

Thoroughly clean the outside of the filter and its surroundings before any operation to prevent any risk of polluting the hydraulic system. Tighten the body of the filter exclusively by hand and lock a quarter turn.

- Lift out protective casing 1.
- Unscrew the fastening screws of the cover 2.
- Wait a few moments while the oil flows into the tank.
- Remove the hydraulic return oil filter cartridge 3 and replace with a new one (see: 3 - MAINTENANCE: FILTERS CARTRIDGES AND BELTS).
- Make sure that the cartridge is correctly positioned and refit the cover 2.
- Refit the protective casing 3.

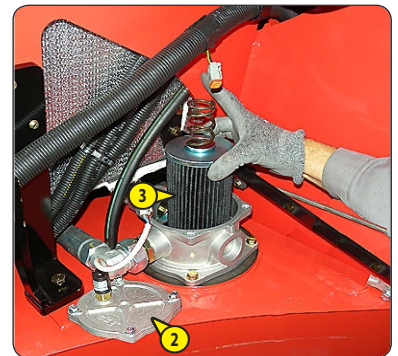

REPLACE

Cab ventilation filters

EXTERNAL CAB VENTILATION FILTER

- Remove protective casing 1 using the ignition key.
- Lift out cab ventilation filter 2 and replace it with a new one (see: 3 - MAINTENANCE: FILTERS, CARTRIDGES AND BELTS).
- Refit the protective casing.

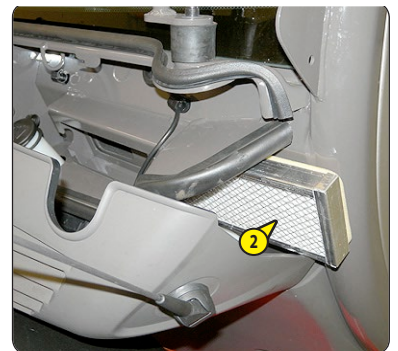

INTERNAL CAB VENTILATION FILTER

- Remove the protective grid 3.
- Lift out cab ventilation filter 4 and replace it with a new one (see: 3 - MAINTENANCE: FILTERS, CARTRIDGES AND BELTS).
- Refit the protective grid.

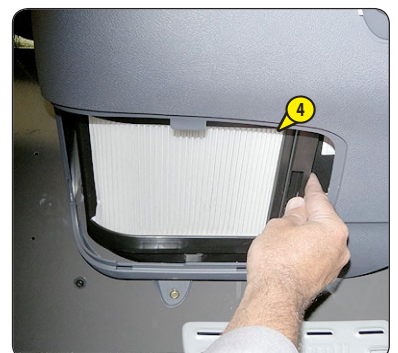

REPLACE

Fuel pre-filter

⚠ IMPORTANT ⚠

Carefully clean the outside of the pre-filter and its holder, to prevent dust from getting into the system.

Make sure the electrical contact on the telehandler is cut, otherwise fuel will be released if the lift pump is on.

- Open the engine bonnet.
- Carefully clean the outside of the filter and its holder, to prevent dust from getting into the system.
- Place a receptacle under the pre-filter and empty using drain plug 1.
- Remove container 2 and discard cartridge 3 as well as its seals.
- Clean the inside of the filter head and the housing, using a brush immersed in clean diesel oil.
- Lightly lubricate the new seals with clean engine oil and refit the assembly with a new cartridge (see: 3 - MAINTENANCE: FILTERS CARTRIDGES AND BELTS).
- Retighten tank 2 (tightening torque 14 N.m).

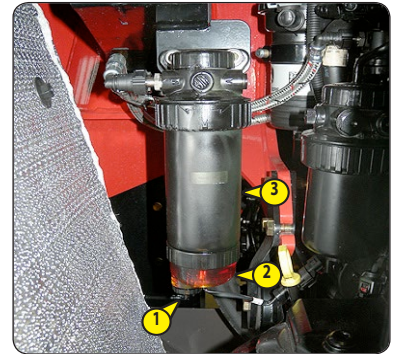

REPLACE

Fuel filter

⚠ IMPORTANT ⚠

Carefully clean the outside of the pre-filter and its holder, to prevent dust from getting into the system.

- Open the engine bonnet.
- Carefully clean the outside of the filter and its holder, to prevent dust from getting into the system.
- Place a receptacle under the filter and empty using drain plug 1.
- Loosen the filter 2 and discard it as well as its seals.
- Clean the inside of the filter head using a brush immersed in clean diesel oil.
- Lightly lubricate the new seals with clean engine oil and refit the assembly with a new filter (see: 3 - MAINTENANCE: FILTERS CARTRIDGES AND BELTS).
- Retighten the filter on its support (tightening torque 10 N.m).
- Start up the I.C. engine and make sure there is no leakage.

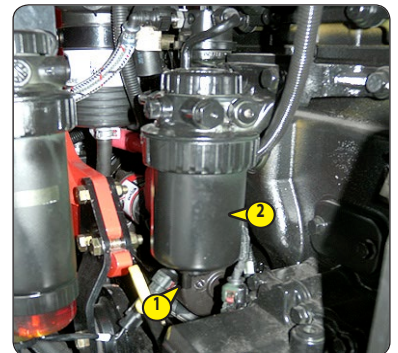

CHECK

Fork wear *

** Consult your dealer.*



Page intentionally left blank



1000 HOUR - PERIODIC MAINTENANCE - EVERY 1000 HOURS OF SERVICE OR 2 YEARS

IN ADDITION, CARRY OUT PERIODIC MAINTENANCE FOR 500 HOURS OF SERVICE.

CHECK

Safety belt

⚠ IMPORTANT ⚠

In no event should the lift truck be used if the seat belt is defective (fixing, locking, cuts, tears, etc.). Repair or replace the seat belt immediately.

SEAT BELT WITH TWO ANCHORING POINTS

- Check the following points:
 - Fixing of the anchoring points on the seat.
 - Cleanness of the strap and the locking mechanism.
 - Triggering of the locking mechanism.
 - Condition of the strap (cuts, curled edges).

REELED SEAT BELT WITH TWO ANCHORING POINTS

- Check the points listed above together with the following points:
 - The correct winding of the belt.
 - Condition of the reel guards.
 - Roller locking mechanism when the strap is given a sharp tug.

NOTE: After an accident, replace the seat belt.

REGENERATE



"Stationary telehandler" exhaust particle filter

⚠ IMPORTANT ⚠

Exhaust particle filter cleaning is an automated procedure activated by the operator when the help screens are displayed  .

Once the exhaust particle filter regeneration procedure is completed, leave the engine idling for a few minutes to lower the temperature before switching off the ignition.





- Park the telehandler in a safe and adequately ventilated place.
- Check the following points:
 - Forward/reverse selector in neutral,
 - Parking brake applied,
 - Jib angle less than 5°,
 - Engine water temperature greater than 60 °C.
- Check that there is sufficient fuel.
- Start the telehandler and run the engine for a few minutes to bring it up to its operating temperature.
- Press down on the top of switch 1 for more than two seconds to begin the regeneration procedure.
- The help screen  will be displayed, the indicator light  will come on, then a beep will sound to confirm that "stationary telehandler" particle filter regeneration is running. Failing this, the help screen  will appear and a beep will sound. Recheck the positioning of the telehandler and consult your dealer if necessary.

⚠ IMPORTANT ⚠

The exhaust particle filter regeneration procedure must only be stopped in case of necessity. If the operator presses the forward or reverse selector during regeneration, the procedure will automatically be halted. To properly interrupt the procedure, press the bottom of switch 1.

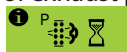
During the procedure, the engine speed is controlled by the engine electronic control unit.

- The time taken for exhaust particle filter regeneration to complete varies (between 20 and 50 minutes) according to various criteria, such as:
 - The level of clogging of the filter,
 - The ambient temperature,
 - The fuel quality and type of engine oil,
 - The number of exhaust particle filter automatic regeneration requests previously cancelled.
- The help screen  and the light  will come on when the regeneration procedure has finished. The engine speed returns to idle.

CLEAN

Place the lift truck on level ground with the engine stopped.

⚠ IMPORTANT ⚠

Do not smoke or approach with a flame during this operation.

Never attempt to carry out welding or any other operation by yourself, as this could cause an explosion or a fire.

- Inspect the parts susceptible to leaks in the fuel circuit and in the tank both visually and by touch.
- In the event of a leak, contact your dealer.
- Place a container under drain plug 1 and unscrew the plug.
- Open the fuel filler access panel with the ignition key.
- Remove filling plug 2 to ensure that the oil is drained properly.
- Rinse out with ten litres of clean diesel through filler port 3.
- Refit and tighten the drain plug (tightening torque 72 to 88 N.m).
- Fill the fuel tank with clean diesel filtered through the filler port.
- Refit the filler plug.

Fuel tank

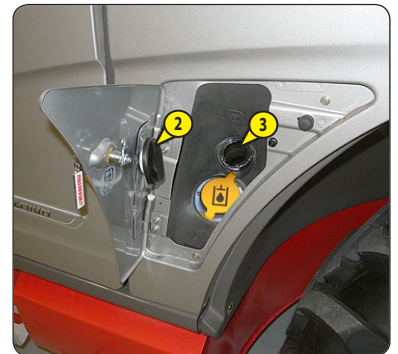
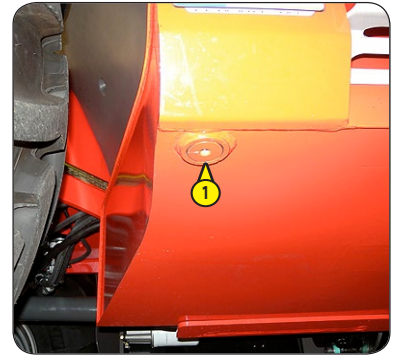

REPLACE

Cooling liquid

These operations are to be carried out if necessary or every two years at the beginning of winter. Place the telehandler on level ground with the I.C. engine stopped and cold.

⚠ IMPORTANT ⚠

The I.C. engine does not contain any corrosion resistor and must be filled during the whole year with a mixture containing 25 % of ethylene glycol-based antifreeze.

DRAINING THE LIQUID

- Open the engine bonnet.
- Open the panel 1 under the drain plug 2 with the lever 3.
- Set a container under drain plug 2 on the radiator and drain plug 4 of the engine block and loosen them.
- Take drain hose 5.
- Place the end of the drain hose in the container and screw the hose fully to the drain connector 2.
- Remove filler plug 6 from the expansion tank and fully open the heating control to ensure proper emptying.
- Let the cooling circuit drain entirely while ensuring that the ports do not get clogged.
- Check the condition of the hoses as well as the fastening devices and change the hoses if necessary.
- Rinse the circuit with clean water and use a cleaning agent if necessary.

FILLING THE LIQUID

- Remove, clean and refit drain hose 5.
- Refit and tighten drain plug 2 and drain plug 4.
- Open the radiator filler plug 7 and slowly fill the circuit with the cooling liquid (see: 3 - MAINTENANCE: LUBRICANTS AND FUEL) through the filler port.
- Retighten the radiator filler plug 7.
- Top up the cooling circuit level up to the centre of the expansion tank 8 via filler port 9.
- Refit filler plug 6.
- Run the engine at idle for a few minutes.
- Check for any possible leaks.
- Close the panel with the lever 3.
- Check the level and refill if necessary.

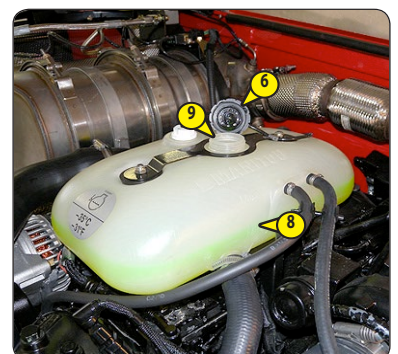
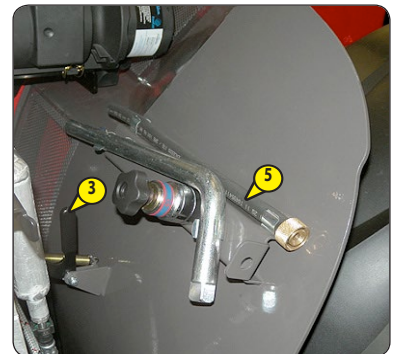
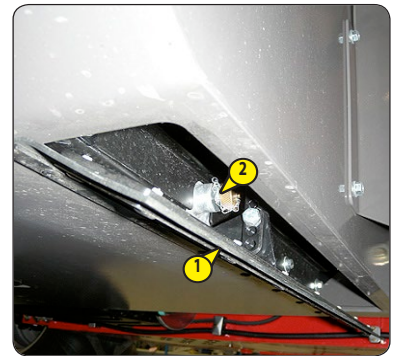

TABLE FREEZING POINT OF THE VARIOUS % VOLUMES OF ANTIFREEZE AND WATER

Antifreeze	Water (distilled for preference)	Freezing temperature
25%	75%	-14 °C
35%	65%	-23 °C
40%	60%	-27 °C
50%	50%	-40 °C (remplissage du Fabricant)

REPLACE

Dry air filter cartridge

In case of use in a heavily dust laden atmosphere, the cartridge replacement interval must be reduced (to 250 hours in a heavily dust laden atmosphere).

⚠ IMPORTANT ⚠

*Change the cartridge in a clean location, with the engine stopped.
Never operate the telehandler without the air filter or with the air filter damaged.*

If the air filter clogging indicator light comes on , replace the cartridge with minimum delay (maximum 1 hour).

- Open the engine bonnet.
- Loosen the bolts and remove cover 1.
- Pivot cartridge 2 towards the front and carefully remove to avoid spilling the dust.
- Leave the safety cartridge in place.
- The following parts must be cleaned with a damp, clean lint-free cloth.
 - The inside of the filter and cover.
 - The inside of the filter inlet hose.
 - The gasket surfaces in the filter and in the cover.
- Check pipes and connections between the air filter and the engine and the connection and state of the clogging indicator on the filter.
- Before mounting, check the state of the new filter cartridge (see: 3 - MAINTENANCE: FILTERS, CARTRIDGES AND BELTS).
- Tilt the cartridge approximately 5° towards the front, insert it into the filter and position it by pressing the edges and not the middle.
- Refit the cover and ensure that the clips are properly secured. The cover should fit on easily, if this is not the case, check the position of the cartridges in the filter.



REPLACE

Engine crankcase ventilation filter

- Open the engine bonnet.
- Carefully clean the outside of the filter and its holder, to prevent dust from getting into the system.
- Loosen filter 1 and discard it as well as its seal.
- Lightly lubricate the new seals with clean engine oil and refit the assembly with a new filter (see: 3 - MAINTENANCE: FILTERS CARTRIDGES AND BELTS).
- Retighten the filter on its support (tightening torque 10 N.m).

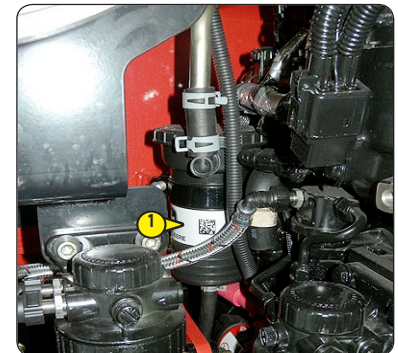

REPLACE

Front wheel reducer oil

REPLACE

Rear wheel reducer oil

Place the lift truck on level ground with the engine stopped and the reducers' oil still warm.

⚠ IMPORTANT ⚠

Dispose of the drain oil in an ecological manner.

- Drain and change the oil of each wheel reduction gear.
- Place drain plug 1 in position A.
- Place a container under the drain plug and unscrew the plug.
- Let the oil drain fully.
- Place the drain port in position B, i.e. in a level port.
- Fill up with oil ( LUBRICANTS AND FUEL) through level 1 filler port.
- The level is correct when the oil level is flush with the edge of the hole.
- Refit and tighten the drain plug (tightening torque 34 to 49 N.m).



REPLACE

Gear box oil

CLEAN

Speed sensor

⚠ IMPORTANTE ⚠

Operation to be carried out the first time after 100 hours of service, periodically every 1000 hours of service.

Position the forklift on level ground, with the engine switched off and the oil in the gearbox still hot. Place a container under the drainage plug 1 (E11). Unscrew plug 1 (E11) and let the oil flow out. Remove the filler plug 2 (E11) to ensure complete drainage. Refit the plug and tighten it 1 (E11) (35-50 N · m).

Speed sensor cleaning 5 (E11/1):

- Loosen the screw and remove the speed sensor 5.1 (E11/1).
- Loosen the screw and remove the speed sensor 5.2 (E11/1).
- Install the speed sensor (Loctite 270), and tighten the screw to a torque of 9,5 - 11 N·m 5.3 (E11/1).
- Install the speed sensor (Loctite 270), and tighten the screw to a torque of 9,5 - 11 N·m 5.4 (E11/1).

Fill the cup with the right quantity of new hydraulic oil (see: 3 - MAINTENANCE: LUBRICANTS AND FUEL) through the filler hole 3 (E11).

Refit the filler plug 2 (E11) (35-50 N · m).

When the oil is hot, check the level and top up, if necessary.

The level is correct when the oil level is flush with the edge of the hole 3 (E11).

Check for leakage from the drainage plug 1 (E11).

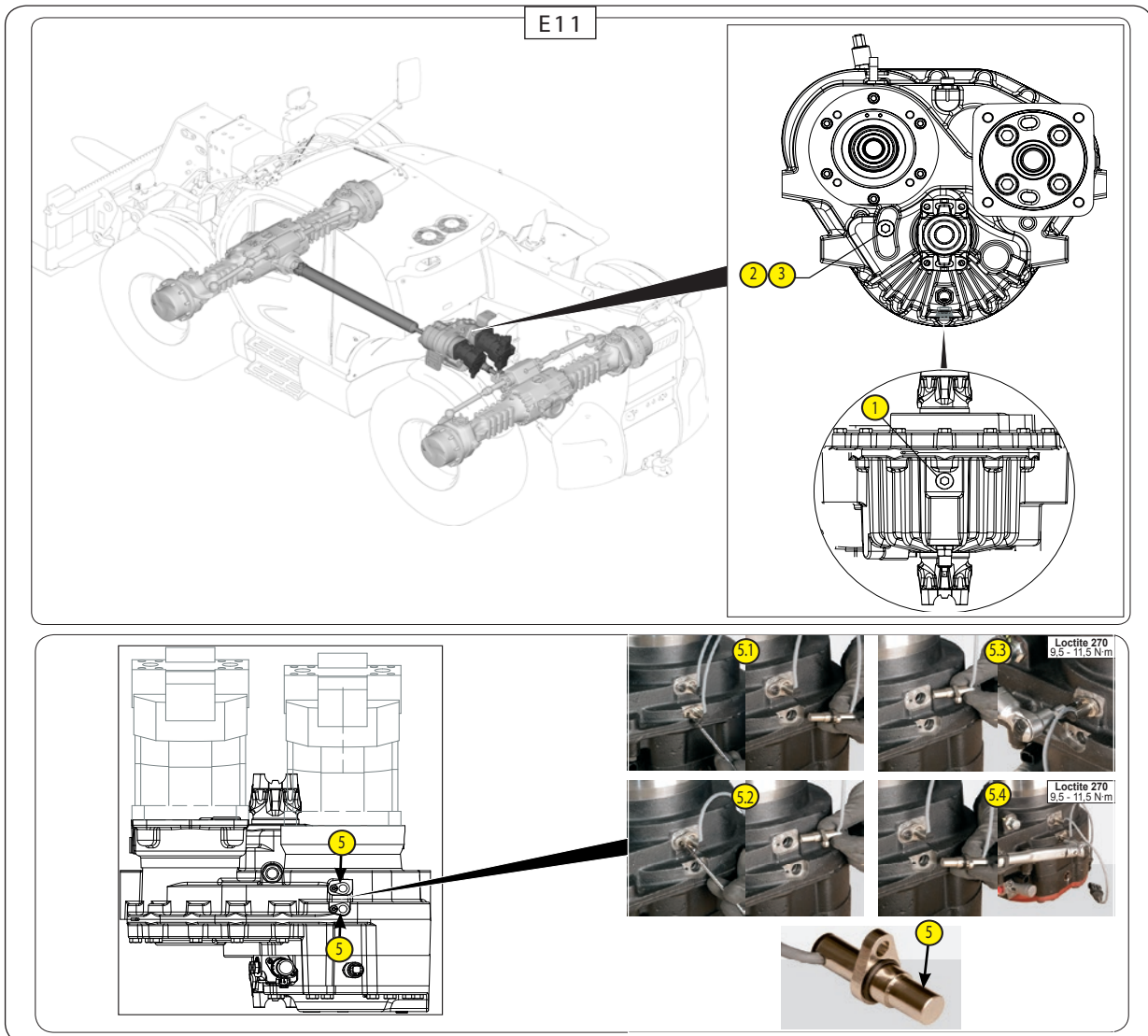



CHECK	Engine silent blocks *
CHECK	Gearbox silent blocks *
CHECK	Gearbox controls *
CHECK	Brake system pressure *
CHECK	Jib pads wear *
CHECK	Condition of wiring harness and cables *
CHECK	Lights and signals *
CHECK	Alarms *
CHECK	Condition of the rear view mirrors *
CHECK	Structure of the cab *
CHECK	Structure of the chassis *
CHECK	Attachment carriage *
CHECK	Condition of attachments *
REPLACE	Brake oil *
BLEED	Brake circuit *
ADJUST	Brake *

** Consult your dealer.*

2000 HOUR - PERIODIC MAINTENANCE - EVERY 2000 HOURS OF SERVICE OR 4 YEARS

IN ADDITION, CARRY OUT PERIODIC MAINTENANCE FOR 500 HOURS OF SERVICE AND 1000 HOURS OF SERVICE.

CHECK

Wheel nut tightening torques

- Check the condition of the tyres, to detect cuts, blisters, wear, etc.
- Check the tightening torque of the wheel nuts with a torque wrench:
 - Front wheels: 630 Nm ± 94 N.m
 - Rear wheels: 630 Nm ± 94 N.m

REPLACE

Hydraulic oil

CLEAN

Inlet strainer for hydraulic fluid reservoir

REPLACE

Breather for the hydraulic oil tank

Place the telehandler on level ground with the I.C. engine stopped and telescope telescopic boom retracted and lowered as far as possible.

⚠ IMPORTANT ⚠

Before any intervention, thoroughly clean the area surrounding the drain plug, the suction strainer and the outside of the filter on the hydraulic tank.

Use a clean container and funnel and clean the top of the oil drum before filling.

Dispose of the drain oil in an ecological manner.

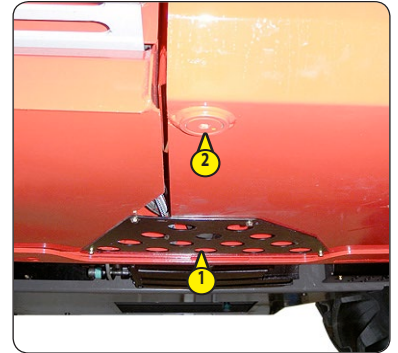

DRAINING THE OIL

- Lift out protective casing 1.
- Place a container under drain plug 2 and unscrew the plug.
- Open the hydraulic oil filler access panel with the ignition key.
- Remove the filler cap lock 12.
- Remove filling plug 3 to ensure that the oil is drained properly.

REPLACING THE BREATHER

- Unscrew the breather 4 and replace it with a new one (see: 3 - MAINTENANCE: FILTERS, CARTRIDGES AND BELTS).

CLEANING THE STRAINER

- Disconnect hose 5.
- Remove and clean the suction strainer 6 using a compressed air jet, check its condition and replace if necessary (see: 3 - MAINTENANCE: FILTERS CARTRIDGES AND BELTS).
- Refit the suction strainer making sure the seal is in the correct position.

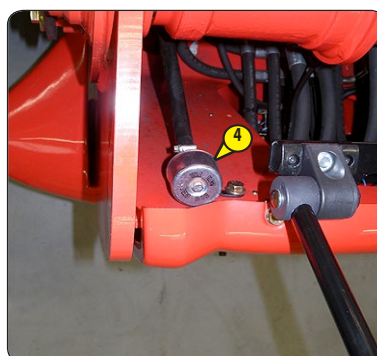



FILLING UP THE OIL

- Refit and tighten the drain plug 2 (tightening torque 29 to 39 N.m).
- Fill up with oil (see: 3 - MAINTENANCE: LUBRICANTS AND FUEL) through filler port 10.
- Observe the oil level on dipstick 11; the oil level should be at the level of the black point.
- Check for any possible leaks at the drain plug.
- Refit the filler plug 3.

HYDRAULIC CIRCUIT DECONTAMINATION

- Leave the engine running (accelerator pedal at halfway travel) for 5 minutes without using anything on the telehandler, then for 5 more minutes while fully using the hydraulic movements (except the steering system and the service brakes).
- Accelerate the engine at full speed for 1 minute, then activate the steering system and the service brakes.
- This operation makes a pollution abatement of the circuit possible through the hydraulic return oil filter.

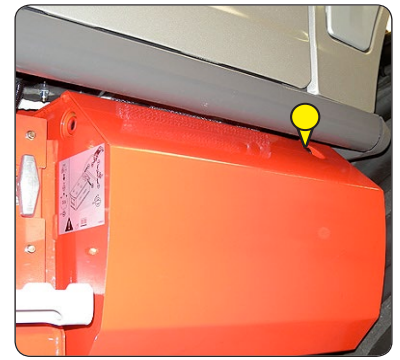



CHECK	Radiator *
CHECK	Transmission pressure *
CHECK	Steering *
CHECK	Steering swivel joints *
CHECK	Wear of the brake pads and the brake disk *
CHECK	Condition of boom assembly *
CHECK	Bearings and articulation rings *
CHECK	Condition of hoses and flexible pipes *
CHECK	Condition of cylinders (leakage, rods) *
CHECK	Hydraulic circuit pressures *
CHECK	Bearings and articulation rings *
CLEAN/CHECK	Air-conditioning (OPTIONAL) *

CLEANING CONDENSER AND EVAPORATOR COILS

CLEANING CONDENSATE TRAY AND RELIEF VALVE

COLLECTING COOLANT TO REPLACE FILTER-DRIER

REFILLING WITH COOLANT AND CHECKING THE THERMOSTATIC CONTROL AND PRESSURE SWITCHES

NOTE: When opening the evaporator unit, remember to replace the cover seal.

⚠ IMPORTANT ⚠

DO NOT ATTEMPT TO REPAIR ANY PROBLEMS YOURSELF. ALWAYS REFER TO YOUR DEALER WHEN REFILLING CIRCUITS, AS THEY HOLD THE CORRECT SPARE PARTS, AS WELL AS HAVING THE NECESSARY TECHNICAL KNOWLEDGE AND TOOLS.

In event of the following, contact a doctor.

In case of inhalation, move to fresh air.

In case of skin contact, wash immediately with plenty of water.

In case of frostbite, apply a sterile dressing.

In case of contact with eyes, rinse with clear water for 15 minutes.

IMPORTANT INFORMATION ABOUT THE COOLANT USED

- This product contains fluorinated greenhouse gases covered by the Kyoto Protocol.
 - Type of coolant: R134A; it is colourless, odourless and heavier than air. Its GWP (Global Warming Potential) is 1,430.
 - Do not allow the gases to escape into the atmosphere. Do not under any circumstances open the circuit, as this could cause loss of coolant.
- The compressor has a fluid level gauge; never unscrew this gauge because it would depressurise the system. The fluid level should only be checked when draining the system.

REPLACE	Compressor belt (air conditioning OPTION) *
----------------	--

** Consult your dealer*



Page intentionally left blank



➔ ④ **3000 HOUR - PERIODIC MAINTENANCE - EVERY 3000 HOURS OF SERVICE OR 6 YEARS**

IN ADDITION, CARRY OUT PERIODIC MAINTENANCE FOR 500 HOURS OF SERVICE AND 1000 HOURS OF SERVICE.

REPLACE

Safety dry air filter cartridge

- For the disassembly and reassembly of the dry air filter cartridge, see: 3 - MAINTENANCE: D3 - AIR FILTER CARTRIDGE.
- Gently remove the dry air filter safety cartridge 1, taking care to avoid spilling the dust.
- Clean the gasket surface on the filter with a damp, clean lint-free cloth.
- Check the condition of the new safety cartridge before fitting (see: 3 - MAINTENANCE: FILTERS CARTRIDGES AND BELTS).
- Place the cartridge into the filter and position it by pressing the edges, not the middle.

NOTE: The periodicity for changing the safety cartridge is given for information only. It must be changed once for every three changes of the dry air filter.

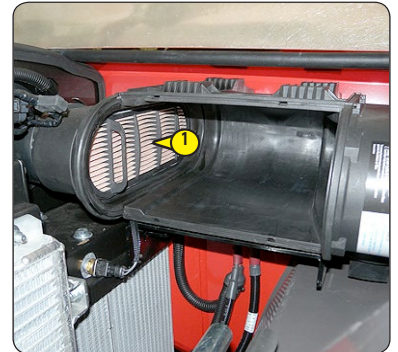

➔ ⑤ **4000 HOUR - PERIODIC MAINTENANCE - EVERY 4000 HOURS OF SERVICE OR 8 YEARS**

IN ADDITION, CARRY OUT PERIODIC MAINTENANCE FOR 500 HOURS OF SERVICE AND 1000 HOURS OF SERVICE.

REPLACE

DEF (Diesel Exhaust Fluid) feed pump filter

Position the telehandler on level ground with the engine stopped..

⚠ IMPORTANT ⚠

"DEF" is corrosive, protect the bodywork and wear personal protective equipment (gloves and goggles).

Clean the outside of the pump to prevent dust from entering the system.

- Turn off the engine of the telehandler and wait for the pump to stop.
- Remove the guard 1.
- Unscrew the cover of pump 2, remove and discard compensation element 3.
- Insert the end of tool 4 for the "DEF" supply filter into the filter 5 until it clicks, to indicate that tool 4 is fully inserted.
- Pull out tool 4 and filter 5 from the "DEF" supply pump. Remove filter 5.
- Lubricate the O-rings of the "DEF" filter.
- Replace filter 5 with a new filter (see: 3 - MAINTENANCE: filter elements and belts).
- Insert filter 5 carefully in the "DEF" dosing pump,
- install compensation cartridge 3 into filter 5 of the DEF dosing pump,
- Install and tighten the cap of filter 2 onto the dosing pump unit with the specified torque (torque 23 Nm).

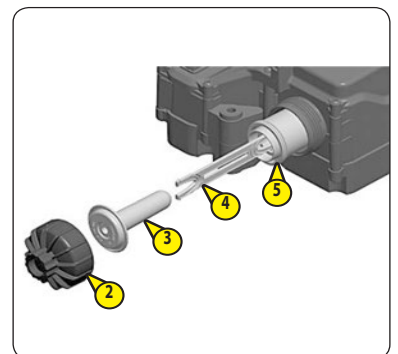

➤ OCCASIONAL MAINTENANCE

REPLACE

Wheels

For this operation, we advise you to use the hydraulic jack (MANITOU P/N 505507) and the safety support prop (MANITOU P/N 554772).

⚠ IMPORTANT ⚠

In the event of a wheel being changed on the public highway, secure the lift truck vicinity:

- Stop the lift truck, if possible on firm, level ground.
- Shut down the lift truck (⚠ 1 - OPERATING AND SAFETY INSTRUCTIONS: DRIVING INSTRUCTIONS UNLADEN AND LADEN).
- Switch on the hazard warning lights.
- Immobilise the lift truck in both directions on the axle opposite to the wheel to be changed.
- Unlock the nuts of the wheel to be changed.
- Place the jack under the flared axle tube, as near as possible to the wheel and adjust the jack.
- Raise the wheel until it is clear of the ground and place the safety support under the axle.
- Completely unscrew the wheel nuts and remove them.
- Free the wheel by reciprocating movements and roll it to the side.
- Slip the new wheel on the wheel hub.
- Hand-tighten the nuts, grease them if necessary.
- Remove the safety support and lower the lift truck with the jack.
- Tighten the wheel nuts with a torque wrench (⚠ 2000 HOUR - PERIODIC MAINTENANCE - EVERY 2000 HOURS OF SERVICE OR 4 YEARS) for tightening torque.



ADJUST

Front headlights

RECOMMENDED SETTING

(as per standard ECE-76/756 76/761 ECE20)

Adjustment of -2 % of the dipped beam relative to the horizontal axis of the headlight.

ADJUSTMENT PROCEDURE

- Place the unladen lift truck in the transport position and perpendicular to a white wall on flat, level ground.
- Check the tyre pressure (⚠ 2 - DESCRIPTION: TYRES).
- Place the forward/reverse selector in neutral.

CALCULATING THE HEIGHT OF THE DIPPED BEAM (H2)

- h1 = Height of the dipped beam in relation to the ground.
- h2 = Height of the adjusted beam.
- l = Distance between the dipped beam and the white wall.

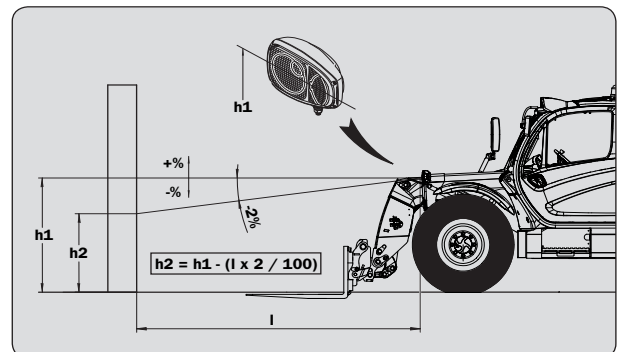



RESETTING

Longitudinal stability limiter and warning device









According to the use of the telehandler, the device may require to be periodically reset. This procedure simplifies the operation.





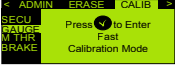





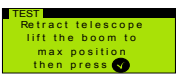

Carefully follow the boom positioning instructions.

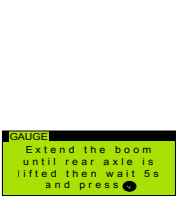
The appearance of the screen  indicates that an instruction, a cancellation request  or a late response has not been observed. If in doubt, consult your dealer.

When the reset is completed, check the operation of the longitudinal stability limiter and warning device (see: 3 - MAINTENANCE: A - DAILY OF EVERY 10 HOURS SERVICE).

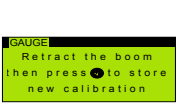
- Provide a fork carrier or a bucket and a load corresponding to at least half the telehandler's rated capacity.
- Preferably perform the reset when the telehandler is still cold (before it is used) or ensure that the temperature of the rear axle is not more than 50°C.
- Place the telehandler on flat, level ground with the wheels straight.
- Press the button  to display the menu screen and navigate horizontally between menus using the buttons  and vertically in the sub-menus using the buttons  and .
- Display the GAUGE "reset strain gauge"  and confirm .
- Enter the CUSTOMER code  and validate .

<p>STAGE 1 ↓</p>		<p>- Fully raise the telescopic boom with the telescopes fully retracted.</p>	<p>Confirm </p>
<p>STAGE 2 ↓</p>		<p>- Calibration in progress...</p>	<p>Go to stage 3</p>
<p>STAGE 3 ↓</p>		<p>- Fully lower the telescopic boom with the engine running at full revs and the hydraulic control at the maximum setting.</p>	<p>Confirm </p>
<p>STAGE 4 ↓</p>		<p>- With the fork carriage or the bucket and a load. Jib fully retracted in the lowered position, approximately 20 centimetres from the ground.</p>   <p>IMPORTANT</p> <p>- Keep the load as close to the ground as possible throughout this operation.</p> <p>- Hold down the disable the "aggravating" hydraulic movement cut-off button  (indicator lamp lit), and telescope the telescopic boom until the rear wheels leave the ground.</p>	<p>Wait 5 seconds and validate </p>
<p>FINISH</p>		<p>- Retract the telescopes to restore the situation.</p>	<p>Check  to save the new parameters</p>

REPLACE

Alternator belt

- Open engine bonnet and the lower cover 1.
- Remove the protective casing 2.
- Place a 1/2 in. socket wrench in the square of the automatic tensioner 3 to slacken the belt and remove it.
- Release the force and remove the socket wrench.
- Refit a new alternator belt (see: 3 - MAINTENANCE: FILTERS CARTRIDGES AND BELTS) ensuring that it is properly seated in the grooves of each pulley and tighten the belt using the automatic tensioner 3.

NOTE: Take advantage of belt removal to check the correct operation of the pulleys and bearings (noise, rubbing, play, etc...).

- Refit the protective casing 2.

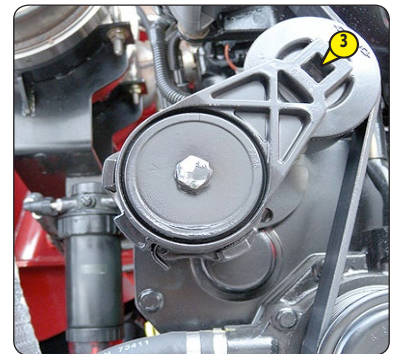



CLEAN

DEF (Diesel Exhaust Fluid) tank

* Consult your dealer

⚠ IMPORTANT ⚠

If the "DEF" tank cap is opened at high temperatures, ammonia vapours may escape. Ammonia vapours have a pungent odour and are particularly irritating to

- the skin
- the mucous membranes
- the eyes

The presence of such vapours can result in burning eyes, nose, and oral cavities, as well as coughing and tearing.
Avoid inhaling ammonia vapours.

⚠ IMPORTANT ⚠

"DEF" must not come into contact with skin, eyes or clothing.

- If the "DEF" comes into contact with your eyes or skin, rinse affected areas with clean water immediately.
- If the "DEF" is swallowed, immediately rinse your mouth out with a lot of clean water and drink plenty of water.
 - Change clothing that is soiled with "DEF" immediately.
 - If allergic reactions occur, consult a doctor immediately.

Keep the "DEF" out of the reach of children.

⚠ IMPORTANT ⚠

The "DEF" lines and all connected components are pressurised during operation and could be hot, even after the engine has been switched off. There is a risk of burns.

When opening the pressurised system, there is a risk of scalding due to hot "DEF" spraying out.

- Wait at least 5 minutes after switching off the engine before starting to work on the exhaust gas after-treatment system.
- Open line connections and caps on system components slowly. Cover the area that you are disconnecting with a cloth.
 - Wear suitable protective gloves, protective clothing and safety goggles.

If the "DEF" gets into the coolant circuit (even minute amounts), thermostats and temperature sensors will be damaged.

- Always keep the "DEF" completely separate from other service products.
- Do not use the same containers and fluid collecting pans for the "DEF" and other service products.
 - Do not continue to use service products that contain traces of "DEF".

Individual components of the SCR system react very sensitively to even the slightest trace of impurities in the "DEF".

- Only use containers and fluid collecting pans that are clean and suitable for the "DEF".
 - Do not continue to use "DEF" which contains traces of impurities.

⚠ IMPORTANT ⚠

Fire fighting measures the "DEF" is not flammable. In the event of a fire, NH₃ (ammonia) may be released. This may result in a risk of poisoning. Measures to extinguish a fire must therefore be adapted to suit the surroundings.

⚠ IMPORTANT ⚠

Environmental note
Disposal of the "DEF":

- Even a small amount of spilled "DEF" can be an issue. The product is easily biodegradable and can be disposed of in the sewage system without issues by using a lot of water.
 - Packaging that is contaminated with "DEF" residue must be treated in the same way as the "DEF".
- Packaging that is contaminated with "DEF" residue must be treated in the same way as the "DEF". Packaging should be emptied as thoroughly as possible, cleaned appropriately and then reused.



- Remove the DEF tank* 1.
- Inspect the parts of the DEF circuit and the tank liable to leak, both visually and by touch*.
- In the event of a leak, contact your dealer.*
- Remove from the DEF tank 1:
 - the drain plug 2 (if necessary completely empty the tank from the DEF)*;
 - the cap 3 and the filler neck 3a*;
 - the suction unit 4*;
 - the vent filter 5*.

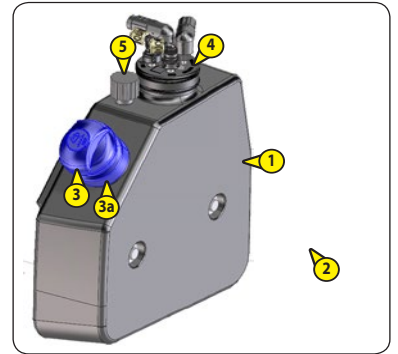
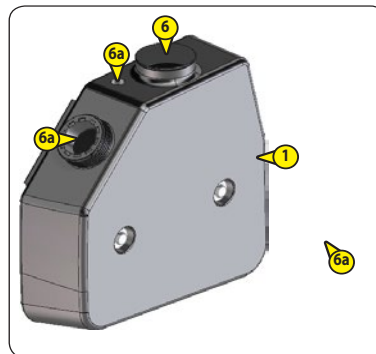
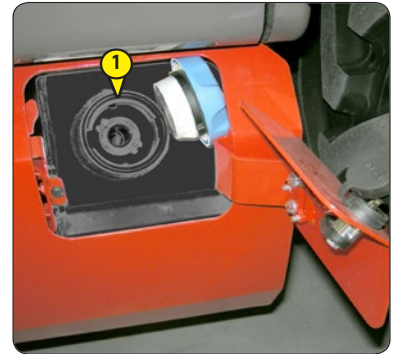

CLEAN THE "DEF" TANK*

Example of procedure:

- insert a cold water pipe into a DEF tank opening 6 and rotate the pipe 7 to direct the water to all the inside points of the tank 1 and make sure that water is leaking from the other openings 6a. Repeat the operation for at least 30 seconds.

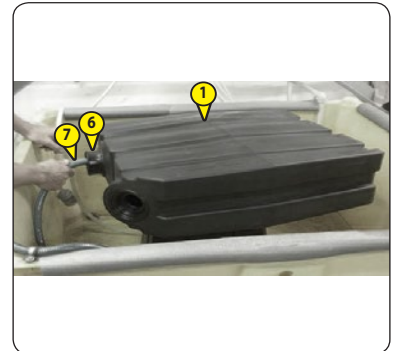

- Repeat the same operation with hot water pipe 8 and rotate the pipe to direct the water to all the inside points of the tank make sure that water is leaking from the other openings. Repeat the operation for at least 30 seconds.



- Close the DEF tank openings after blowing them, avoiding the introduction of foreign particles.

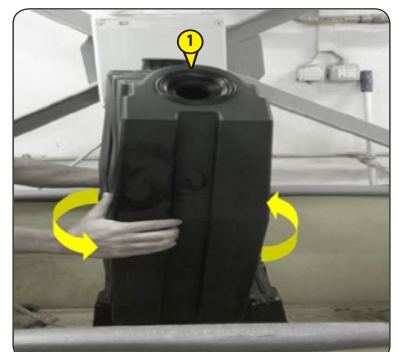

- Pour 2 liters of distilled water 9 in the DEF tank 1 and shake it for at least 1 minute.
- For an immediate check on the internal tank cleaning, pour 1 liter of distilled water 9 in the DEF tank 1 and shake it for 30 seconds.
- Empty the water through the nylon filter 10 to visually check for the presence of larger or smaller particles. Repeat the procedure when detecting the high presence of foreign particles. Clean the filter before the next check (rinse and blow).

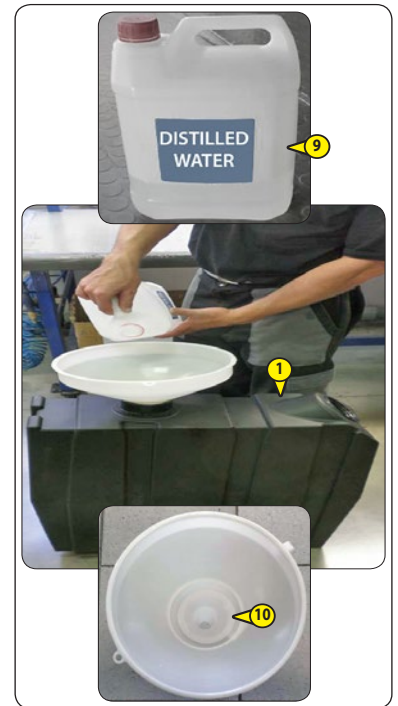

- Aspirate 11 the residual water inside the DEF tank 1.

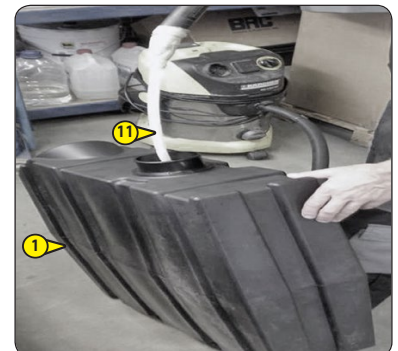

- Visually inspect the 12 inside DEF tank 1 cleaning (no water and contamination). If the tank is not visually clean, repeat the cleaning procedure.

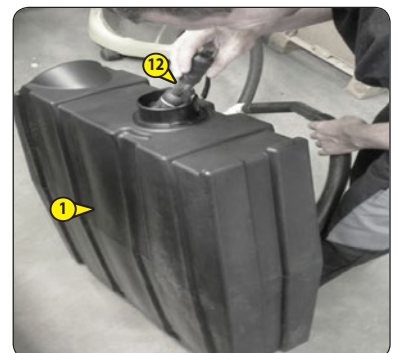

- Clean the outside of the DEF tank 1 using a dry cloth 13.



➔ OCCASIONAL OPERATION

TOWING OR WINCHING

Telehandler

⚠ IMPORTANT ⚠

Towing must be done at very low speeds for short distances.

- Position the gear selector in neutral position..
- Disengage the parking brake.
- Switch on the emergency lights.
- Activate the bypass function of the hydrostatic pump to allow at the hydraulic oil to flow freely.

To activate the bypass function:

- Switch off the combustion engine.
- Use an Allen key (WAF 8) to turn the shuttle valve (1) counter-clockwise to the stop (2).

The bypass function is now active.

- Immediately following towing, switch off the bypass function.

To deactivate the bypass function:

- Use an Allen key (WAF 8) to turn the shuttle valve (1) clockwise to the stop and tighten it with a tightening torque of 50 Nm.

The bypass function is no longer active.

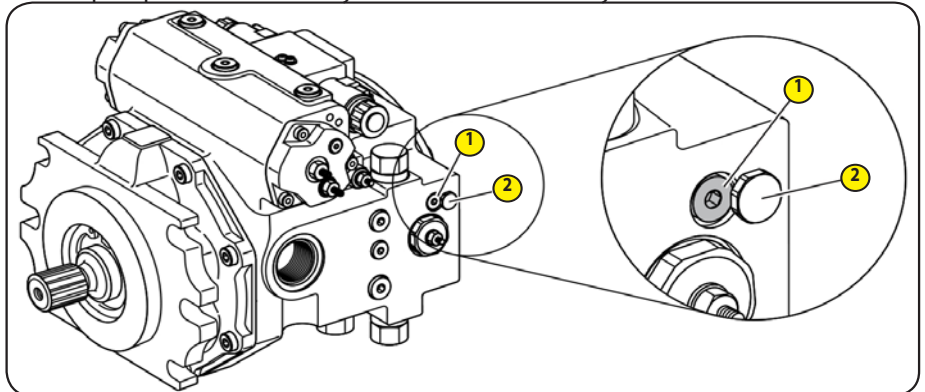

- Release the negative brake on front axle:

- Loosen nuts (2) of screws (3) provided for the mechanical and manual release of the braking units, then move the nuts backwards by approximately 8 mm.
- Tighten screws (3) to fasten them onto the pressure plate.
- Using a wrench, tighten the screws (3) in an alternate sequence by 1/4 turn at a time so as to compress the belleville washers and disengage the braking disks.

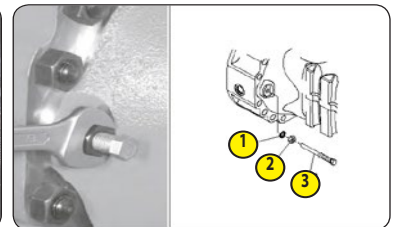

⚠ CAUTION ⚠

Tighten maximum by one turn.

- Adjust the negative brake on front axle:

- Remove screws (3) complete with nuts (2) and seals (1).
Replace seals, apply silicone-based Tecno Lube /101 grease to the screws and install all parts into the arm.
- Adjust screws (3) to obtain a distance of 34 ± 0.5 mm between axle machined surface and screw underhead.
- Lock into position with nuts (2).

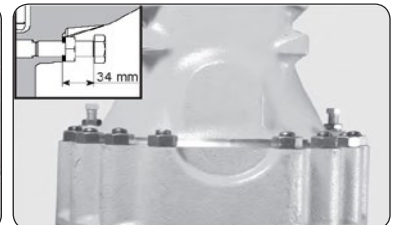
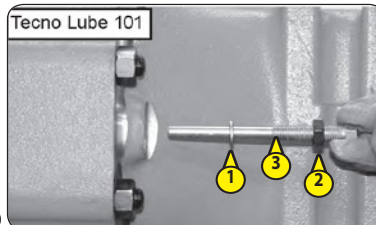

⚠ CAUTION ⚠

Hold screws (3) into position while locking the nuts (2); after locking, check the distance of screws (3) once more.

⚠ ATTENTION ⚠

The opposite screws must be tightened to the same extent.

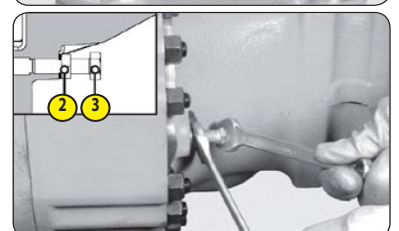

- In the absence of hydraulic servo-assistance of direction and brakes, act slowly but firmly on these two commands.
Avoid sudden, jerky movements.

SLINGING

Telehandler

- Take into account the position of the lift truck center of gravity for lifting.

A = 1632 mm (64.2 in)

B = 1248 mm (49.1 in)

- Place the hooks in the fastening points 1 provided.

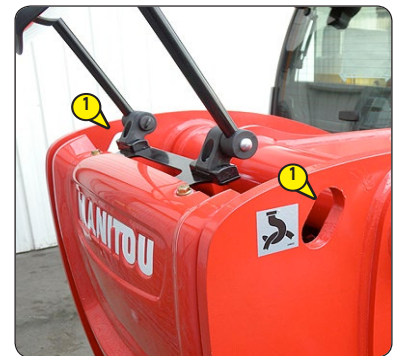
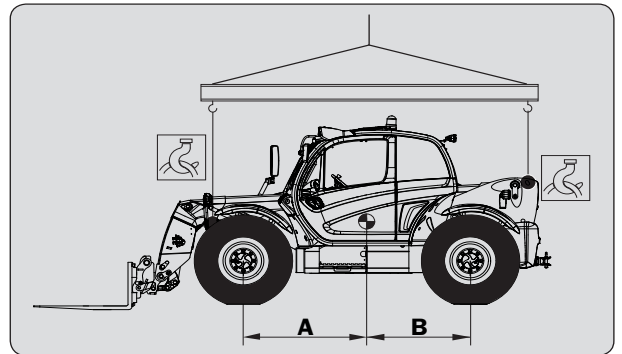



TRANSPORTING

Telehandler

⚠ IMPORTANT ⚠

Ensure that the safety instructions associated with the platform are complied with before loading the lift truck and that the driver of the carrier vehicle is informed of the dimensions and mass of the lift truck (↖ 2 - DESCRIPTION: CHARACTERISTICS). Ensure that the platform is of sufficient size and load capacity for transporting the lift truck. Check also the allowable ground contact pressure of the platform relative to the lift truck.

⚠ IMPORTANT ⚠

For lift trucks equipped with a turbo-charged I.C. engine, block off the exhaust outlet to avoid rotation of the turbo shaft without lubrication when transporting the vehicle.

LOADING THE LIFT TRUCK

- Block the wheels of the platform.
- Attach the loading ramps to the platform in such a way as to give the shallowest possible ramp angle for the lift truck.
- Load the lift truck parallel to the platform.
- Shut down the lift truck (↖ 1 - OPERATING AND SAFETY INSTRUCTIONS: DRIVING INSTRUCTIONS UNLADEN AND LADEN).

STOWING THE LIFT TRUCK

- Fix the chocks to the platform at the front and at the back of each tyre.
- Also fix the chocks to the platform on the inside of each tyre.
- Secure the lift truck to the platform with sufficiently strong ropes to the anchoring points 1 provided.
- Tighten the ropes.

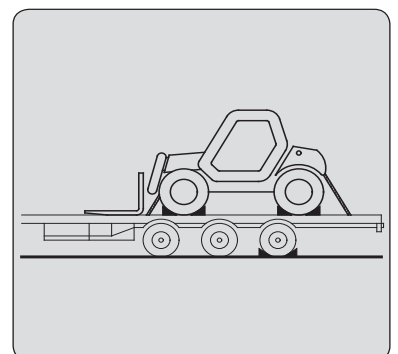
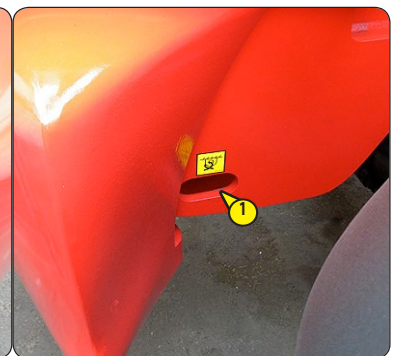
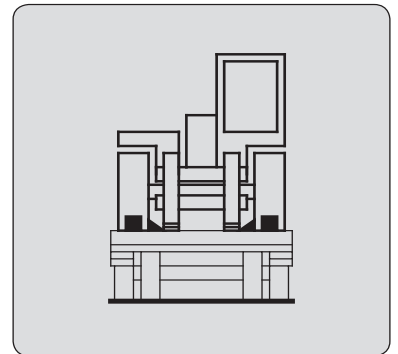
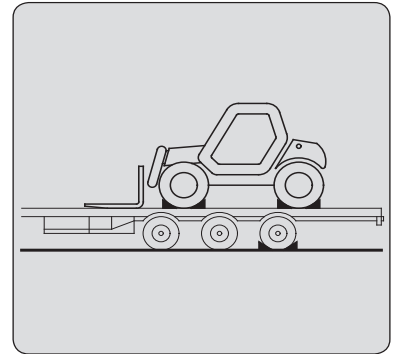



4 - OPTIONAL ATTACHMENTS FOR USE WITH THE RANGE





TABLE OF CONTENTS

4 - OPTIONAL ATTACHMENTS FOR USE WITH THE RANGE

<i>INTRODUCTION</i>	5
<i>PICKING UP THE ATTACHMENTS</i>	6
<i>TECHNICAL SPECIFICATIONS OF ATTACHMENTS</i>	8
<i>ATTACHMENT SHIELDS</i>	14





INTRODUCTION

- Your lift truck must be used with interchangeable equipment. These items are called: ATTACHMENTS.
- A wide range of attachments, specially designed and perfectly suitable for your lift truck is available and guaranteed by MANITOU.

⚠ IMPORTANT ⚠

Only attachments approved by MANITOU are to be used on our lift trucks

(see: 4 - ADAPTABLE ATTACHMENTS IN OPTION ON THE RANGE: TECHNICAL SPECIFICATIONS OF ATTACHMENTS).

The manufacturer's liability will be denied in case of modification or of attachment adaptation carried out without his knowing it.

- The attachments are delivered with a load chart concerning your lift truck. The operator's manual and the load chart should be kept in the places provided in the lift truck. For standard attachments, their use is governed by the instructions contained on this notice.

⚠ IMPORTANT ⚠

Maximum loads are defined by the capacity of a lift truck taking account of the attachment's mass and centre of gravity.

In the event of the attachment having less capacity than the lift truck, never exceed this limit.

- Some particular uses require the adaptation of the attachment which is not provided in the price-listed options. Optional solutions exist, consult your dealer.

⚠ IMPORTANT ⚠

Depending on their size, certain attachments may, when the boom is lowered and retracted, come into contact with the front tyres and cause damage to them, if reverse tilt is activated in the forward tilt direction.

TO REMOVE THIS RISK, EXTEND THE TELESCOPE TO A SUFFICIENT EXTENT FOR THE PARTICULAR LIFT TRUCK AND ATTACHMENT SO THAT THIS CONTACT IS NOT POSSIBLE.

SUSPENDED LOAD

⚠ IMPORTANT ⚠

Suspended load MUST be handled with a lift truck designed for that purpose

(see: 1 - OPERATING AND SAFETY INSTRUCTIONS: LOAD HANDLING INSTRUCTIONS: H - TAKING-UP AND SETTING-DOWN A SUSPENDED LOAD).

PICKING UP THE ATTACHMENTS

1 - ATTACHMENT WITHOUT HYDRAULICS AND HAND LOCKING DEVICE

TAKING UP AN ATTACHMENT

- Ensure that the attachment is in a position facilitating the locking to the carriage. If it is not correctly oriented, take the necessary precautions in order to move it safely.
- Check that the locking pin and the clip are in position in the bracket (fig. A).
- Place the lift truck with the boom fully lowered in front of and parallel to the attachment, tilt the carriage forwards (fig. B).
- Bring the carriage under the locking tube of the attachment, slightly lift the boom, incline the carriage backwards in order to position the attachment (fig. C).
- Lift the attachment off the ground to facilitate locking.

HAND LOCKING

- Take the locking pin and the clip on the bracket (fig. A) and lock the attachment (fig. D). Do not forget to refit the clip.

HAND RELEASING

- Proceed in the reverse order of paragraph HAND LOCKING while making sure you put back the locking pin and the clip in the bracket (fig. A).

LAYING AN ATTACHMENT

- Proceed in the reverse order of paragraph TAKING UP AN ATTACHMENT while making sure you place the attachment flat on the ground and in closed position.

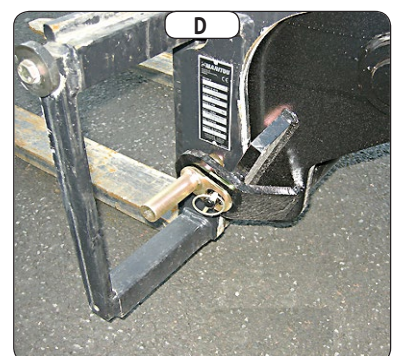
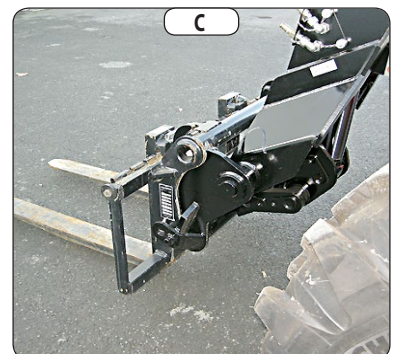
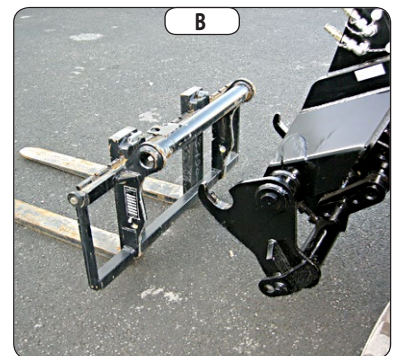
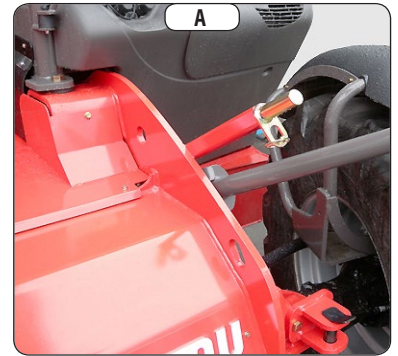

2 - HYDRAULIC ATTACHMENT AND MANUAL LOCKING DEVICE

TAKING UP AN ATTACHMENT

- Ensure that the attachment is in a position facilitating the locking to the carriage. If it is not correctly oriented, take the necessary precautions in order to move it safely.
- Check that the locking pin and the clip are in position in the bracket (fig. A).
- Place the lift truck with the boom fully lowered in front of and parallel to the attachment, tilt the carriage forwards (fig. B).
- Bring the carriage under the locking tube of the attachment, slightly lift the boom, incline the carriage backwards in order to position the attachment (fig. C).
- Lift the attachment off the ground to facilitate locking.

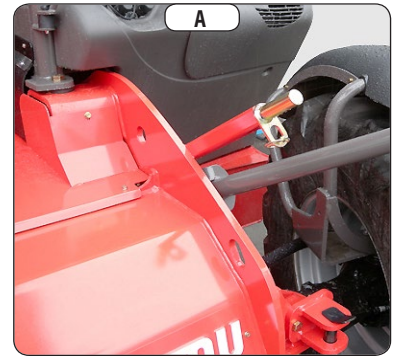



MANUAL LOCKING AND CONNECTION OF THE ATTACHMENT

⚠ IMPORTANT ⚠

Make sure that the rapid connectors are clean and protect the holes which are not used, with the caps provided.

- Take the locking pin and the clip on the bracket (fig. A) and lock the attachment (fig. D). Do not forget to refit the clip.
- Stop the I.C. engine and keep the ignition on the lift truck.

- Press for two seconds on the push-button  to release the attachment circuit hydraulic pressure. Screens  and  will be alternately displayed.

- Connect the rapid connectors according to the logic of the attachment's hydraulic movements.

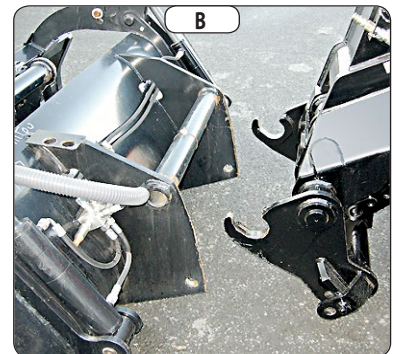

HAND RELEASING AND DISCONNECTING THE ATTACHMENT

- Proceed in the reverse order of paragraph HAND LOCKING AND CONNECTING THE ATTACHMENT while making sure you put back the locking pin and the clip in the bracket (fig. A).

LAYING AN ATTACHMENT

- Proceed in the reverse order of paragraph TAKING UP AN ATTACHMENT while making sure you place the attachment flat on the ground and in closed position.

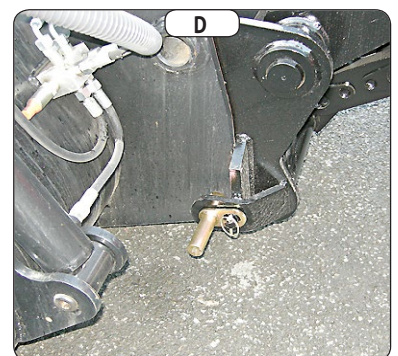
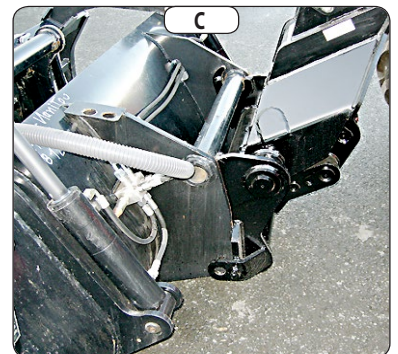



TECHNICAL SPECIFICATIONS OF ATTACHMENTS

FLOATING FORK CARRIAGE

	TFF 75 MT-1430
PART NUMBER	504280
Rated capacity	17637 lb
Width	61 in
Weight	1246 lb

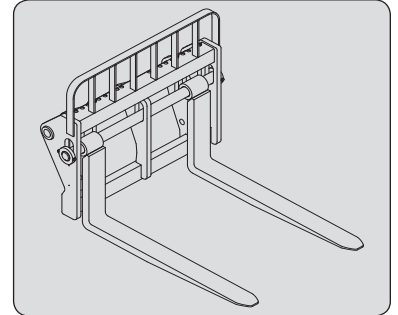

FLOATING FORK

	PART NUMBER		
Section	528083	578154	
Weight	7,8x2,3x47,2 in 414 lb	7,8x2,3x59 in 478 lb	

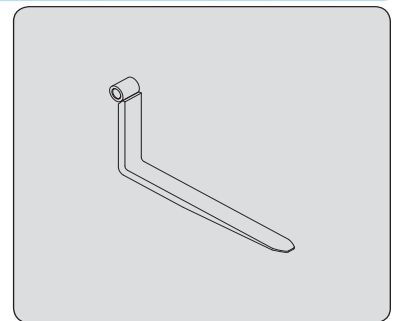



STANDARDISED SIDE-SHIFT CARRIAGE

	PFB FEM4 1200	PFB 75 MT-1750	PFB 75 MT-2000
PART NUMBER	732330	504107	527216
Rated capacity	17637 lb	17637 lb	17637 lb
Width	50 in	69 in	79 in
Weight	816 lb	1014 lb	1301 lb

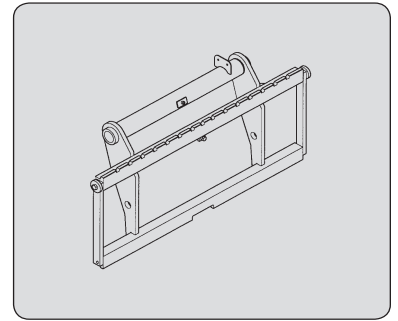

STANDARDISED SIDE-SHIFT CARRIAGE

	PFB 75 MT-1750+TDL	PFB 75 MT-2000+TDL
PART NUMBER	504365	566531
Rated capacity	16535 lb	16535 lb
Width	71 in	79 mm
Weight	1631 lb	1852 lb

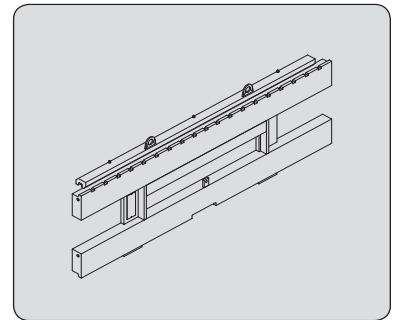

STANDARDISED FORK

	PART NUMBER	513110
Width		7,8x2,3x47,2 in
Weight		430 lb

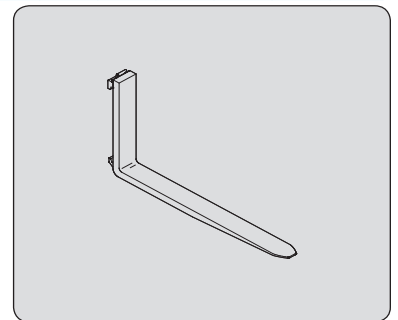



BENNE DE REPRISE

	CBR 1000 L2500
PART NUMBER	744050
Rated capacity	35 ft3
Width	98 in
Weight	1528 lb

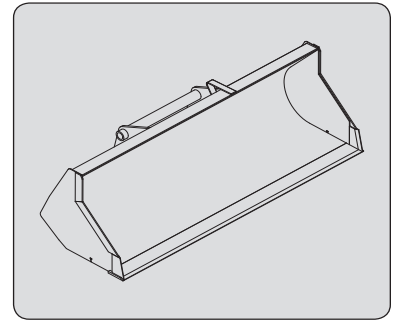

GRAIN BUCKET

	CBA 3200 L2500	CBA 4000 L2500	CBA 3000 L2450
PART NUMBER	52000125	52000060	790322
Rated capacity	113 ft3	141 ft3	103 ft3
Width	98 in	98 in	96 in
Weight	2447 lb	2315 lb	2061 lb

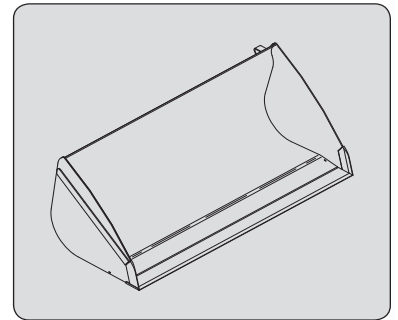

GRAB BUCKET

	CBG 2480/ 2600 MS	CBG 2480/ 2200 MS
PART NUMBER	790658	790657
Rated capacity	92 ft3	78 ft3
Width	98 in	98 in
Grab	-	-
Weight	2976 lb	2866 lb

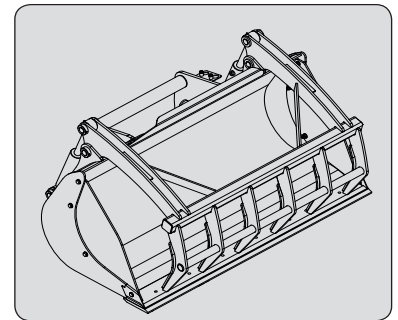

GRAB BUCKET

	CBG 2450 FO
PART NUMBER	790309
Rated capacity	40 ft3
Width	96 in
Grab	10
Weight	1720 lb

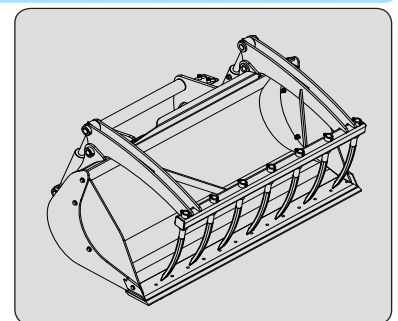

SWEEPER COLLECTOR WITH BRUSH

	BRB 2200	BRB 2500
PART NUMBER	790315	790316
Rated capacity	19 ft3	
Width	102 in	
Weight	2039 lb	

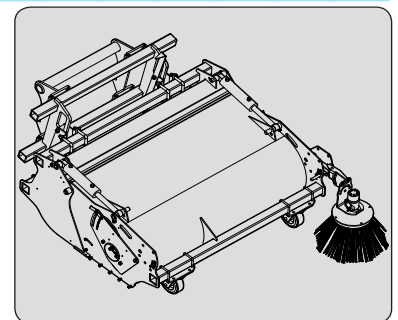



BALE CLAMP WITH GRAB

PART NUMBER	PBG 2X4
Rated capacity	2205 lb
Width	51 in
Grab	2x4
Weight	578 lb

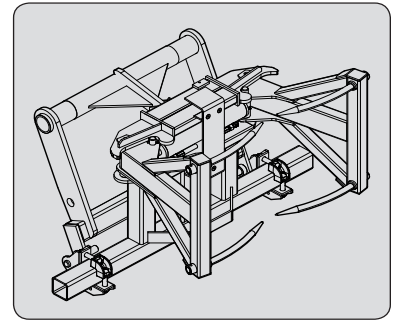

BALE CLAMP WITH GRAB

PART NUMBER	P2BG 2X4
Rated capacity	3307 lb
Width	43 in
Grab	2x4
Weight	606 lb

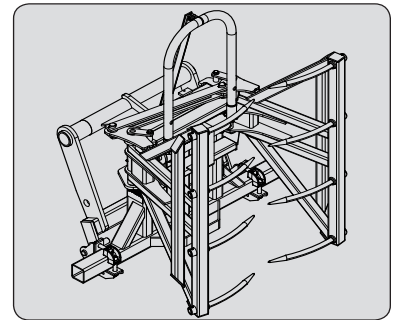

WRAPPED BALE CLAMP

PART NUMBER	MBC 2X3
Rated capacity	1764 lb
Width	47 in
Weight	639 lb

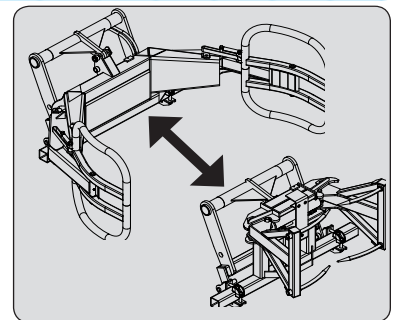

WRAPPED BALE CLAMP

PART NUMBER	PBE
Rated capacity	2205 lb
Width	63 in
Weight	533 lb

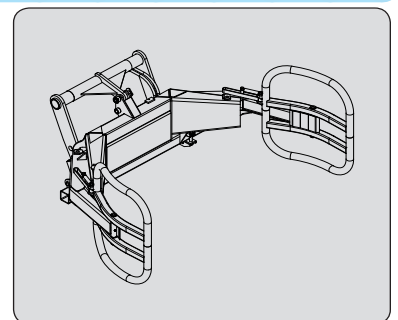



COQUE GRAPPIN DISTRIBUTEUR

PART NUMBER	FMG 2450/2000
Rated capacity	790534 4409 lb
Width	96 in
Forks	12
Grab	5
Weight	15212 lb

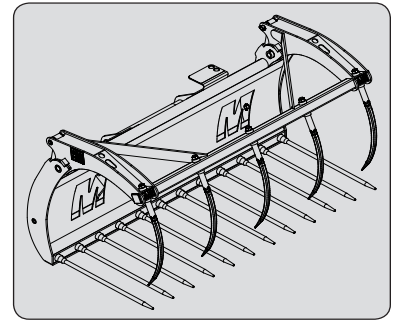

SIMPLE ROTOR SHELL

PART NUMBER	FB 1900/1700
Rated capacity	790699 3748 lb
Width	74 in
Forks	4
Weight	474 lb

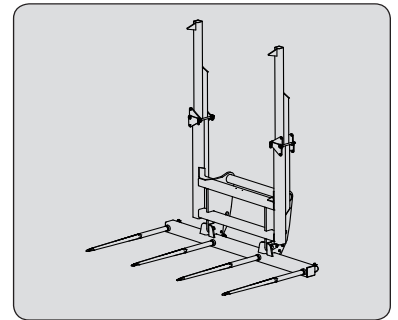



JIB WITH SWAN-NECK HOOK

MUST be used with a lift truck equipped with an operational hydraulic movement cut-out device.

PART NUMBER	PCR GM
Rated capacity	569548
Weight	8818 lb
	573 lb

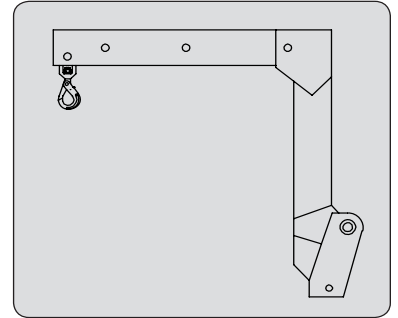

JIB WITH SWAN-NECK HOOK

MUST be used with a lift truck equipped with an operational hydraulic movement cut-out device.

PART NUMBER	PCRB GM
Rated capacity	673697
Weight	8818 lb
	507 lb

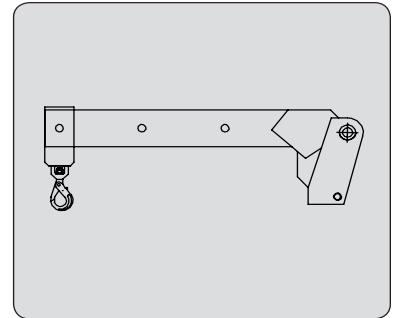

CRANE JIB

MUST be used with a lift truck equipped with an operational hydraulic movement cut-out device.

PART NUMBER	PC60
Rated capacity	939050
Weight	13228 lb
	287 lb

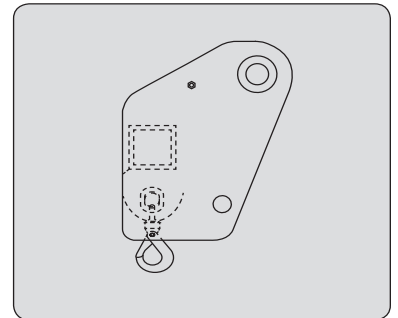

BIG BAG HANDLER

PART NUMBER	HBB 1500-2400
Rated capacity	931627
Width	5291 lb
Weight	57 in
	410 lb

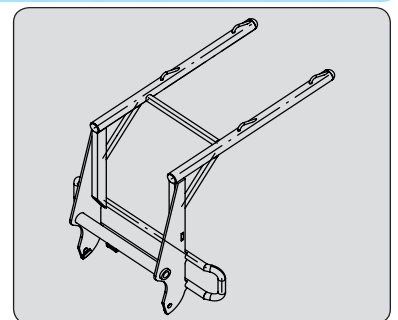





5 - LOAD CHARTS FOR INTERCHANGEABLE EQUIPMENT



PREAMBLE

⚠ IMPORTANT ⚠

The capacity charts are applicable only when the safety system is properly inserted.



MLT 960 104JD ST4 S2





MLT 960 104JD ST4 S2

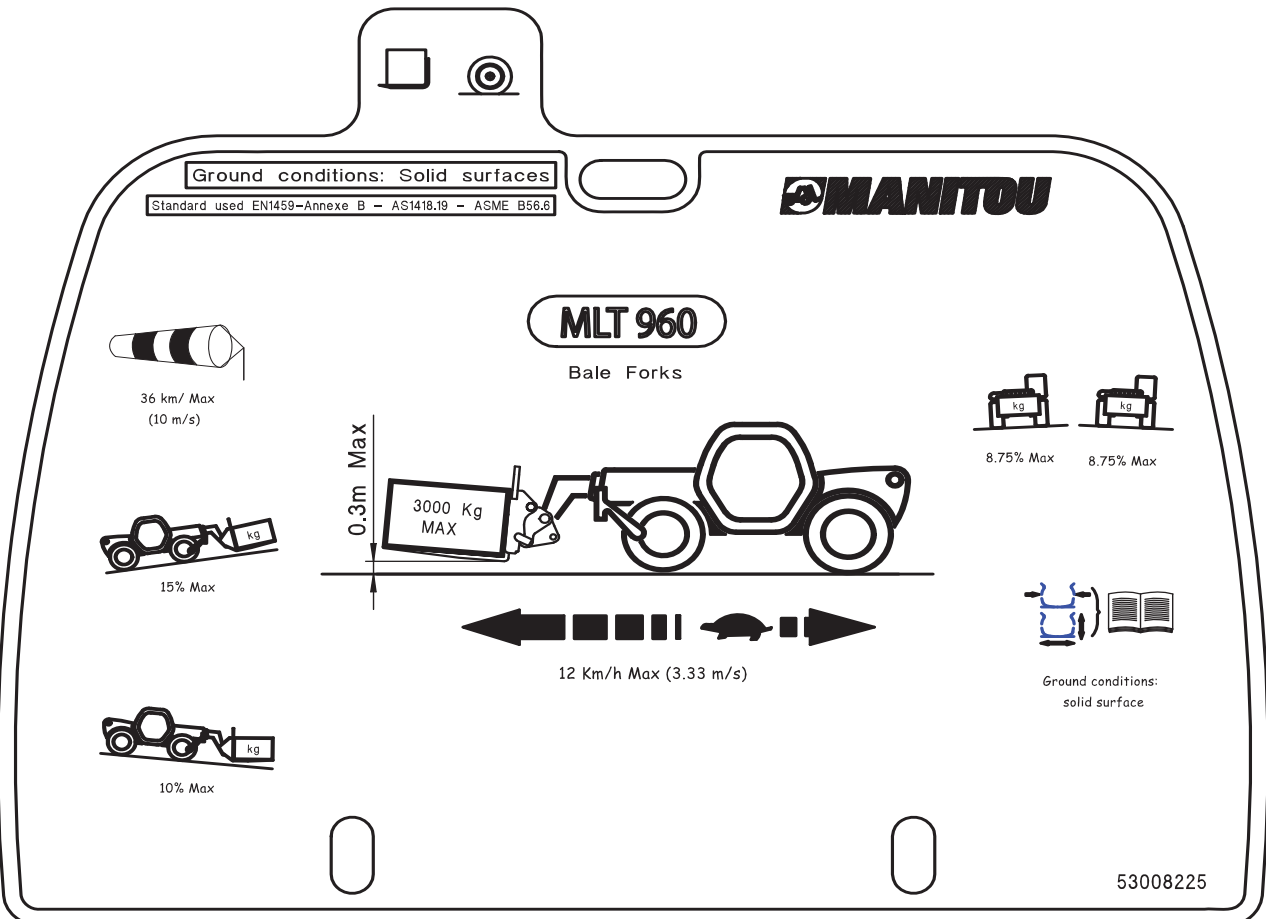
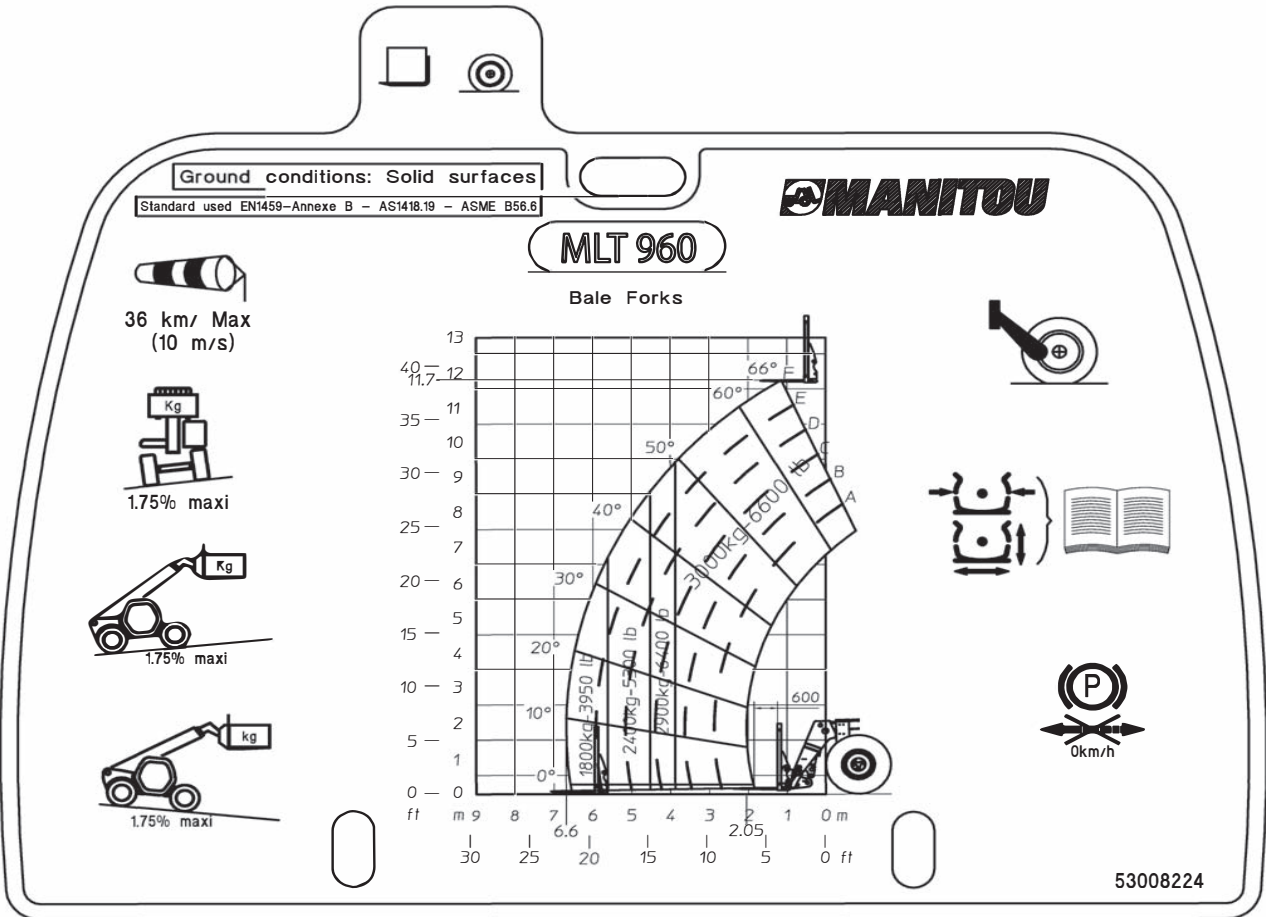



MLT 960 104JD ST4 S2

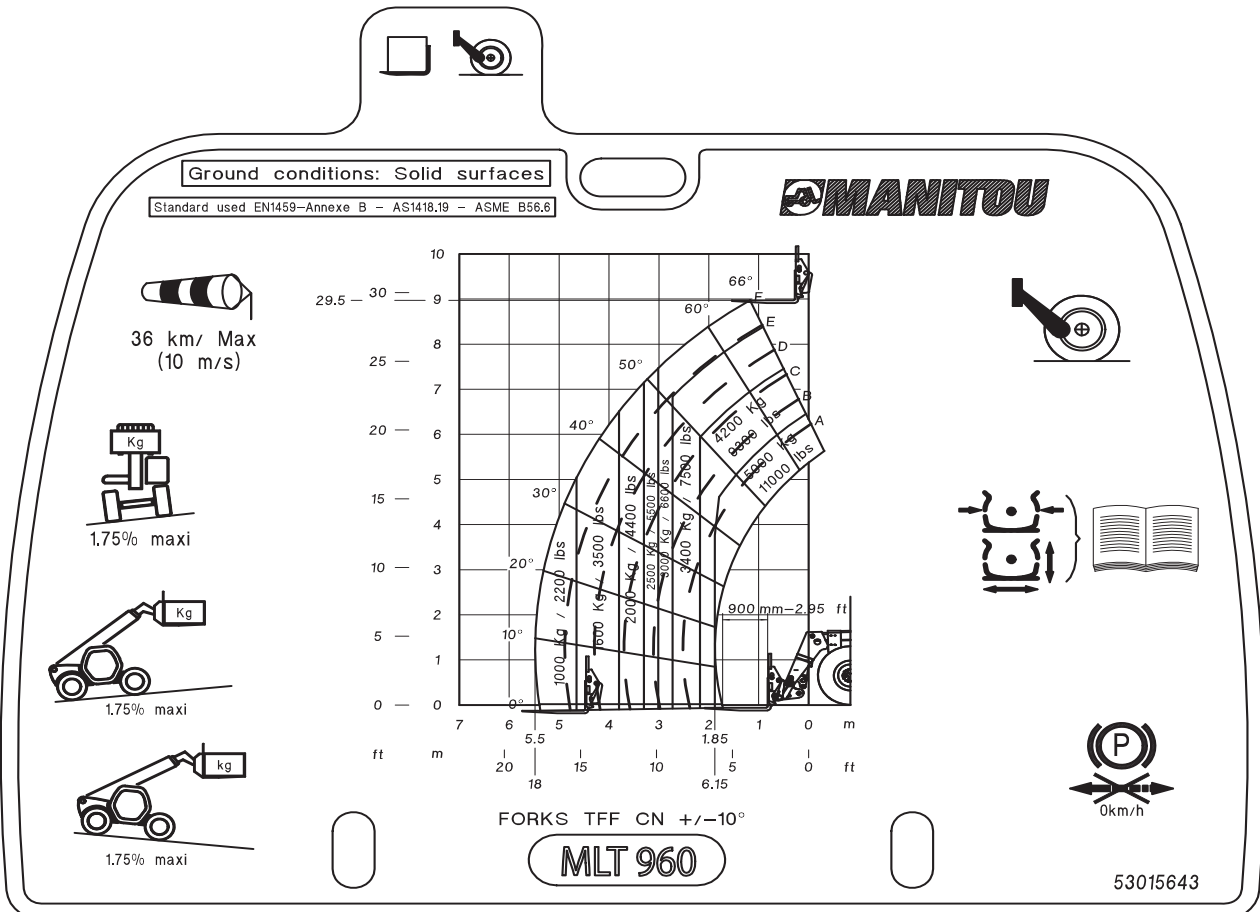
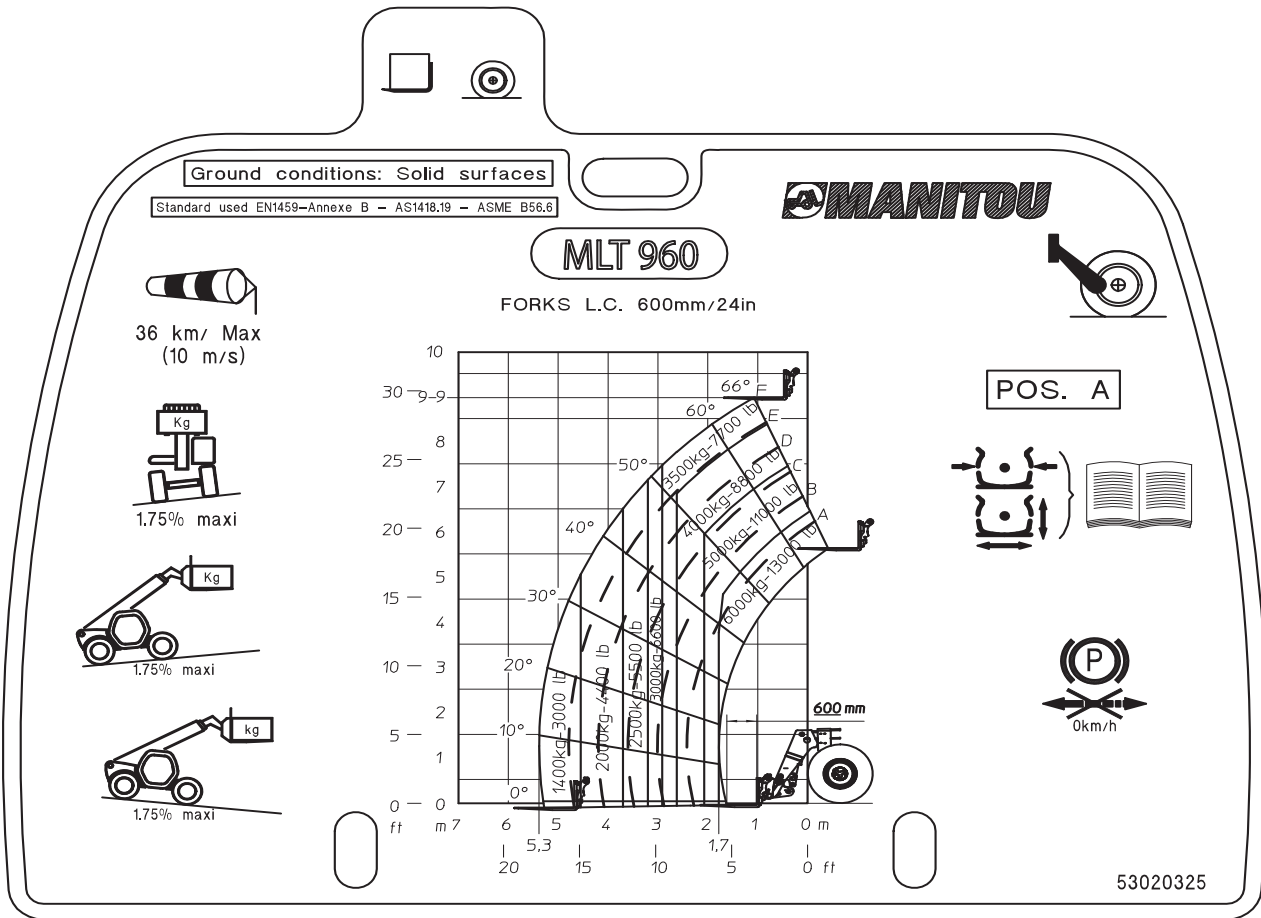



MLT 960 104JD ST4 S2

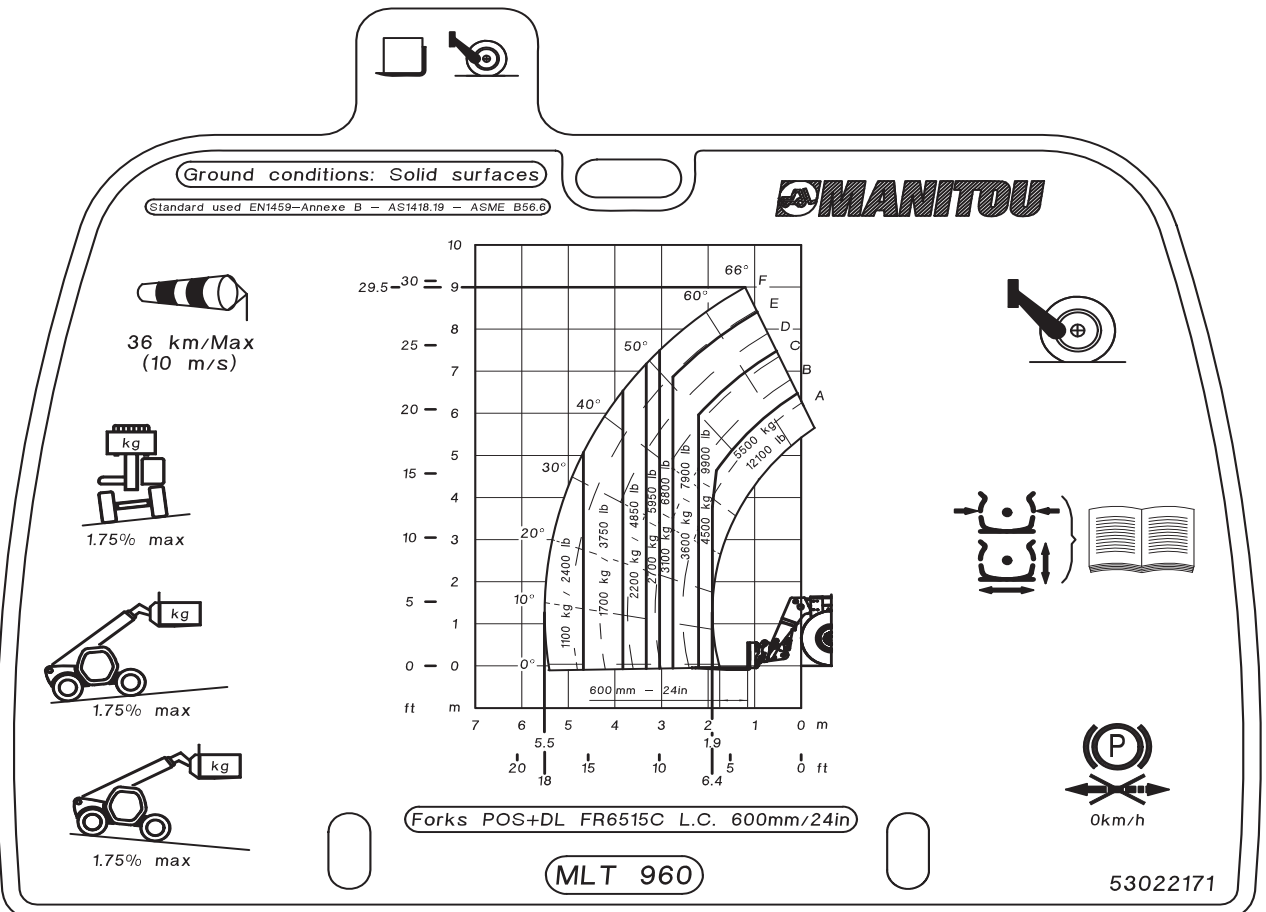
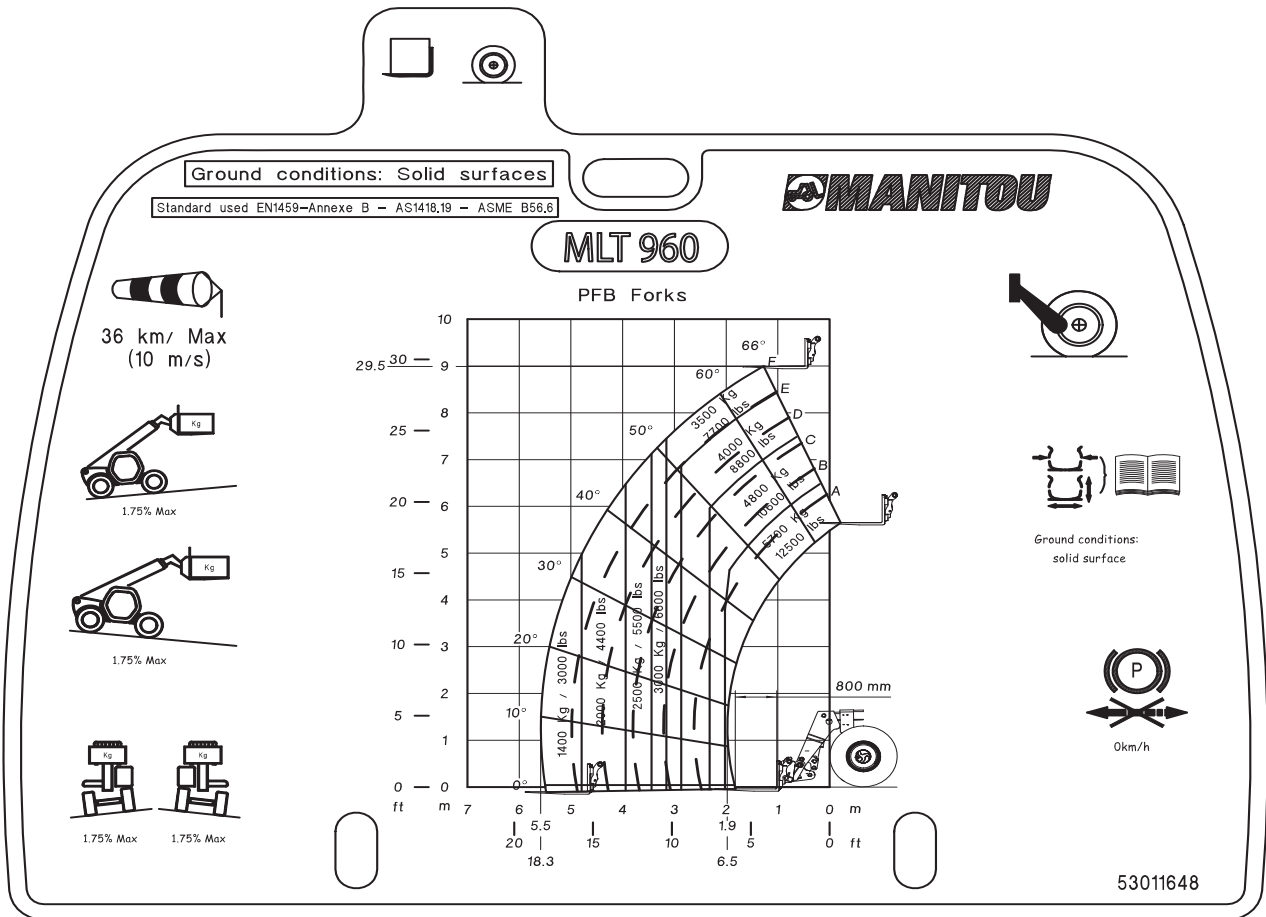



MLT 960 104JD ST4 S2

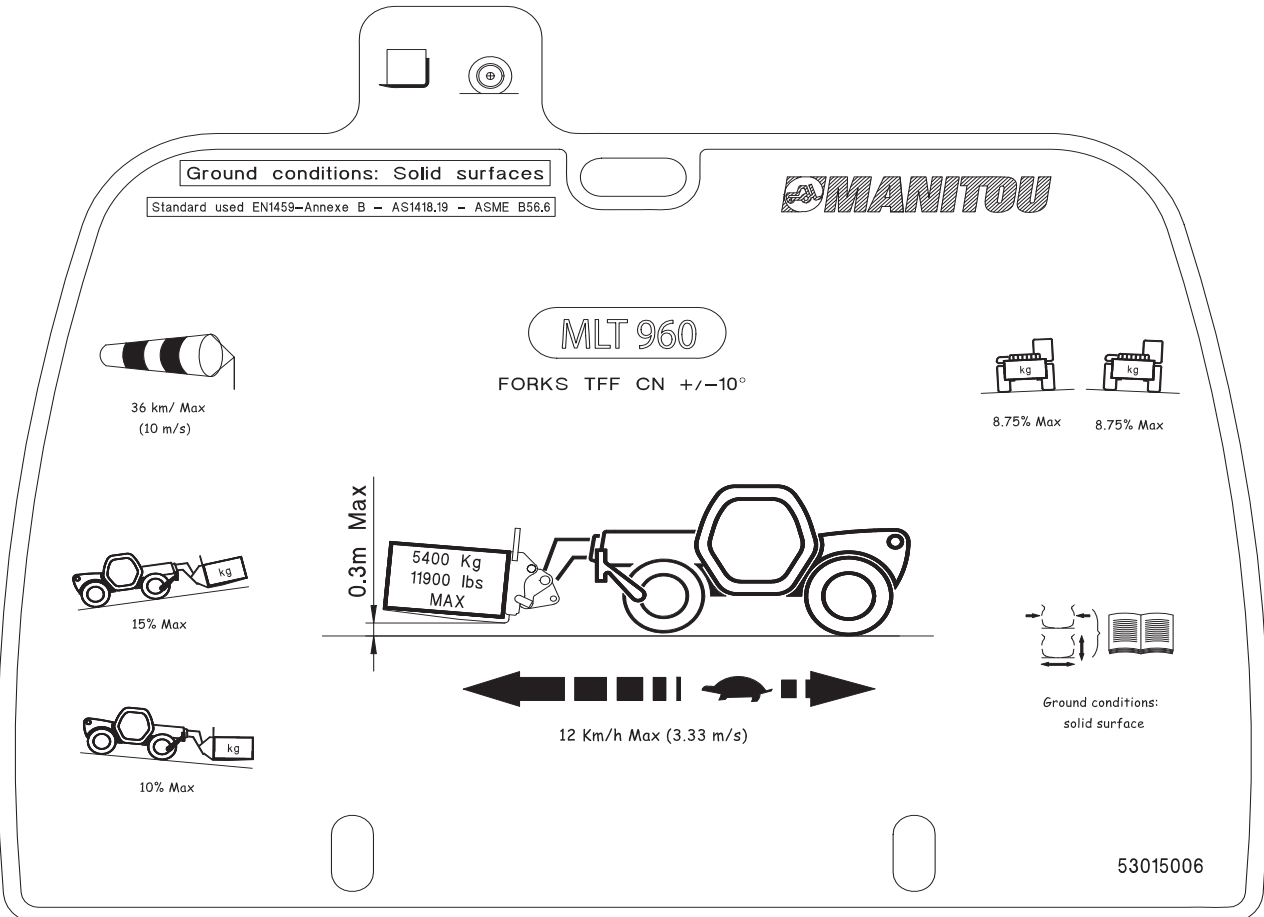
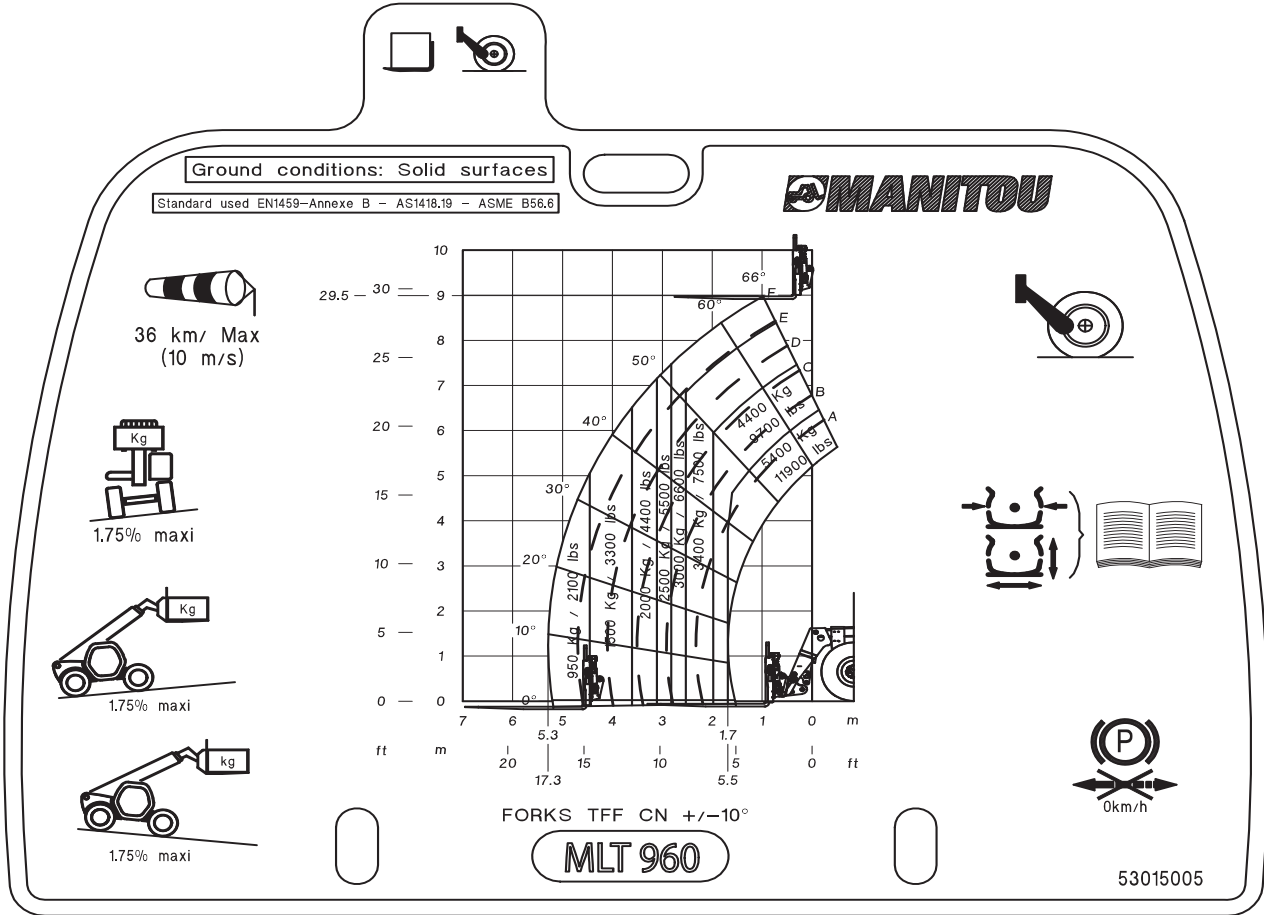



MLT 960 104JD ST4 S2

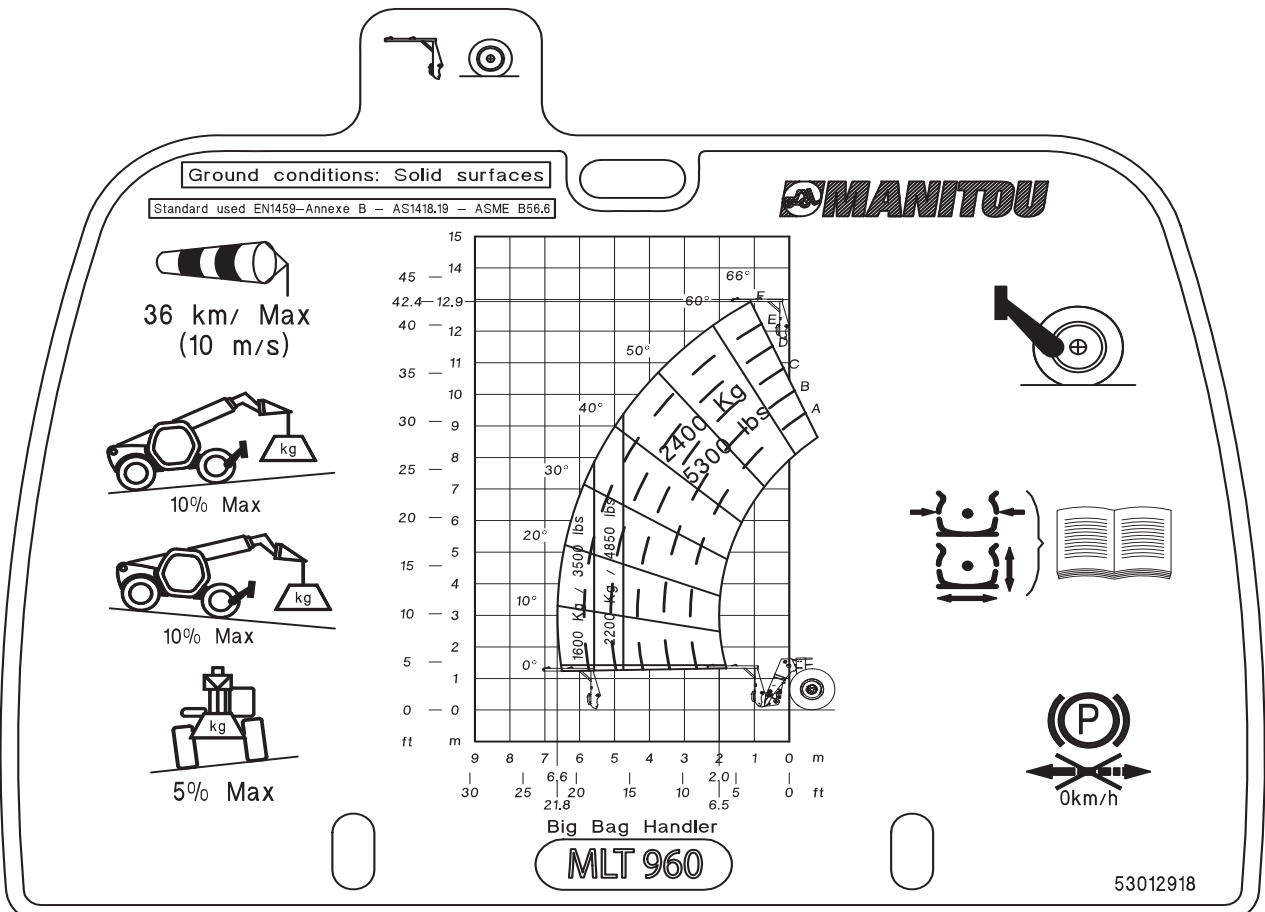
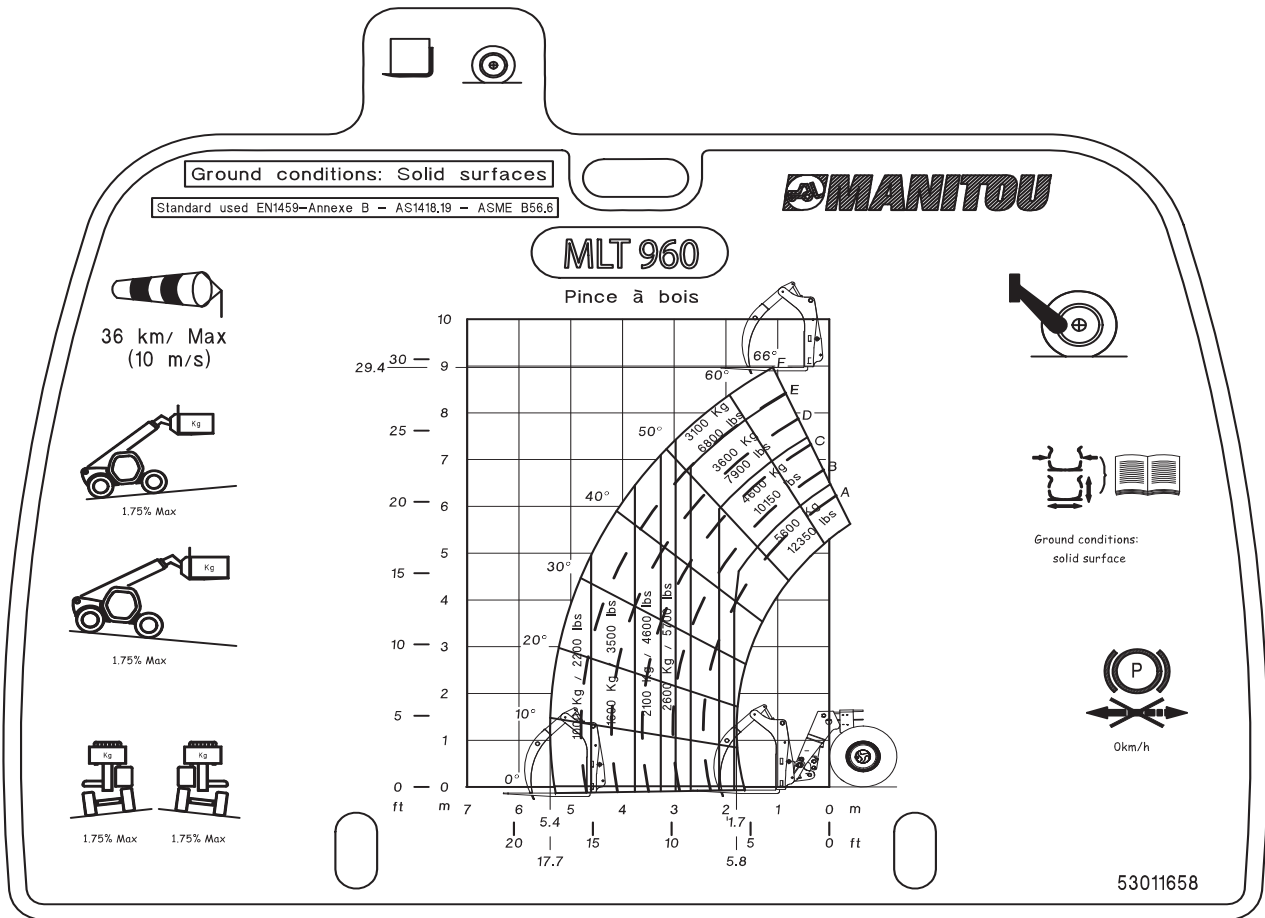



MLT 960 104JD ST4 S2

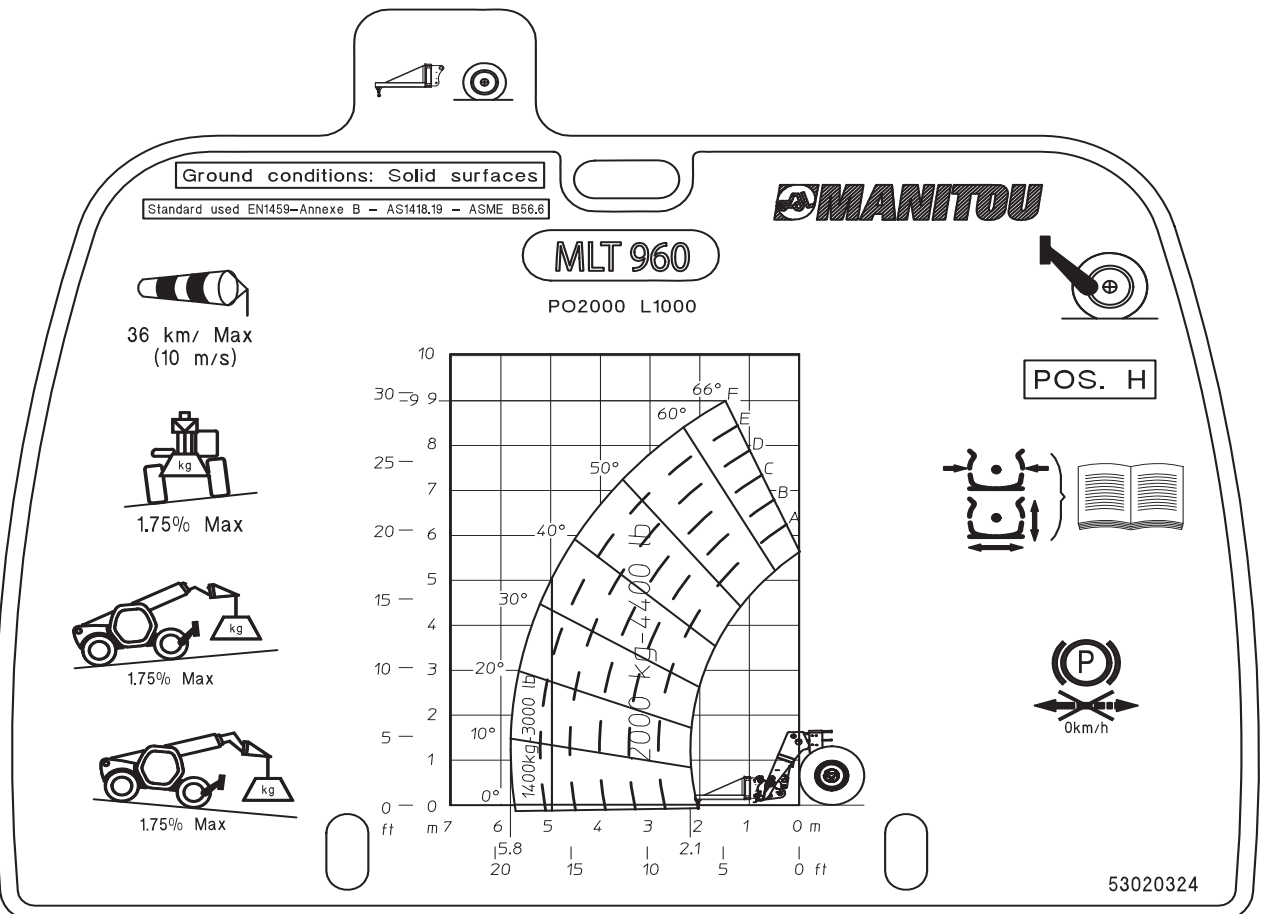
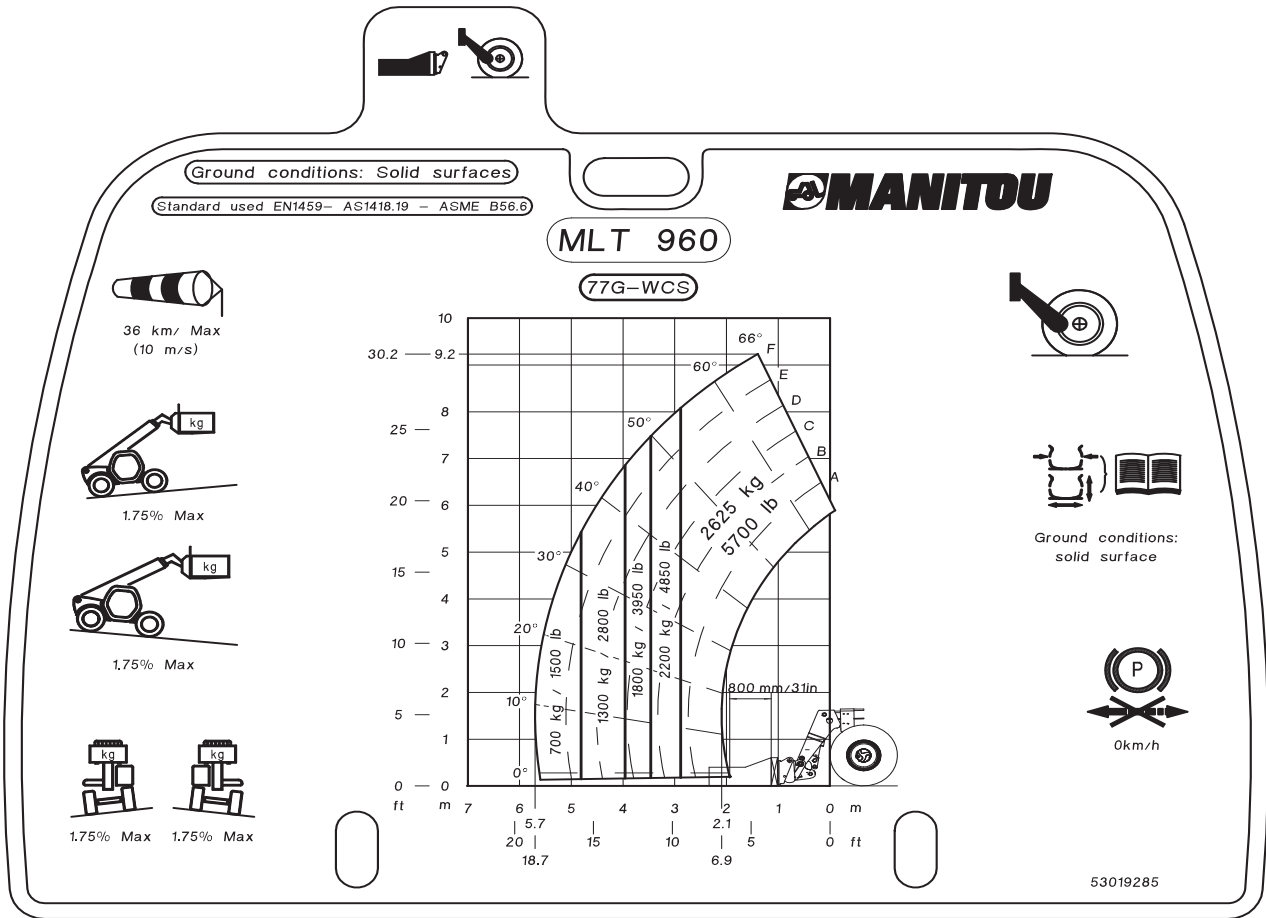



MLT 960 104JD ST4 S2

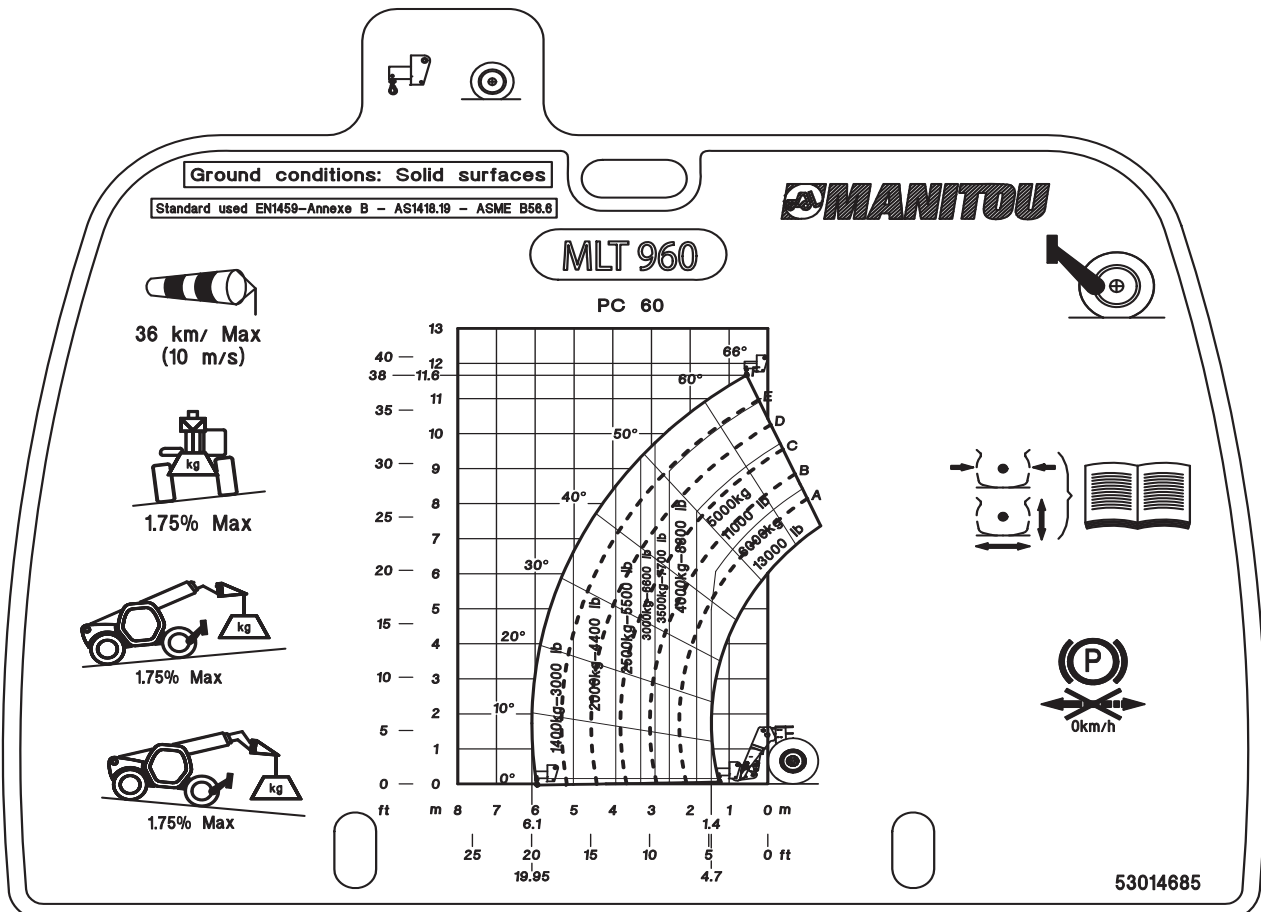
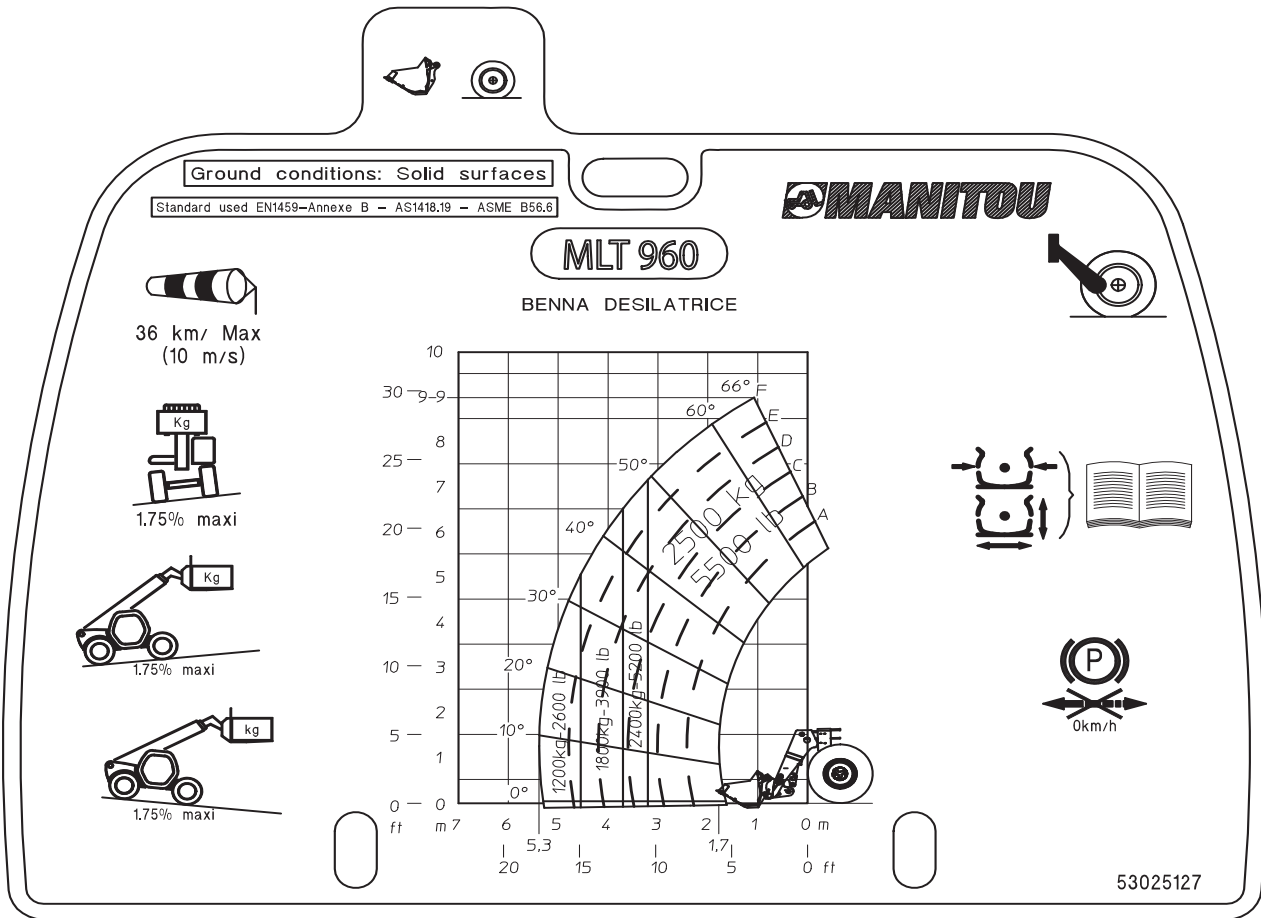

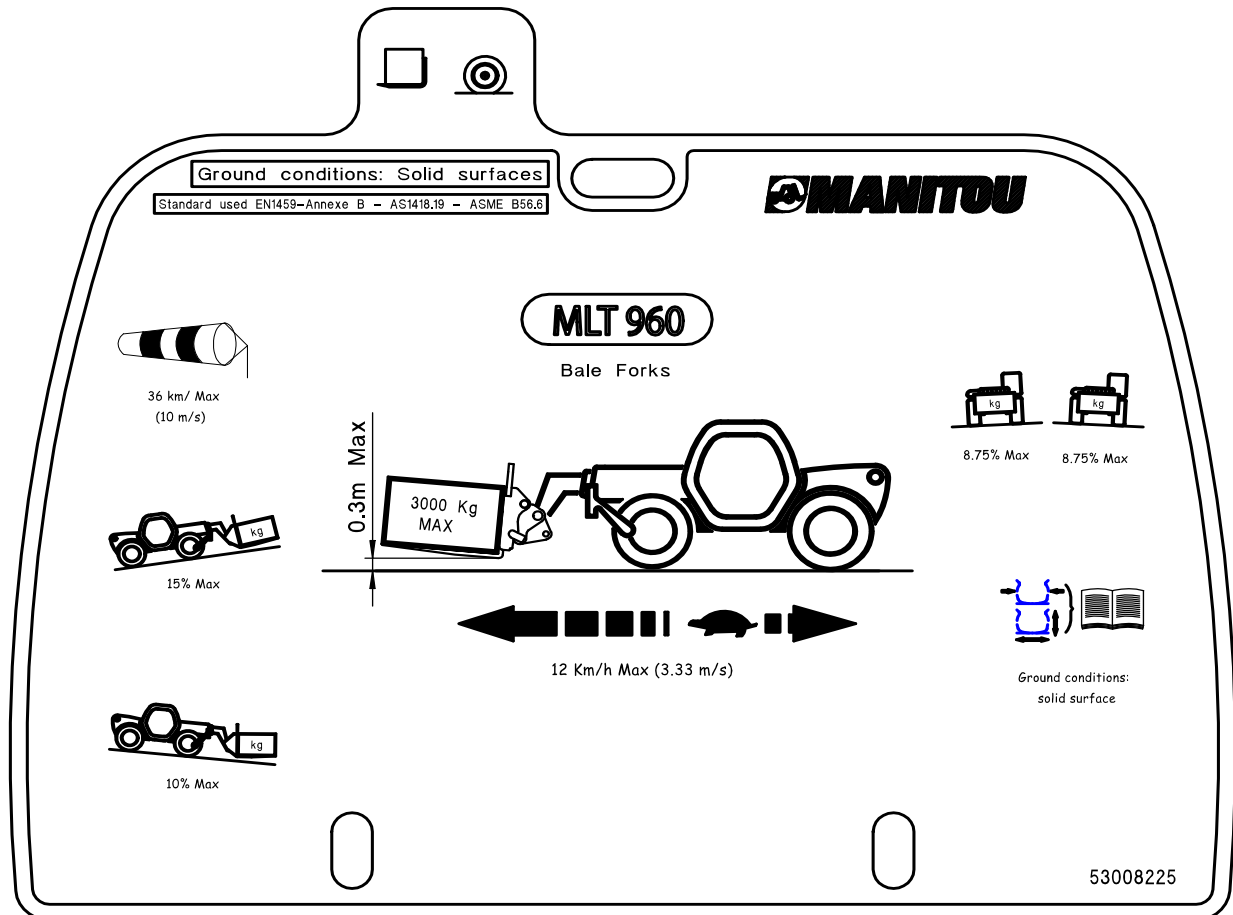
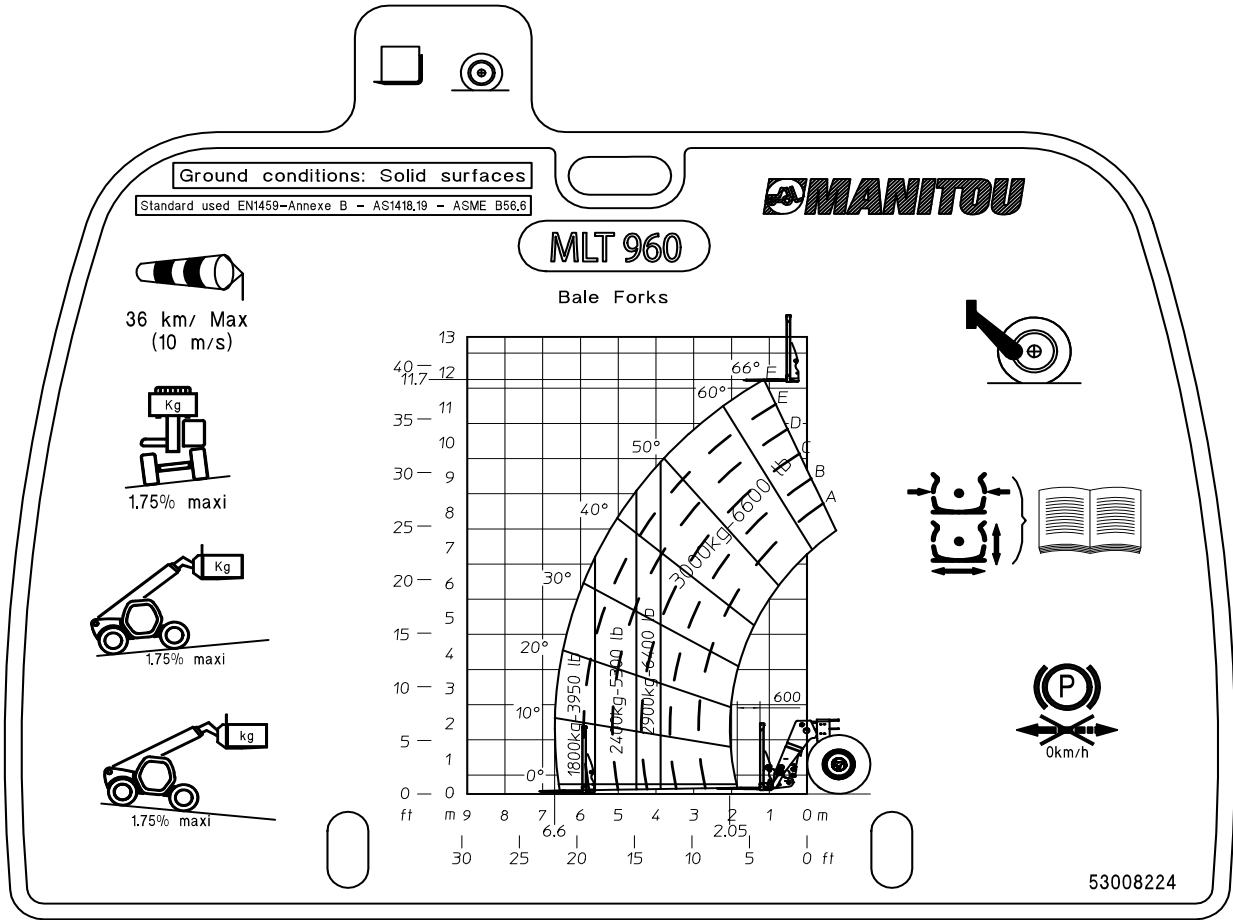

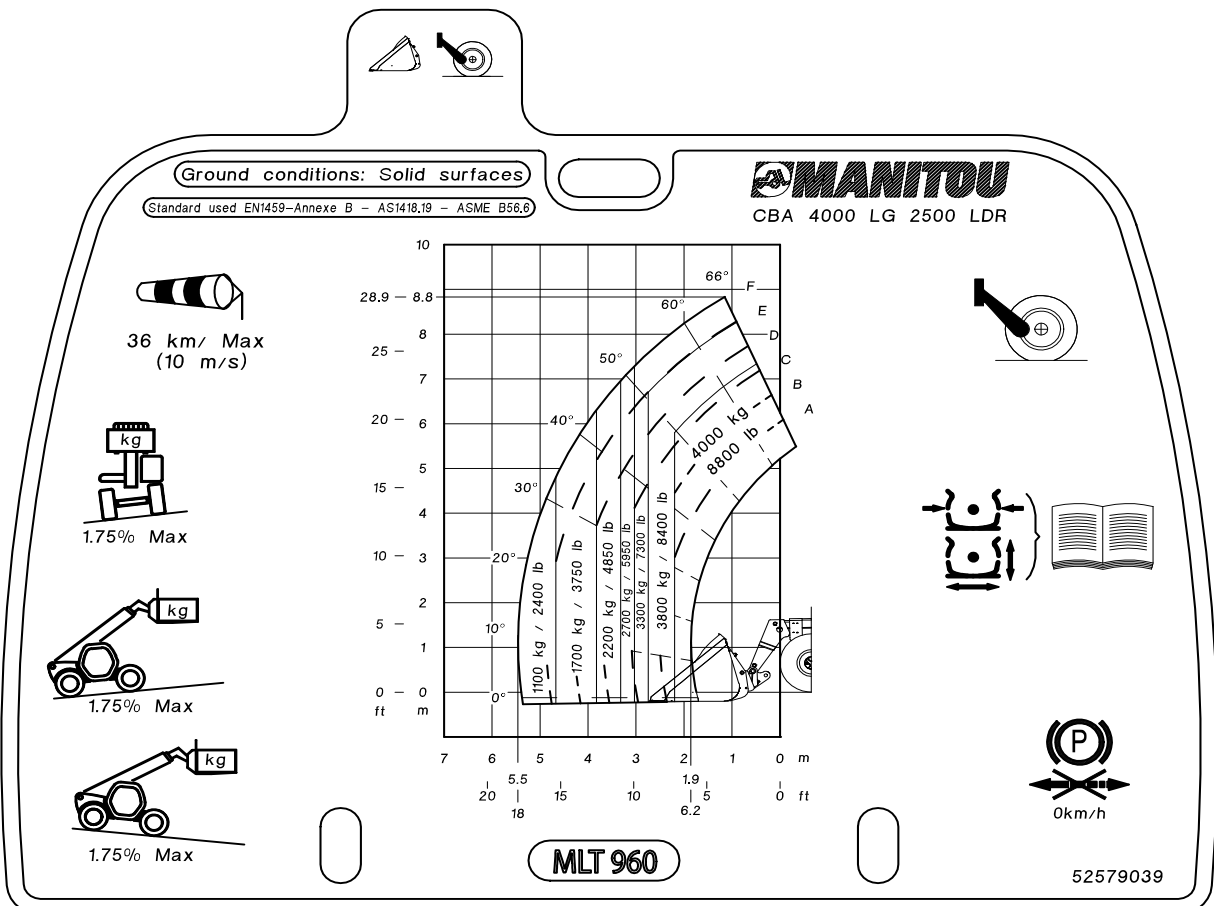
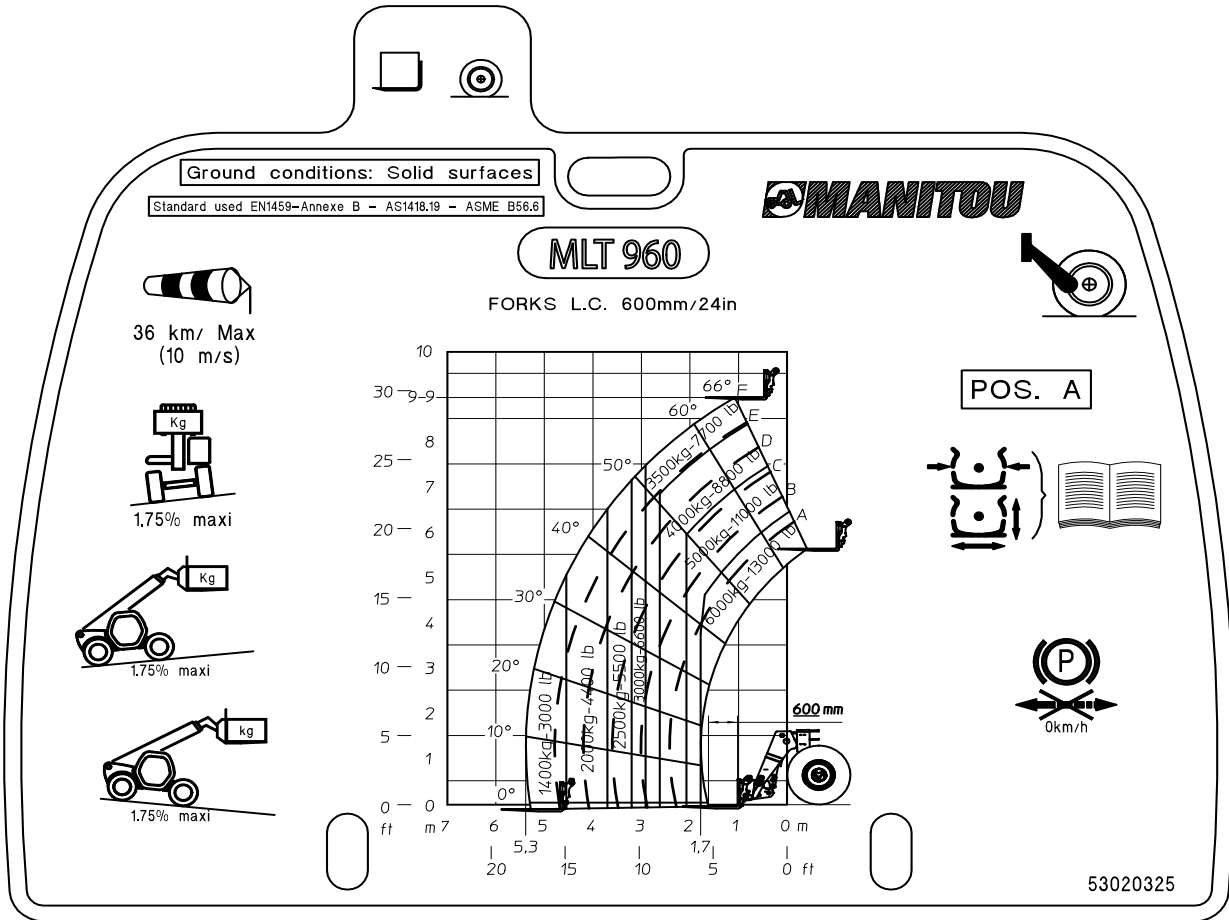

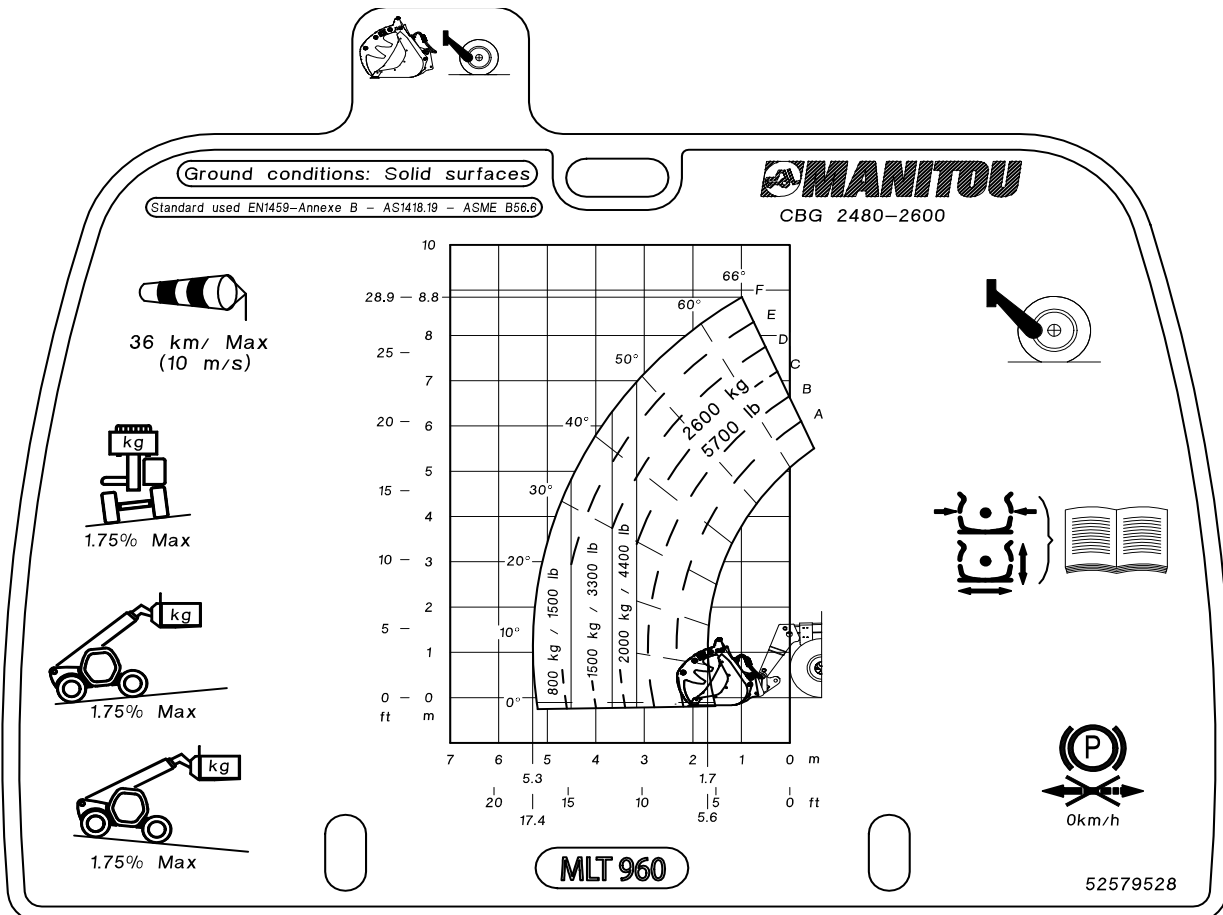
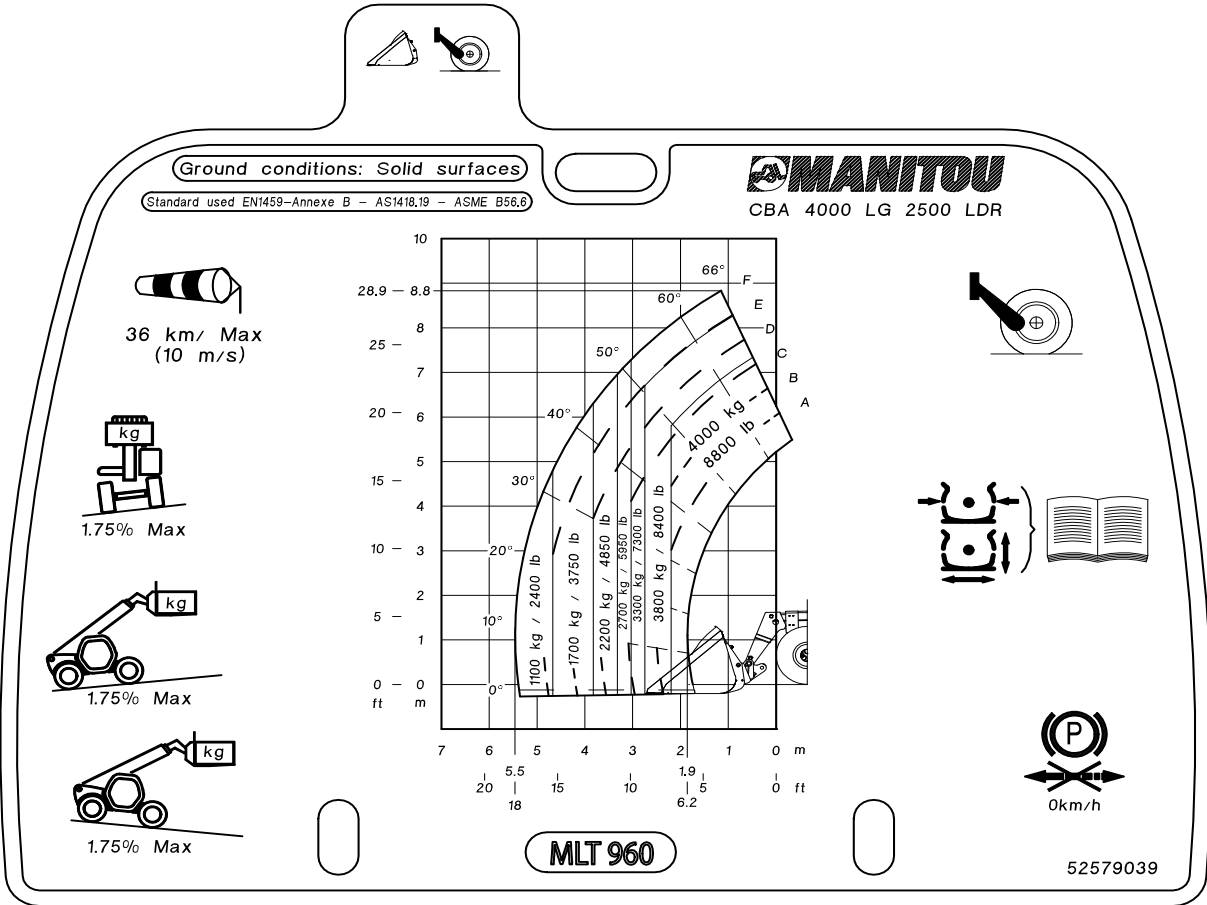

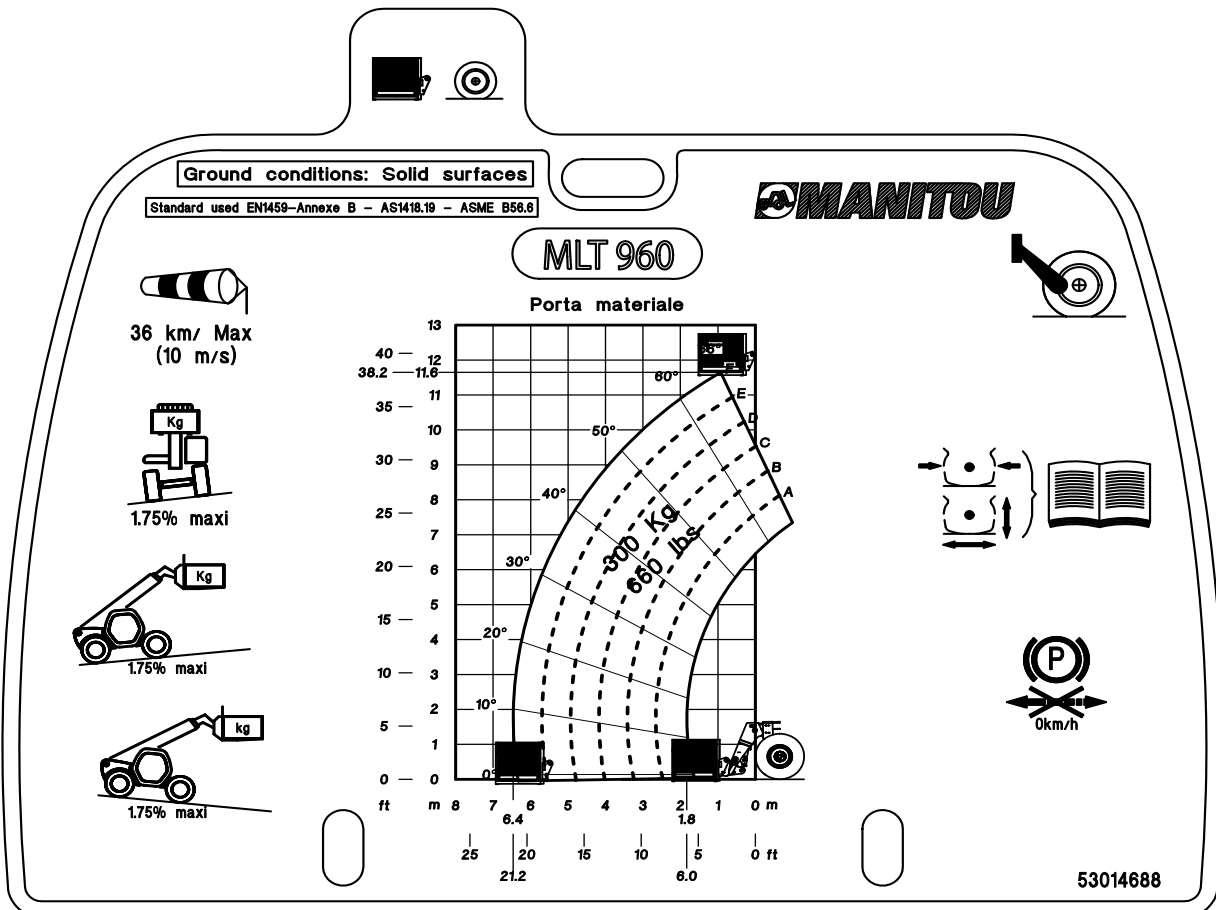
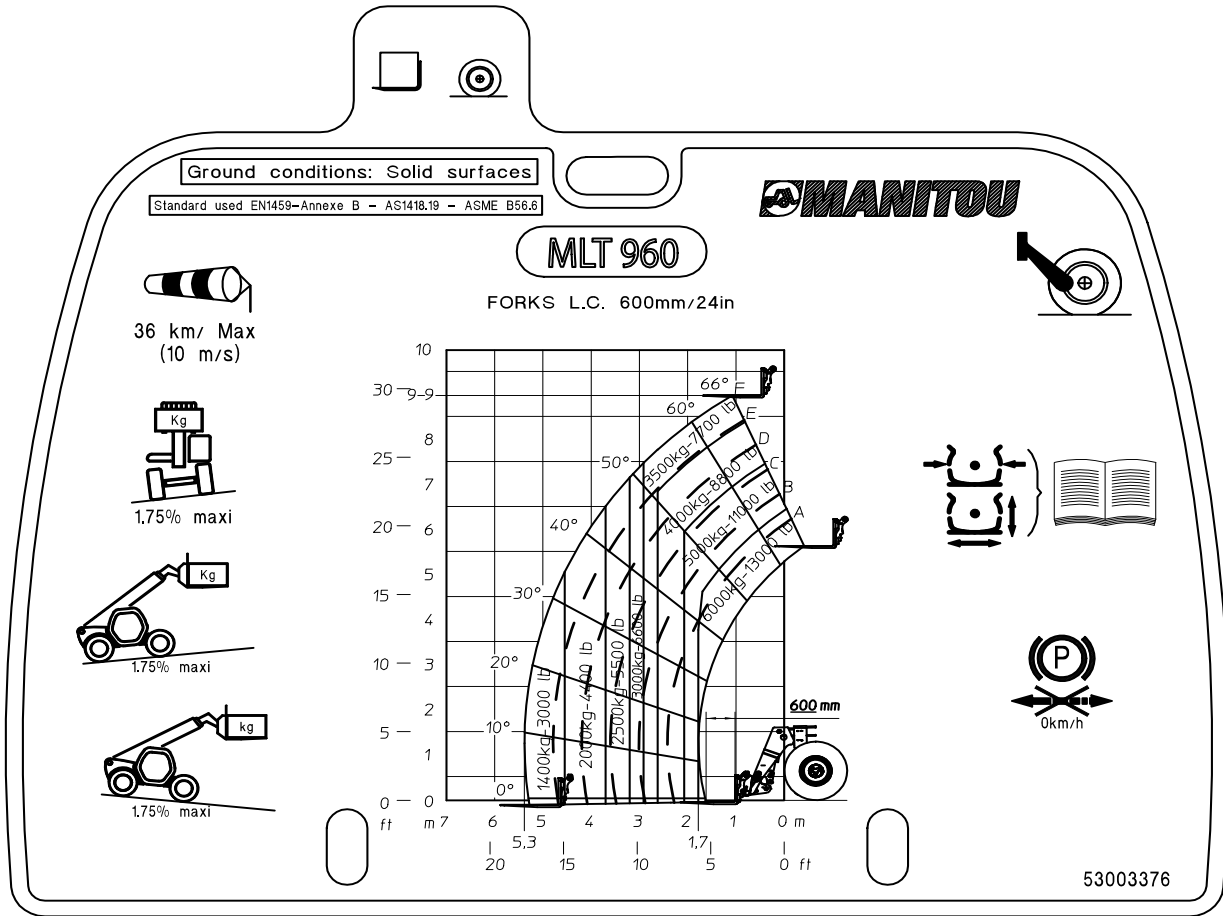

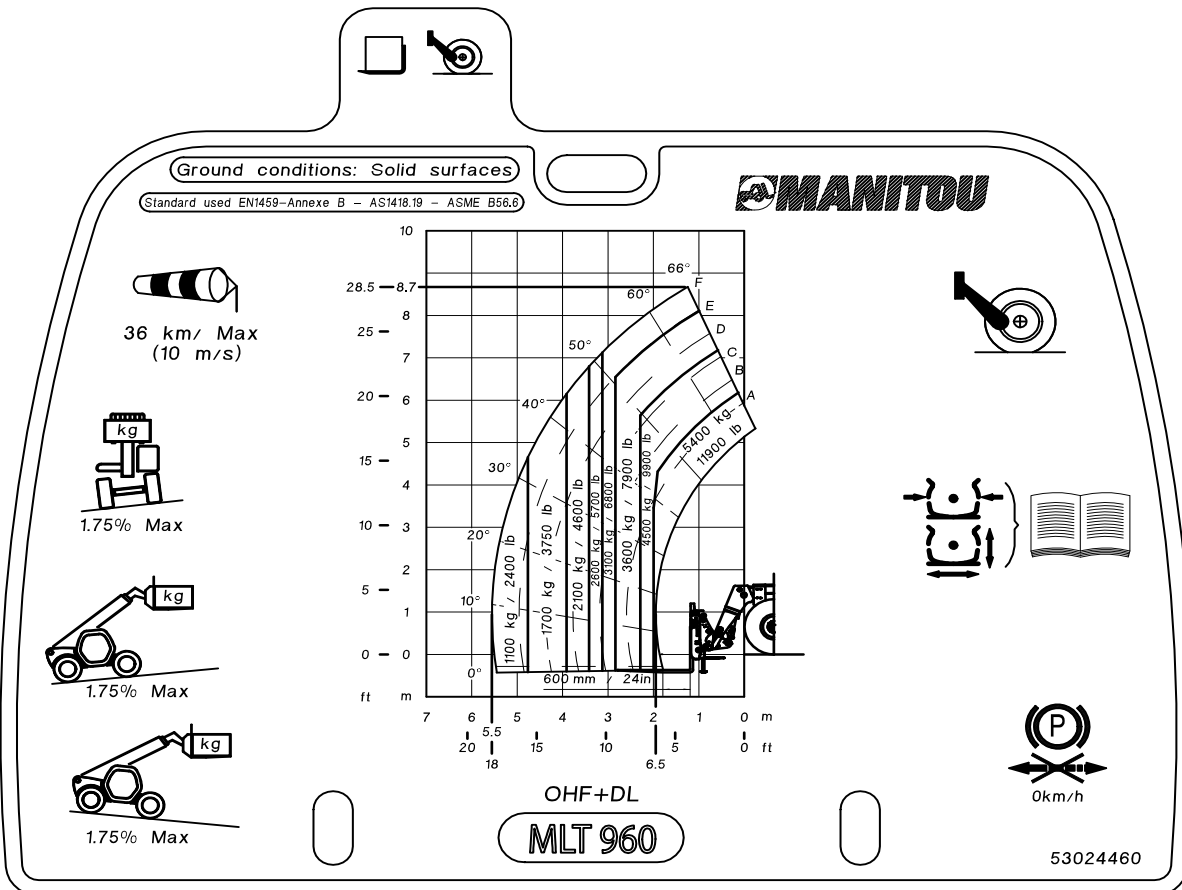
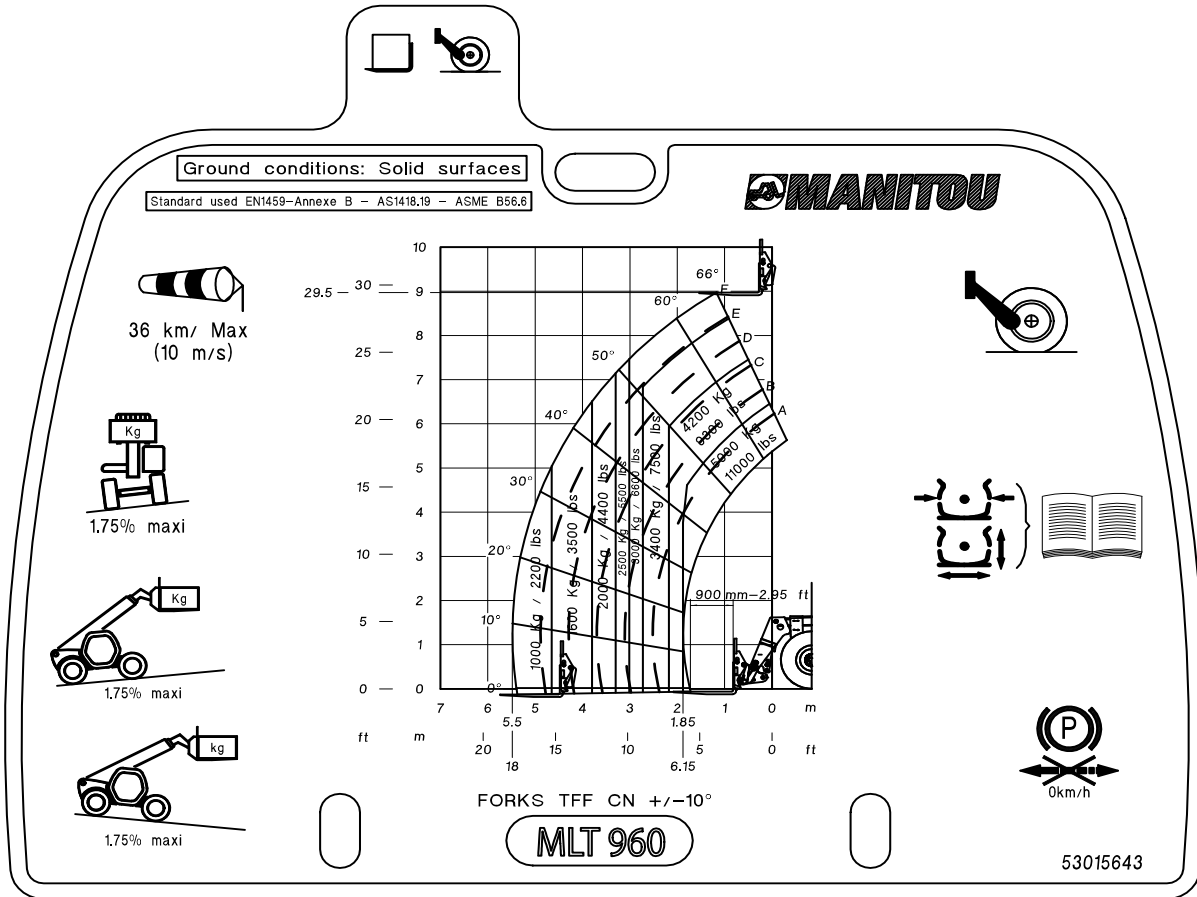

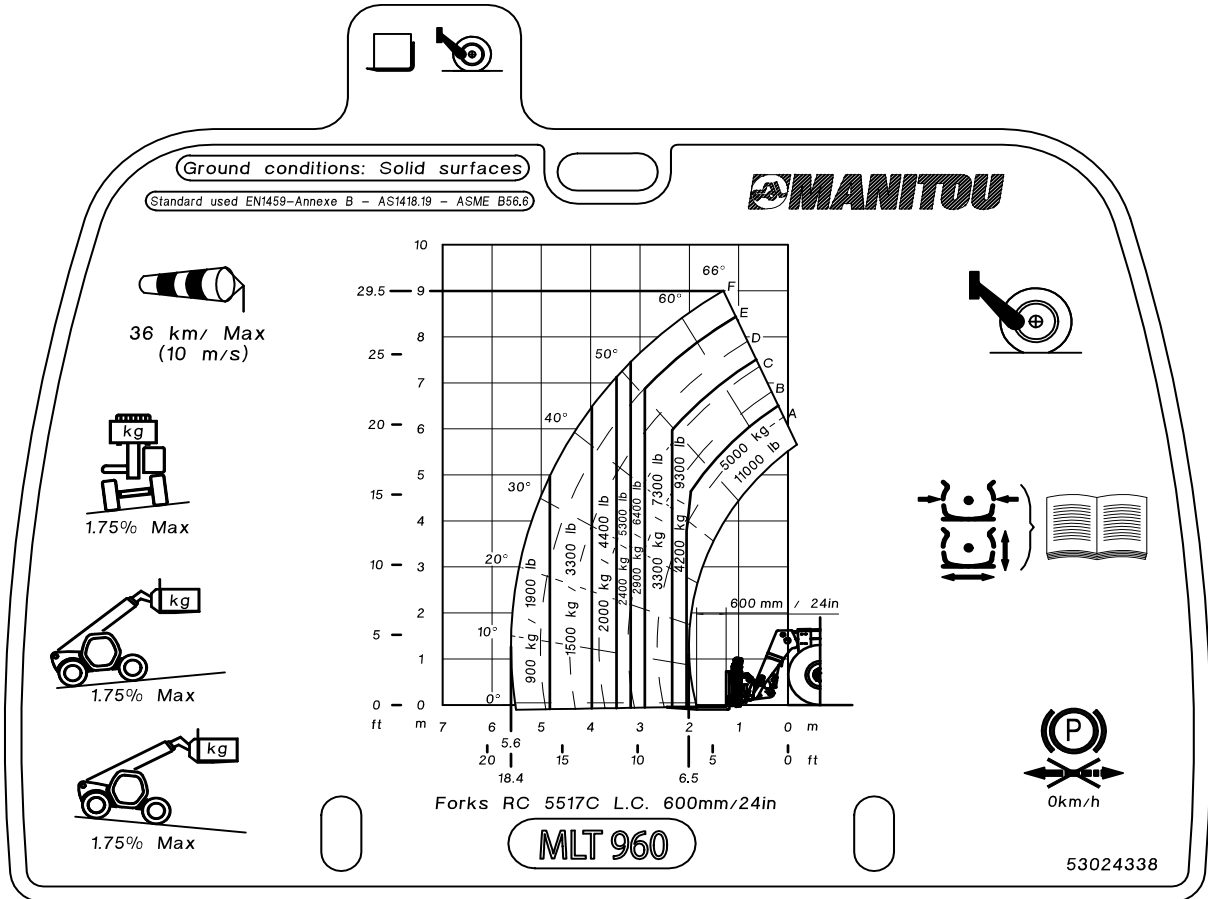



Questa pagina è intenzionalmente vuota

I DIAGRAMMI DI PORTATA SONO DISPONIBILI A RICHIESTA