



S650

Specifications

Machine Rating

Rated operating capacity	1220 kg
Tipping load	2440 kg
Pump capacity	87.1 L/min
Pump capacity (@ 91% efficiency with high flow option)	115.5 L/min
System relief at quick couplers	23.8–24.5 MPa
Max. travel speed (low range)	11.4 km/h
Max. travel speed (high range - option)	19.8 km/h

Engine

Make / Model	Kubota / V3307-DI-TE3
Fuel / Cooling	Diesel / Liquid
Power	55.4 kW
Torque, maximum at 1600 RPM (SAE J1 995 Gross)	264 Nm
Number of cylinders	4
Displacement	3331 cm ³
Fuel tank capacity	103.3 L

Weights

Operating weight	3777 kg
------------------	---------

Controls

Vehicle steering	Direction and speed controlled by two hand levers
Loader hydraulics tilt and lift	Separate foot pedals, optional Advanced Control System (ACS), Advanced Hand Control (AHC) or Selectable Joystick Control (SJC)
Front auxiliary (standard)	Electrical switch on right-hand steering lever

Drive System

Transmission	Infinitely variable tandem hydrostatic piston pumps, driving two fully reversing hydrostatic motors
--------------	---

Standard Features

High-back adjustable suspension seat	Engine/hydraulics system shutdown
Automatically activated glow plugs	Hydraulic bucket positioning
Bob-Tach™ frame	Instrumentation
Bobcat Interlock Control System (BICS)	Lift arm support
Deluxe operator cab	Work lights, front and rear
Includes interior cab foam, side, top and rear windows	Parking brake
Electrically activated proportional front auxiliary hydraulics	Seat belt
	Seat bar
	12 x 16.5, 12-ply, Heavy duty tyres
	CE certification
	Turbo-charger with approved spark arrestor

* Roll Over Protective Structure (ROPS) - meets requirements of SAE-J1040 and ISO 3471; Falling Object Protective Structure (FOPS) - meets requirements of SAE-J1043 and ISO 3449, Level I

Options

Two speed	12 x 16.5, 12-ply, Heavy duty tyres, offset rims
High flow hydraulics	12 x 16.5, 12-ply, Severe duty tyres
Deluxe instrument panel	12 x 16.5, 12-ply, Severe duty tyres, poly filled
Cab enclosure with heating	12 x 16.5, Solid flex tyres
Air conditioning	Advanced Control System (ACS)
Power Bob-Tach™	Advanced Hand Controls (AHC)
33 x 15.5-16.5, 12-ply, Superflotation tyres, offset rims	Selectable Joystick Controls (SJC)

Dimensions

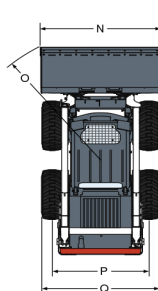
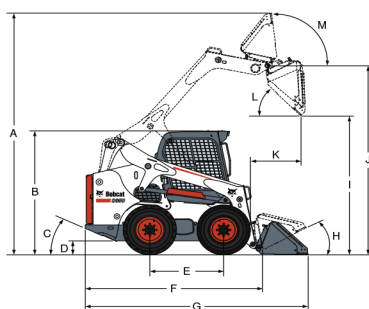

(A)	4026 mm	(J)	3149 mm
(B)	2065 mm	(K)	800 mm
(C)	25°	(L)	42.0°
(D)	406 mm	(M)	97°
(E)	1150 mm	(N)	1727 mm
(F)	2754 mm	(N)	1880 mm
(G)	3474 mm	(N)	2032 mm
(H)	30°	(O)	2106 mm
(I)	2447 mm	(P)	1507 mm
		(Q)	1832 mm



www.bobcat.eu