



S70

Specifications

Machine Rating

Rated operating capacity	343 kg
Tipping load	686 kg
Pump capacity	37 l/min @ 100% efficiency
System relief at quick couplers	207 bar
Max. travel speed	9.8 km/h

Engine

Make / Model	Kubota / D1005-E3B-BC-3
Fuel / Cooling	Diesel / Liquid
Max power @ 3000 RPM (SAE J1349)	16.8 kW
Torque at 2200 RPM (SAE J1349)	62.8 Nm
Number of cylinders	3
Displacement	1001 cm ³
Fuel tank capacity	24.6 l

Weights

Operating weight	1268 kg
------------------	---------

Controls

Vehicle steering	Direction and speed controlled by two hand levers
Loader hydraulics tilt and lift	Separate foot pedals
Front auxiliary	Lateral movement of right-hand steering lever

Drive System

Transmission	Infinitely variable tandem hydrostatic piston pumps, driving two fully reversing hydrostatic motors
--------------	---

Standard Features

Automatically activated glow plugs	Rear and top window
Bob-Tach™ frame	Seat belt
Bobcat Interlock Control System (BICS)	Seat bar
Engine / Hydraulic system shutdown	Spark arrestor muffler
Front auxiliary hydraulics	CE certification
High-back cushion suspension seat	
Instrumentation	
Lift arm support	
23 x 5.70-12, 4-ply, Narrow tyres	
Operating lights, front and rear	
Operator cab	
Parking brake	

* Roll Over Protective Structure (ROPS) – meets requirements of SAE-J1040 and ISO 3471

Attachments

- Buckets
- Pallet fork

Dimensions

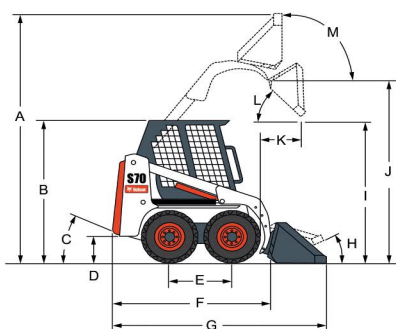

(A)	3131 mm	(J)	2399 mm
(B)	1814 mm	(K)	469 mm
(C)	25°	(L)	34°
(D)	141 mm	(M)	97°
(E)	722 mm	(N)	914 mm
(F)	1917 mm	(O)	1557 mm
(G)	2553 mm	(P)	752 mm
(H)	22°	(Q)	901 mm
(I)	1891 mm		

