



YANMAR

MIDI-EXCAVATOR

ViO80-1

8065 / 8125 kg



ViO80-1



> **EQUIPMENT**

> **STANDARD EQUIPMENT**

Engine

- 4TNV98C-WBV Yanmar diesel
- Meets Phase IIIB and Tier 4 standards
- Direct Injection
- Common Rail System
- EGR Electrical Control System
- Engine Control Unit (ECU)
- Particle filter with automatic regeneration (without additives)
- Water Separator
- Eco Mode
- Auto-Idle System (auto deceleration)
- Throttle using potentiometer

+

Hydraulic system

- VIPPS Hydraulic system (ViO progressive 3 pump system)
- 2 auxiliary circuits with adjustable proportional control by potentiometer
- Electronic regulation of hydraulic pumps
- Automatic 2nd speed
- Filter on steering hydraulic circuit
- External hydraulic oil gauge

+

Cabin

- LCD Interface
- Cabin mounted on viscoelastic silent blocks
- Air conditioning
- Adjustable and reclining seat with

- fabric covers, air suspension and headrest
- Adjustable wrist support
- Foot rests
- Wide travel pedals
- Windshield with 2 fully retractable parts
- Sliding double right side window
- Transparent upper front part
- Visor
- Wipers
- Windshield washer
- Automatic ceiling lamp
- Radio with USB port
- 2 x 12V outlets
- Storage Boxes
- Secure document storage
- Cup Holder

+

Undercarriage

- Asymmetric VICTAS tracks
- Blade cylinder supply hose into two parts

+

Safety

- Handrails
- Safety lever
- Seat belt with retractor
- Evacuation hammer
- Anchor points
- 5 mirrors
- Horn
- Travel beep

Lighting

- 1 LED light integrated into the boom
- 2 LED lamps on the front of the cab

+

Miscellaneous

- Electric refuelling pump with automatic stop
- Fuel gauge
- Double axis position of the arm cylinder
- Protection of the blade and boom cylinders
- Hoses protected by abrasion-resistant sleeves.
- Cataphoresis treated steel parts
- Locking Covers
- Toolbox
- Toolkit
- Grease pump

OPTIONAL EQUIPMENT

Special paint | Safety valves for lifting + overload warning | Long arm | Additional counterweight (+400 kg) | Prolongation of the auxiliary circuits to arm end | Quick couplings | Anti-theft (key/keyboard) | GPS Tracking | Centralised greasing | Skai seat | LED rear light + flashing light | FOPSII protection grid

ACCESSORIES

Yanmar gives you the accessories that fit your needs and match the safety standards in force in your country: mechanical quick coupler, hydraulic quick coupler, ditching bucket, swinging bucket, backhoe bucket, hydraulic hammer...

ViO80-1



DIMENSIONS <

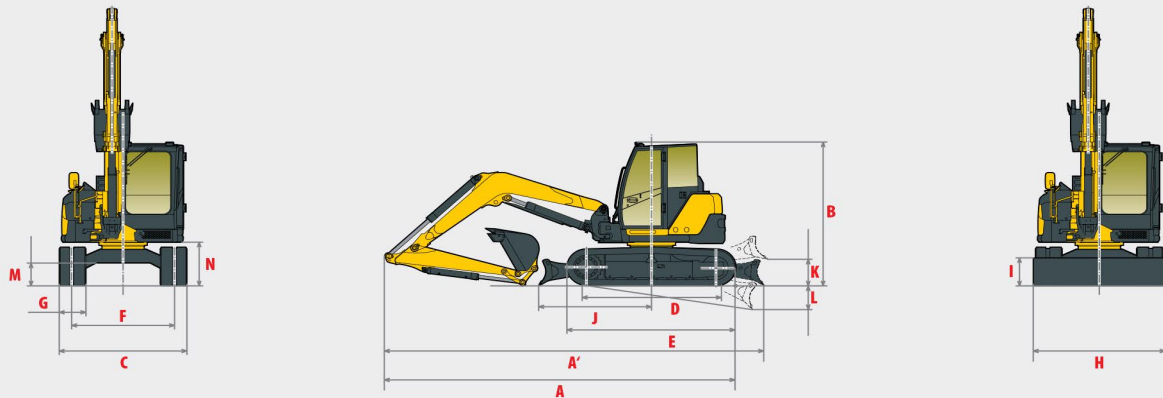

A » Overall length	6410 / 6450* mm	H » Overall blade width	2260 mm
A' » Overall length with blade at the back	6920 / 6960* mm	I » Overall blade height	450 mm
B » Overall height	2710 mm	J » Blade distance	2030 mm
C » Overall width	2270 mm	K » Max. lifting height above the ground	460 mm
D » Length of track on ground	2290 mm	L » Max. lowering depth from the ground	480 mm
E » Undercarriage length	2890 mm	M » Minimum ground clearance	380 mm
F » Lane	1870 mm	N » Ground clearance under counterweight	700 mm
G » Track width	450 mm		

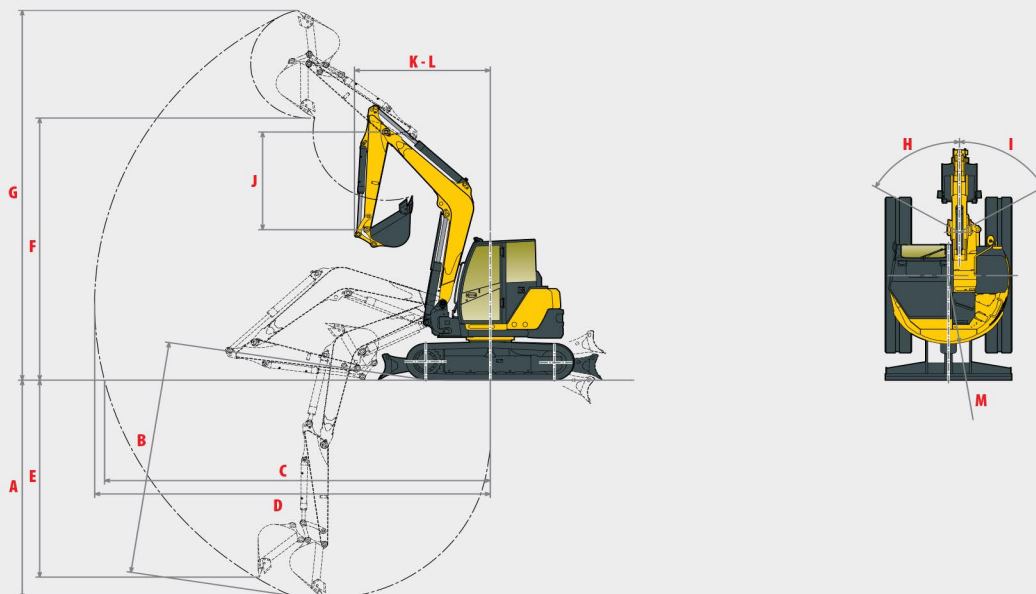

A » Max. digging depth - Blade lifted	4130 / 4500* mm	H » Boom swinging base to left	57°
B » Max. digging depth - Blade lowered	4430 / 4790* mm	I » Boom swinging base to right	60°
C » Max. digging reach on ground	6820 / 7160* mm	J » Arm length	1650 / 2000* mm
D » Max. digging reach	6960 / 7290* mm	K » Front boom swing	2470 / 2520* mm
E » Max vertical wall	3780 / 4130* mm	L » Front turning radius with boom swing	2130 / 2170* mm
F » Max. unloading height	4700 / 4950* mm	M » Rear boom swing	1135 mm
G » Max. cutting height	6810 / 7020* mm	M' » Rear boom swing with additional counterweight	1265 mm

*Long arm

Subject to technical modifications. Dimensions in mm with specific Yanmar bucket.



ViO80-1



> **LIFTING FORCE**



Tipping load,
rating over front



Tipping load,
rating over side 90°

Standard counterweight, standard arm																	
With tiltrotator*									Without tiltrotator								
Blade on ground		Blade above ground						Blade on ground		Blade above ground							
A	Max	5 m		4 m		3 m		Max	5 m		4 m		3 m				
B																	
5 m	-	-	-	-	-	-	-	1730	1720	1750	1740	-	-	1740	1750	1720	1720
4 m	-	-	976	1432	1036	1522	1532	1100	1090	1680	1150	1190	1190	1680	1250	1770	1780
3 m	746	1442	996	976	1532	1036	1522	1832	1502	-	-	-	-	-	-	-	-
2 m	666	736	1412	796	996	986	1532	1036	1522	1506	1832	1812	-	-	-	-	-
1 m	656	656	1432	706	976	976	1672	1046	1526	1516	2232	1626	-	-	-	-	-
0 m	696	646	1462	686	896	926	1882	946	-	-	-	-	-	-	-	-	-
-1 m	776	756	1442	806	-	-	-	-	-	-	-	-	-	-	-	-	-
-2 m	-	-	-	-	-	-	-	-	-	-	-	-	-	-	-	-	-
-3 m	-	-	-	-	-	-	-	-	-	-	-	-	-	-	-	-	-

C

¹ Rototilt of 285 kg

The data in this table represents the lifting capacity in accordance with ISO 10567. They do not include the weight of the bucket and correspond to 75% of the maximum static tipping load or 87% of the hydraulic lifting capacity. Data marked with * are the hydraulic limits of the lifting force.

ViO80-1



SPECIFICATIONS <

| WEIGHT +/- 2% (CE STANDARDS)

	Weight	Ground pressure
Operating weight (rubber tracks)	8,065 kg	0.358 kg/cm ²
Transport weight (rubber tracks)	7,990 kg	0.358 kg/cm ²
With steel tracks	+ 60 kg	0.360 kg/cm ²
Additional counterweight	+ 400 kg	0.4 kg/cm ²
With FOPS II protection	+ 100 kg	0.362 kg/cm ²

| ENGINE

Type	4TNV98C-WBV
Fuel	Diesel
Net Power	40.7 kilowatts / 55.3 hp / 2,000 rpm
Gross Power	42.2 kilowatts / 57.3 hp / 2,000 rpm
Displacement	3,318 cm ³
Maximum torque	241 Nm / 1300 rpm
Cooling	Liquid
Starter	3 kW
Battery	12 V – 92 Ah
Alternator	12 V – 80 A

| HYDRAULIC SYSTEM

Maximum pressure	255 bar
1 double piston pump with variable flow	2 x 70.3 l/min
1 piston pump with variable flow	53.2 l/min
1 gear pump	19 l/min

PTO	Theoretical data at 1900 rpm	
	Pressure	Oil flow
	0 ~ 240 bar	120 ~ 32 l/min
	0 ~ 240 bar	120 ~ 32 l/min



Oil flow decreases as the pressure increases

| PERFORMANCE

Travel speed	2.5 / 4.5 km/h (2.3 / 4.1 km/h with steel tracks)
Rotation speed	9 rpm
Digging force (arm)	40,8 kN (4,160 kgf) / 35,9 kN (3,360 kgf) with long arm
Digging force (bucket)	63.5 kN (6,480 kgf)
Traction force	61 kN
Grade ability	30°
Noise level (2000/14/CE & 2005/88/CE)	73 dB(A) / 98dB(A) (LwA)

| UNDERCARRIAGE

Number of top rollers	1
Number of bottom rollers	5
Track tensioning system	Using grease pump

| CAPACITIES

Fuel tank	115 l
Coolant	9.3 l
Engine oil	11.2 l
Hydraulic circuit	112 l
Hydraulic tank	60 l

MAINTENANCE FREQUENCY

Change engine oil and filter: **250 hours** | Change fuel filter: **500 hours** | Change hydraulic oil filter: **1,000 hours** |
 Change hydraulic oil filter: **1,000 hours** | Change cooling fluid: **1,000 hours** | Clean particulate filter: **3,000 hours** |
 Change particle filter: **9,000 hours**